



**Mitsubishi Industrial Robot**

**CR750-D/CR751-D Controller**

**RH-3FH-D Series**

**Standard Specifications Manual**

---



## Safety Precautions

Always read the following precautions and the separate "Safety Manual" before starting use of the robot to learn the required measures to be taken.

-  **CAUTION** All teaching work must be carried out by an operator who has received special training. (This also applies to maintenance work with the power source turned ON.)  
Enforcement of safety training
-  **CAUTION** For teaching work, prepare a work plan related to the methods and procedures of operating the robot, and to the measures to be taken when an error occurs or when restarting. Carry out work following this plan. (This also applies to maintenance work with the power source turned ON.)  
Preparation of work plan
-  **WARNING** Prepare a device that allows operation to be stopped immediately during teaching work. (This also applies to maintenance work with the power source turned ON.)  
Setting of emergency stop switch
-  **CAUTION** During teaching work, place a sign indicating that teaching work is in progress on the start switch, etc. (This also applies to maintenance work with the power source turned ON.)  
Indication of teaching work in progress
-  **DANGER** Provide a fence or enclosure during operation to prevent contact of the operator and robot.  
Installation of safety fence
-  **CAUTION** Establish a set signaling method to the related operators for starting work, and follow this method.  
Signaling of operation start
-  **CAUTION** As a principle turn the power OFF during maintenance work. Place a sign indicating that maintenance work is in progress on the start switch, etc.  
Indication of maintenance work in progress
-  **CAUTION** Before starting work, inspect the robot, emergency stop switch and other related devices, etc., and confirm that there are no errors.  
Inspection before starting work

The points of the precautions given in the separate "Safety Manual" are given below. Refer to the actual "Safety Manual" for details.

- ⚠ DANGER** When automatic operation of the robot is performed using multiple control devices (GOT, programmable controller, push-button switch), the interlocking of operation rights of the devices, etc. must be designed by the customer.
- ⚠ CAUTION** Use the robot within the environment given in the specifications. Failure to do so could lead to a drop or reliability or faults. (Temperature, humidity, atmosphere, noise environment, etc.)
- ⚠ CAUTION** Transport the robot with the designated transportation posture. Transporting the robot in a non-designated posture could lead to personal injuries or faults from dropping.
- ⚠ CAUTION** Always use the robot installed on a secure table. Use in an instable posture could lead to positional deviation and vibration.
- ⚠ CAUTION** Wire the cable as far away from noise sources as possible. If placed near a noise source, positional deviation or malfunction could occur.
- ⚠ CAUTION** Do not apply excessive force on the connector or excessively bend the cable. Failure to observe this could lead to contact defects or wire breakage.
- ⚠ CAUTION** Make sure that the workpiece weight, including the hand, does not exceed the rated load or tolerable torque. Exceeding these values could lead to alarms or faults.
- ⚠ WARNING** Securely install the hand and tool, and securely grasp the workpiece. Failure to observe this could lead to personal injuries or damage if the object comes off or flies off during operation.
- ⚠ WARNING** Securely ground the robot and controller. Failure to observe this could lead to malfunctioning by noise or to electric shock accidents.
- ⚠ CAUTION** Indicate the operation state during robot operation. Failure to indicate the state could lead to operators approaching the robot or to incorrect operation.
- ⚠ WARNING** When carrying out teaching work in the robot's movement range, always secure the priority right for the robot control. Failure to observe this could lead to personal injuries or damage if the robot is started with external commands.
- ⚠ CAUTION** Keep the jog speed as low as possible, and always watch the robot. Failure to do so could lead to interference with the workpiece or peripheral devices.
- ⚠ CAUTION** After editing the program, always confirm the operation with step operation before starting automatic operation. Failure to do so could lead to interference with peripheral devices because of programming mistakes, etc.
- ⚠ CAUTION** Make sure that if the safety fence entrance door is opened during automatic operation, the door is locked or that the robot will automatically stop. Failure to do so could lead to personal injuries.
- ⚠ CAUTION** Never carry out modifications based on personal judgments, or use non-designated maintenance parts. Failure to observe this could lead to faults or failures.

 **WARNING**

When the robot arm has to be moved by hand from an external area, do not place hands or fingers in the openings. Failure to observe this could lead to hands or fingers catching depending on the posture.

 **CAUTION**

Do not stop the robot or apply emergency stop by turning the robot controller's main power OFF. If the robot controller main power is turned OFF during automatic operation, the robot accuracy could be adversely affected. Moreover, it may interfere with the peripheral device by drop or move by inertia of the arm.

 **CAUTION**

Do not turn off the main power to the robot controller while rewriting the internal information of the robot controller such as the program or parameters. If the main power to the robot controller is turned off while in automatic operation or rewriting the program or parameters, the internal information of the robot controller may be damaged.

 **DANGER**

Do not connect the Handy GOT when using the GOT direct connection function of this product. Failure to observe this may result in property damage or bodily injury because the Handy GOT can automatically operate the robot regardless of whether the operation rights are enabled or not.

 **DANGER**

Do not remove the SSCNET III cable while power is supplied to the controller. Do not look directly at light emitted from the tip of SSCNET III connectors or SSCNET III cables. Eye discomfort may be felt if exposed to the light. (Reference: SSCNET III employs a Class 1 or equivalent light source as specified in JIS C 6802 and IEC60825-1 (domestic standards in Japan).)

 **DANGER**

Attach the cap to the SSCNET III connector after disconnecting the SSCNET III cable. If the cap is not attached, dirt or dust may adhere to the connector pins, resulting in deterioration connector properties, and leading to malfunction.

 **CAUTION**

Make sure there are no mistakes in the wiring. Connecting differently to the way specified in the manual can result in errors, such as the emergency stop not being released. In order to prevent errors occurring, please be sure to check that all functions (such as the teaching box emergency stop, customer emergency stop, and door switch) are working properly after the wiring setup is completed.

 **CAUTION**

Use the network equipments (personal computer, USB hub, LAN hub, etc) confirmed by manufacturer. The thing unsuitable for the FA environment (related with conformity, temperature or noise) exists in the equipments connected to USB. When using network equipment, measures against the noise, such as measures against EMI and the addition of the ferrite core, may be necessary. Please fully confirm the operation by customer. Guarantee and maintenance of the equipment on the market (usual office automation equipment) cannot be performed.

\*CR751-D or CR751-Q controller

Notes of the basic component are shown.

## ⚠ CAUTION

Please install the earth leakage breaker in the primary side supply power supply of the controller of CR751-D or CR751-Q because of leakage protection.

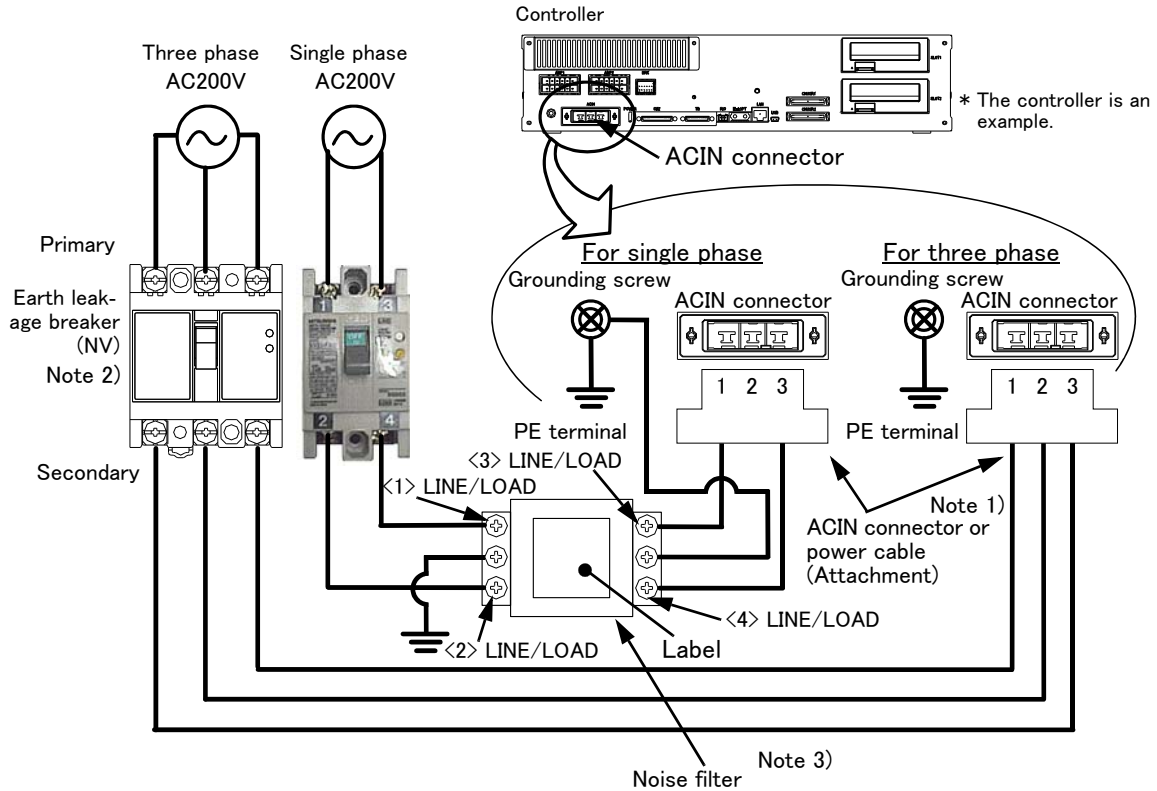

Note 1) Crimping swage is recommended for connecting the attachment ACIN connector (soldering is also possible)  
Recommendation compression tools: 234171-1(Tyco Electronics)

Note 2) The earth leakage breaker is the customer preparation. Always use the cover below.

Recommendation: For single primary power supply ..... NV30FAU-2P-10A-AC100-240V-30mA, (Cover: TCS-05FA2)

For three primary power supply ..... NV30FAU-3P-10A-AC100-240V-30mA, (Cover: TCS-05FA3)

Note 3) If necessary, as shown in the figure, connects the noise filter between ACIN terminal blocks and primary power supply.  
(Recommended noise filter: SUP-EL20-ER6 \*OKAYA ELECTRIC INDUSTRIES)

1) Please prepare the following: Leakage current breaker (with the terminal cover), cable for connecting the primary power supply (AWG #14 (2mm<sup>2</sup> or above), cables to ground the primary power supply (AWG #12 (3.5mm<sup>2</sup> or above).

The secondary power cable (with the ACIN connector) for single phase or three phase power is supplied with the product to match the specifications. When you build a cable suitable for your environment using the ACIN connector and the ACIN terminal supplied, prepare a secondary power cable (AWG #14 (2mm<sup>2</sup> or above).

2) Confirm that the primary power matches the specifications.

3) Confirm that the primary power is OFF and that the earth leakage breaker power switch is OFF.

4) Connect the secondary power cable.

a) When using the supplied power cable with the ACIN connector

Refer to the figure above and connect the cable from the secondary side of the earth leakage breaker.

b) When building a power cable using the ACIN connector and the ACIN terminals supplied

Connect the ACIN terminals with the secondary power cable (prepared by customers), and insert the ACIN terminals to the ACIN connector pins with the following numbers. Crimping caulking is recommended to connect the ACIN terminals.

For single phase: 1 and 3

For three phase: 1, 2, and 3

Refer to the figure above and connect the cable from the secondary side of the earth leakage breaker.

5) Connect this ACIN connector to the ACIN connector on the front of the controller.

6) Connect the grounding cable to the PE terminal. (M4 screw)

7) Connect the primary power cable to the primary side terminal of the earth leakage breaker.

## ⚠ CAUTION

Be careful of interference with peripheral equipment.

Especially don't give a shock to the shaft (J3 axis). When you install the hand, be careful not to knock at the shaft end by the hammer etc. The shaft may be damaged.

Take care also of the following items.

(1) The robot's locus of movement may change with specified speed.

Especially as for the corner section, short cut distance may change. Therefore, when beginning automatic operation, moves at low speed at first, and you should gather speed slowly with being careful of interference with peripheral equipment.

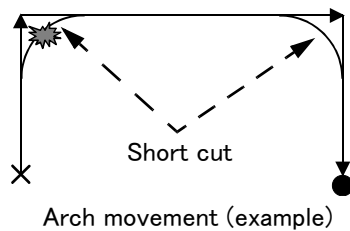

(2) It can be confirmed whether the specified position exist in the defined area by using the instruction command "Zone". It can utilize as one of the methods for collision evasion. Refer to the "detailed description of the instructions manual/function, and operation" of the separate volume for the details of the instruction command.

■Revision history

Date of print	Specifications No.	Details of revisions
2012-03-13	BFP-A8878	<ul style="list-style-type: none"> <li>• First print.</li> </ul>
2012-03-21	BFP-A8878-A	<ul style="list-style-type: none"> <li>• The painting color was corrected. (Error in writing)</li> <li>• Notes were added to the example of safety measures. (The measure against the noise, The electric specification of the output terminal)</li> </ul>
2012-04-04	BFP-A8878-B	<ul style="list-style-type: none"> <li>• CE marking specification was added.</li> </ul>
2012-05-17	BFP-A8878-C	<ul style="list-style-type: none"> <li>• The position repeatability was corrected (improvement).</li> <li>• ON voltage/ON current and OFF voltage/ OFF current of the parallel input-and-output interface were corrected (error in writing).</li> <li>• The mechanical stopper position to change the operating range to +/-130 degree was corrected to N12 (Error in writing)</li> </ul>
2012-06-05	BFP-A8878-D	<ul style="list-style-type: none"> <li>• Limitation of the electric current value of the relays (coil) connected to the external emergency stop input was added.</li> <li>• The connection method of the Fig.3-27 : AXMC terminal connector (CR750) corrected to "soldering."</li> <li>• The description of the capability value of pose repeatability was deleted.</li> </ul>
2012-09-03	BFP-A8878-E	<ul style="list-style-type: none"> <li>• The connector name of hand input signal/output signal of "Fig.2-24: Wiring and piping for hand" was corrected.</li> <li>• The power supply capacity was corrected.</li> </ul>
2012-10-04	BFP-A8878-F	<ul style="list-style-type: none"> <li>• The notes were added to "Fig 3-24: Example of EMC noise filter installation".</li> <li>• The lithium battery (ER6) was added to The United Nations' Recommendations on the Transport of Dangerous Goods.</li> <li>• The notes about installation of the controller and the robot arm were added. (neither direct rays nor the heat of lighting)</li> </ul>
2012-10-11	BFP-A8878-G	<ul style="list-style-type: none"> <li>• "Table 1-1: Combination of the robot arm and the controller" was corrected.</li> </ul>
2012-11-20	BFP-A8878-H	<ul style="list-style-type: none"> <li>• The statement about trademark registration was added.</li> <li>• The notes about the input-output connected to the controller were added. (do not ground the + side of 24V power supply prepared by customer)</li> <li>• "Declaration of Incorporation" was updated.</li> <li>• The metal plate which fixes "Hand internal wiring and piping set (option)" was changed to attachment of the robot arm in standard.</li> </ul>
2013-01-11	BFP-A8878-J	<ul style="list-style-type: none"> <li>• EC-Statement of Compliance was updated.</li> <li>• Note of the external emergency stop were added (opens the connector terminal at factory shipping).</li> <li>• The connectors of RH-3FH series machine cable (AMP1, AMP2, BRK) were combined as CN1 connector.</li> <li>• Type names of machine cables (option, special specifications) were changed. (No-CE specification)</li> </ul>
2013-02-15	BFP-A8878-K	<ul style="list-style-type: none"> <li>• Type name of CR751 controller was corrected. (formerly: CR751-03HD-0)</li> </ul>
2013-07-19	BFP-A8878-M	<ul style="list-style-type: none"> <li>• The simple spanner for resin nuts was added to the attachments of the external wiring/piping box (option).</li> <li>• "Declaration of Incorporation" and "EC-Statement of Compliance" were updated.</li> <li>• "Fig.2-28: Wiring and piping system diagram for hand and example the solenoid valve installation" was modified.</li> <li>• The cautions of operating in a low temperature environment or after a prolonged stop in "6.3 Precautions for handling" were modified.</li> <li>• The caution about fumigation of wood packing was added to "6.3 Precautions for handling".</li> </ul>
2013-09-19	BFP-A8878-N	<ul style="list-style-type: none"> <li>• "Fig.6-11: Limitations when connecting the relay etc. (CR750)" and "Fig.6-12: Limitations when connecting the relay etc. (CR751)" were corrected. (Error output → Emergency stop output, Contactor controleoutput for additional axes → Error output)</li> <li>• The descriptions of CR751-03HD1-0-S15 (CE marking specification controller) were added.</li> <li>• Type name of CR751 controller was corrected. (formerly: CR751-03HD)</li> <li>• The dimensions of screw hole position for fixing user wiring/piping were added.</li> <li>• The following descriptions of (5) in "Fig.2-24 : Wiring and piping for hand" were corrected. The power source wire only for the multifunctional hand → Spare wire The connector pins name of robot side and connector name of counter side were added. The connector pins name of counter side was corrected.</li> <li>• The descriptions of solenoid valve set were corrected, and explanations were added.</li> <li>• "Fig.2-28 : Wiring and piping system diagram for hand and example the solenoid valve installation" was corrected.</li> <li>• The useable length from the shaft end of Internal Wiring/Piping set for hand was corrected.</li> <li>• The descriptions about the ventilation duct which the robot of clean specification has were corrected.</li> </ul>



Date of print	Specifications No.	Details of revisions
2014-01-08	BFP-A8878-P	<ul style="list-style-type: none"> <li>• The cable fixation plate was added to "Fig.3-4: Outside dimensions of controller (CR751)".</li> <li>• The type name of the stopper for changing the operating range (J1 axis) in "Table 1-3: The list of robot option equipment and special specification" was corrected. (formerly: 1S-DH-02)</li> <li>• "Fig. 2-5: Relationship of the offset length and maximum velocity" was corrected.</li> <li>• Conditions for the flexed type cables were corrected.</li> <li>• The note about an ambient temperature was added to "2.1.1 Basic specifications".</li> <li>• The station numbers of the parallel I/O interface and the parallel I/O unit was corrected.</li> <li>• The description of "MELFA BASIC IV" was added to "Table 3-1: Specifications of controller".</li> </ul>
2014-03-31	BFP-A8878-R	<ul style="list-style-type: none"> <li>• The grounding representation was corrected.</li> <li>• The types of the ACIN terminal were added.</li> <li>• The dimension of pilot holes for positioning pin was added.</li> </ul>
2014-08-20	BFP-A8878-S	<ul style="list-style-type: none"> <li>• The cover and corporate logo mark of this manual was changed.</li> <li>• The statement about trademark registration was modified.</li> <li>• The explanation of CR751 controller was modified.</li> <li>• The description about screw holes using for tooling wiring and piping was added.</li> <li>• The note of turning ON the power supply for control (DCcable-2) for parallel I/O unit was added.</li> <li>• A safety relay in "example of safety measures (wiring example 5)" both CR750 and CR751 controller were changed.</li> <li>• "Declaration of Incorporation" and "EC-Statement of Compliance" were updated.</li> </ul>
2014-12-17	BFP-A8878-T	<ul style="list-style-type: none"> <li>• Allowance value of the offset amount was added to "2.2.2 Mass capacity".</li> <li>• The description of how to change the operating range moved into "INSTRUCTION MANUAL/ROBOT ARM SETUP &amp; MAINTENANCE".</li> <li>• Correction of errors in the Specifications discussion materials. (Network vision sensor: 4D-2CG5***-PKG was deleted.)</li> <li>• The corporate logo mark of illustrations in this manual was changed.</li> </ul>
2015-02-10	BFP-A8878-U	<ul style="list-style-type: none"> <li>• The description in case the ethernet cable is used as a backup wiring for data communication was added.</li> </ul>

## ■ Introduction

This series offers small-size industrial robots developed using Mitsubishi's latest technology. They are especially designed to handle and assemble mechanical parts. They are Mitsubishi's answer to the customer's need to achieve a compact manufacturing facility capable of highly flexible production, as necessitated by the diffusion of high-density product groups and the shorter product life cycles that have become common-place in recent years.

However, to comply with the target application, a work system having a well-balanced robot arm, peripheral devices or robot and hand section must be structured.

When creating these standard specifications, we have edited them so that the Mitsubishi robot's characteristics and specifications can be easily understood by users considering the implementation of robots. However, if there are any unclear points, please contact your nearest Mitsubishi branch or dealer.

Mitsubishi hopes that you will consider these standard specifications and use our robots.

Note that in this specification document the specifications related to the robot arm is described [Page 9, "2 Robot arm"](#), the specifications related to the controller [Page 63, "3 Controller"](#), and software functions and a command list [Page 130, "4 Software"](#) separately.

This document has indicated the specification of the following types robot.

\*RH-3FH-D series

· About CE Marking in the automization system

The Guidelines of the measures against EMC in the automization system manufactured by the customer is shown in [Page 154, "6.4 EMC installation guideline"](#).

Please refer to it and carry out the measures against EMC of the automization system of the customer.

- No part of this manual may be reproduced by any means or in any form, without prior consent from Mitsubishi.
- The contents of this manual are subject to change without notice.
- The specifications values are based on Mitsubishi standard testing methods.
- The information contained in this document has been written to be accurate as much as possible. Please interpret that items not described in this document "cannot be performed." or "alarm may occur".  
Please contact your nearest dealer if you find any doubtful, wrong or skipped point.
- This specifications is original.
- Microsoft, Windows, Windows XP, Windows Vista, Windows 7, Windows 8, Windows 8.1 are either registered trademarks or trademarks of Microsoft Corporation in the United States and/or other countries.
- The official name of Windows® is Microsoft®Windows®Operating System.
- Windows®XP, Windows Vista®, Windows® 7, Windows® 8, Windows® 8.1 are either product names of Microsoft Corporation in the United States.
- Ethernet is registered trademarks or trademarks of Xerox Corporation in the United States.
- All other company names and production names in this document are the trademarks or registered trademarks of their respective owners.

# Contents

	Page
1 General configuration .....	1-1
1.1 Structural equipment .....	1-1
1.1.1 Standard structural equipment .....	1-1
1.1.2 Special specifications .....	1-1
1.1.3 Options .....	1-1
1.1.4 Maintenance parts .....	1-1
1.2 Model type name of robot .....	1-2
1.2.1 How to identify the robot model .....	1-2
1.2.2 Combination of the robot arm and the controller .....	1-3
1.3 CE marking specifications .....	1-3
1.4 Indirect export .....	1-3
1.5 Instruction manuals .....	1-3
1.6 Contents of the structural equipment .....	1-4
1.6.1 Robot arm .....	1-4
1.6.2 Controller .....	1-5
1.7 Contents of the Option equipment and special specification .....	1-6
2 Robot arm .....	2-9
2.1 Standard specifications .....	2-9
2.1.1 Basic specifications .....	2-9
(1) Standard specification .....	2-9
(2) Clean specification .....	2-11
2.1.2 The counter-force applied to the installation surface .....	2-12
2.2 Definition of specifications .....	2-13
2.2.1 Pose repeatability .....	2-13
2.2.2 Mass capacity .....	2-14
2.2.3 Relationships Among Mass Capacity, Speed, and Acceleration/Deceleration Speed .....	2-15
(1) Setting Load Capacity and Size (Hand Conditions) .....	2-15
2.2.4 Vibrations at the Tip of the Arm during Low-Speed Operation of the Robot .....	2-15
2.2.5 Vibration of shaft (J3 axis) position and arm end .....	2-16
(1) Relationship Between Mass Capacity and Speed .....	2-16
(2) Relationship Between Height of Shaft (J3 Axis) and Acceleration/Deceleration Speed .....	2-17
(3) Relation between offset length and the maximum speed .....	2-18
(4) Time to reach the position repeatability .....	2-19
2.2.6 Collision detection .....	2-19
2.2.7 Protection specifications .....	2-20
(1) Types of protection specifications .....	2-20
2.2.8 Clean specifications .....	2-20
(1) Types of clean specifications .....	2-20
2.3 Names of each part of the robot .....	2-22
2.4 Outside dimensions • Operating range diagram .....	2-23
2.4.1 Outside dimensions • Operating range diagram .....	2-23
(1) Standard Specification .....	2-23
(2) Clean Specification .....	2-29
2.4.2 Mechanical interface and Installation surface .....	2-35
2.4.3 Outside dimensions of machine cables .....	2-36
(1) Connection with the CR750 controller .....	2-36
(2) Connection with the CR751 controller .....	2-36
2.5 Tooling .....	2-37
2.5.1 Wiring and piping for hand .....	2-37
2.5.2 Internal air piping .....	2-38
(1) Standard type .....	2-38
(2) Clean type .....	2-38
2.5.3 Internal wiring for the hand output cable .....	2-38
2.5.4 Internal wiring for the hand input cable .....	2-38
2.5.5 Ethernet cable .....	2-38

# Contents

	Page
2.5.6 About the Installation of Tooling Wiring and Piping (Examples of Wiring and Piping) .....	2-39
(1) Example of wiring and piping <1> .....	2-40
(2) Wiring and piping example <2> .....	2-40
(3) Precautions for the clean specification .....	2-41
2.5.7 Wiring and piping system diagram for hand .....	2-42
2.5.8 Electrical specifications of hand input/output .....	2-43
2.5.9 Air supply circuit example for the hand .....	2-44
2.6 Shipping special specifications, options, and maintenance parts .....	2-45
2.6.1 Shipping special specifications .....	2-45
(1) Machine cable .....	2-46
2.7 Options .....	2-47
(1) Machine cable extension .....	2-48
(2) Changes J1 axis operating range .....	2-52
(3) Solenoid valve set .....	2-53
(4) Hand input cable .....	2-55
(5) Hand output cable .....	2-56
(6) Hand curl tube .....	2-57
(7) Internal Wiring/Piping set for hand .....	2-58
(8) External Wiring/Piping box .....	2-59
2.8 About Overhaul .....	2-61
2.9 Maintenance parts .....	2-62
3 Controller .....	3-63
3.1 Standard specifications .....	3-63
3.1.1 Basic specifications .....	3-63
3.1.2 Protection specifications and operating supply .....	3-64
3.2 Names of each part .....	3-65
3.2.1 Controller .....	3-65
(1) CR750 controller .....	3-65
(2) CR751 controller .....	3-67
3.3 Outside dimensions/Installation dimensions .....	3-69
3.3.1 Outside dimensions .....	3-69
(1) CR750 controller .....	3-69
(2) CR751 controller .....	3-70
3.3.2 Installation dimensions .....	3-71
(1) CR750 controller .....	3-71
(2) CR751 controller .....	3-73
3.4 External input/output .....	3-75
3.4.1 Types .....	3-75
3.5 Dedicated input/output .....	3-76
3.6 Emergency stop input and output etc. ....	3-79
3.6.1 Connection of the external emergency stop .....	3-79
(1) CR750 controller .....	3-80
(2) CR751 controller .....	3-84
3.6.2 Special stop input (SKIP) .....	3-87
(1) CR750 controller .....	3-87
(2) CR751 controller .....	3-88
3.6.3 Door switch function .....	3-89
3.6.4 Enabling device function .....	3-89
(1) When door is opening .....	3-89
(2) When door is closing .....	3-90
(3) Automatic Operation/Jog Operation/Brake Release and Necessary Switch Settings .....	3-90
3.7 Mode changeover switch input .....	3-91
(1) Specification of the key switch interface .....	3-91
(2) Connection of the mode changeover switch input .....	3-92
3.8 Additional Axis Function .....	3-93

# Contents

	Page
3.8.1 Wiring of the Additional Axis Interface .....	3-93
(1) CR750 controller .....	3-93
(2) CR751 controller .....	3-94
3.9 Magnet contactor control connector output (AXMC) for addition axes .....	3-97
(1) CR750 controller .....	3-98
(2) CR751 controller .....	3-98
3.10 Options .....	3-99
(1) Teaching pendant (T/B) .....	3-100
(2) Parallel I/O interface .....	3-103
(3) External I/O cable .....	3-108
(4) Parallel I/O unit .....	3-110
(5) External I/O cable .....	3-121
(6) CC-Link interface .....	3-123
(7) RT ToolBox2/RT ToolBox2 mini .....	3-126
(8) Instruction Manual (bookbinding) .....	3-128
3.11 Maintenance parts .....	3-129
4 Software .....	4-130
4.1 List of commands .....	4-130
4.2 List of parameters .....	4-133
5 Instruction Manual .....	5-135
5.1 The details of each instruction manuals .....	5-135
6 Safety .....	6-136
6.1 Safety .....	6-136
6.1.1 Self-diagnosis stop functions .....	6-136
6.1.2 External input/output signals that can be used for safety protection measures .....	6-137
6.1.3 Precautions for using robot .....	6-137
6.1.4 Safety measures for automatic operation .....	6-138
6.1.5 Safety measures for teaching .....	6-138
6.1.6 Safety measures for maintenance and inspections, etc. ....	6-138
6.1.7 Examples of safety measures .....	6-139
(1) CR750 controller .....	6-139
(2) CR751 controller .....	6-144
(3) External emergency stop connection [supplementary explanation] .....	6-149
6.2 Working environment .....	6-152
6.3 Precautions for handling .....	6-152
6.4 EMC installation guideline .....	6-154
6.4.1 Outlines .....	6-154
6.4.2 EMC directive .....	6-154
6.4.3 EMC measures .....	6-155
6.4.4 Component parts for EMC measures .....	6-155
(1) Ferrite core .....	6-155
(2) Line noise filter .....	6-155
7 Appendix .....	Appendix-156
Appendix 1 : Specifications discussion material .....	Appendix-156

## 1 General configuration

### 1.1 Structural equipment

Structural equipment consists of the following types.

#### 1.1.1 Standard structural equipment

The following items are enclosed as a standard.

- (1) Robot arm
- (2) Controller
- (3) Machine cable
- (4) Robot arm installation bolts
- (5) Safety manual, CD-ROM (Instruction manual)
- (6) Guarantee card

#### 1.1.2 Special specifications

For the special specifications, some standard configuration equipment and specifications have to be changed before factory shipping. Confirm the delivery date and specify the special specifications at the order.

#### 1.1.3 Options

User can install options after their delivery.

#### 1.1.4 Maintenance parts

Materials and parts for the maintenance use.

## 1.2 Model type name of robot

This robot has arranged the type name corresponding to load mass, arm length, and environment specification. Details are shown below, please select the robot suitable for the customer's use.

### 1.2.1 How to identify the robot model

**RH - 3 FH □□ △△ ○ - 1 D ▲ - Sxx**

(a) (b) (c) (d) (e) (f) (g) (h) (i) (j)

- (a). RH.....Indicates the horizontal multiple-joint robot.
- (b). 3.....Indicates the maximum load.  
3: 3kg
- (c). FH.....Indicates the FH series.
- (d). □□ .....Indicates the arm length.  
Ex.)  
35: 350mm  
45: 450mm  
55: 550mm
- (e). △△ .....Indicates the vertical stroke length.  
Ex.)  
12: 120mm stroke  
15: 150mm stroke
- (f). ○ .....Indicates environment specification.  
Ex.)  
Omitted: General specifications  
C: Clean specifications
- (g). 1 .....Indicates the controller series.  
Ex.)  
Omitted: CR750 controller  
1: CR751 controller
- (h). D .....Indicates the controller type.  
D: Stand alone type
- (i). ▲ .....Technical standard of Conformity.  
Ex.)  
Omitted: No conformity of technical standard.  
1: Conforms to the CE Marking
- (j). - S xx.....Indicates a special model. In order, limit special specification.

### 1.2.2 Combination of the robot arm and the controller

Table 1-1 : Combination of the robot arm and the controller

Protection specification	Robot arm	Arm length (mm)	J3-axis stroke (mm)	Controller
General-purpose environment	RH-3FH3515-1D	350	150	CR751-03HD-0
	RH-3FH4515-1D	450		
	RH-3FH5515-1D	550		
Clean specifications	RH-3FH3512C-1D	350	120	
	RH-3FH4512C-1D	450		
	RH-3FH5512C-1D	550		

### 1.3 CE marking specifications

The robot shown in [Table 1-2](#) is the CE Marking specification.

Table 1-2 : Robot models with CE marking specifications

Robot type <sup>Note1)</sup>	Controller	External signal logic	Language setting
RH-3FH <sup>xx</sup> xyy-D1-S15	CR750-03HD1-1-S15 <sup>Note2)</sup>	Source type	English (ENG)
RH-3FH <sup>xx</sup> xyyC-D1-S15 <sup>Note3)</sup>			
RH-3FH <sup>xx</sup> xyy-1D1-S15	CR751-03HD1-0-S15 <sup>Note4)</sup>		
RH-3FH <sup>xx</sup> xyyC-1D1-S15 <sup>Note3)</sup>			

Note1) The "xx" indicate the arm length, "yy" indicate J3-axis stroke.

Note2) The specification and the handling method of the controller are the same as standard type controller CR750-03HD-1.

Note3) This robot is the clean specification. As long as there is no special description, refers to the contents of RH-3FH<sup>xx</sup>xyyC (clean specification).

Note4) The specification and the handling method of the controller are the same as standard type controller CR751-03HD-0.

### 1.4 Indirect export

The display in English is available by setting parameter LNG as "ENG."

### 1.5 Instruction manuals

The instruction manuals supplied in CD-ROM, except for the Safety Manual. This CD-ROM (electronic manual) includes instruction manuals in both Japanese and English versions.



## 1.6 Contents of the structural equipment

### 1.6.1 Robot arm

The list of structural equipment is shown in below.

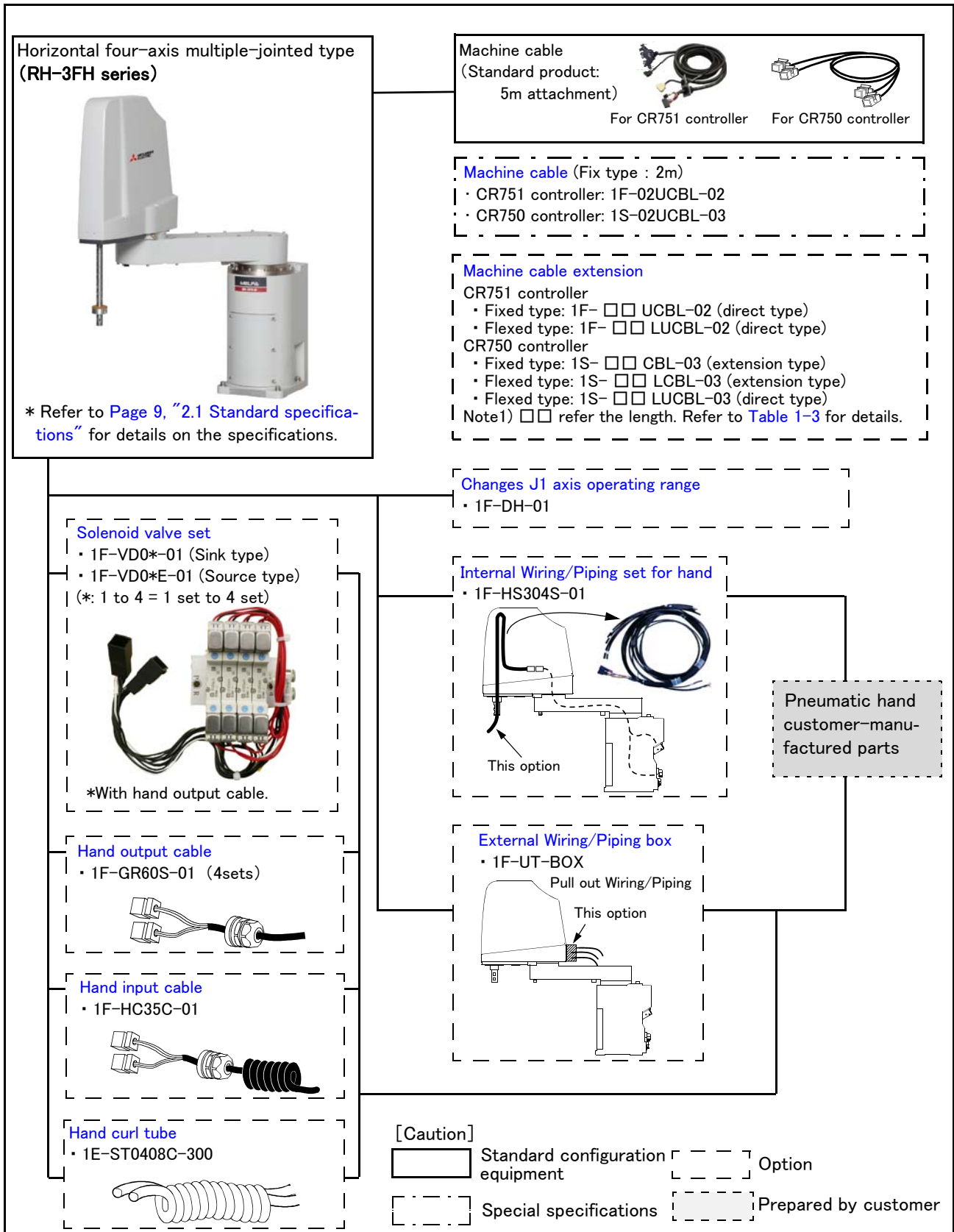

Fig.1-1 : Structural equipment

1.6.2 Controller

The devices shown below can be installed on the controller.

The controllers that can be connected differ depending on the specification of the robot. (Refer to Page 2, "1.2 Model type name of robot".)

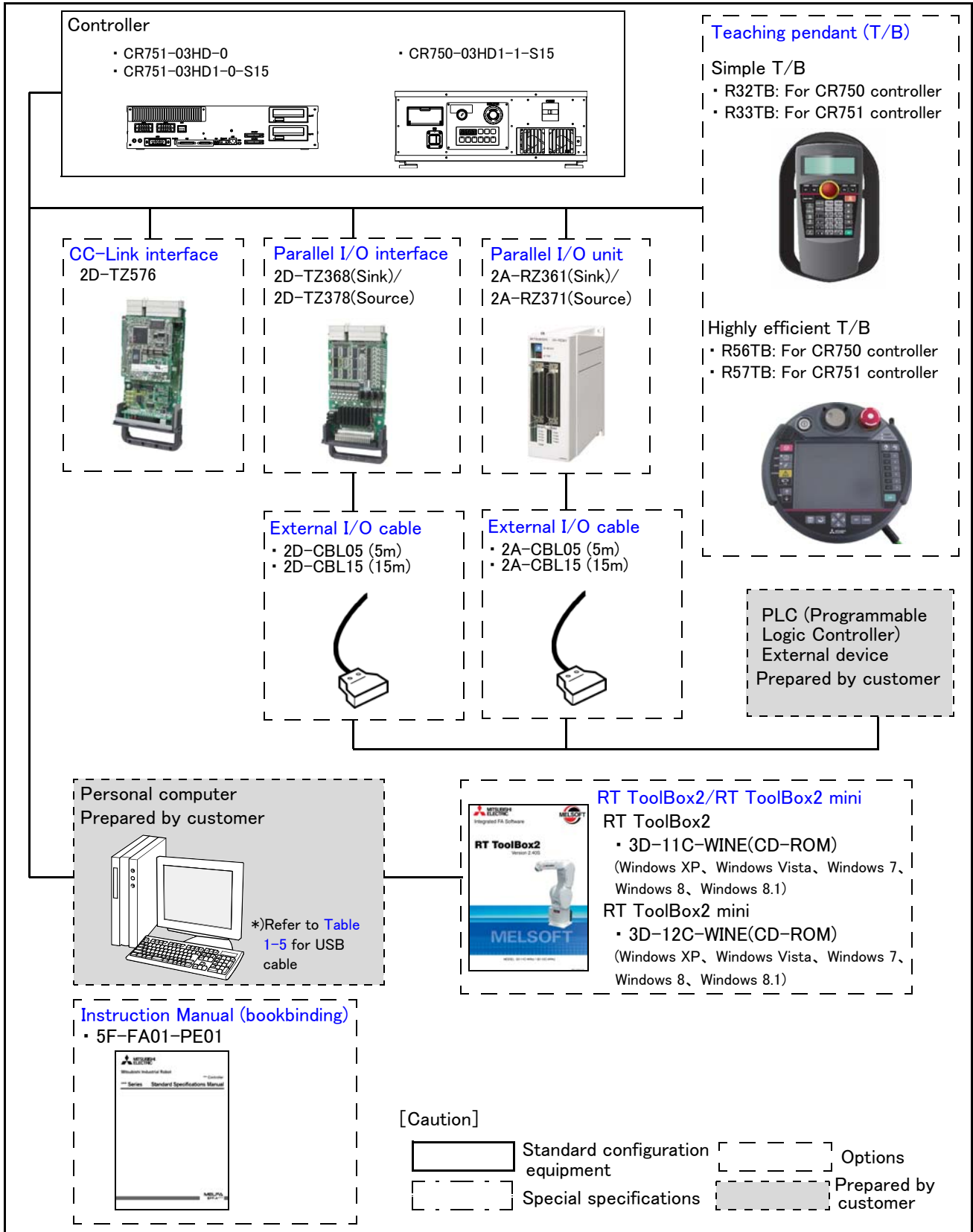

Fig.1-2 : Structural equipment

## 1.7 Contents of the Option equipment and special specification

A list of all Optional equipment and special specifications are shown below.

Table 1-3 : The list of robot option equipment and special specification

Item	Type	Specifications	Classification <sup>Note1)</sup>		Description
			CR750	CR751	
Stopper for changing the operating range (J1 axis)	1F-DH-01	The stopper parts for J1 axis	○	○	This must be installed by the customer.
Machine cable (Replaced to shorter cable)	1S-02UCBL-03	For fixing (Set of power and signal)	○・□	-	2m (A 2m cable is supplied instead of the 5m cable that is supplied as standard)
	1F-02UCBL-02	For fixing (Set of power and signal)	-	○・□	
Machine cable extension (extension type)	1S- □□ CBL-03	For fixing (Set of power and signal)	○	-	" □□ " in type shows the length of the cables as follows. 05=5m, 10=10m, 15=15m
	1S- □□ LCBL-03	For flexing (Set of power and signal)	○	-	
Machine cable extension (direct type)	1S- □□ LUCBL-03	For flexing (Set of power and signal)	○	-	" □□ " in type shows the length of the cables as follows. 10=10m, 15=15m, 20=20m
	1F- □□ UCBL-02	For fixing (Set of power and signal)	-	○	
	1F- □□ LUCBL-02	For flexing (Set of power and signal)	-	○	
Solenoid valve set	1F-VD01-01/VD01E-01	1 set (Sink type)/(Source type)	○	○	The solenoid-valve set for the hand of the customer setup 1F-VD0*-01: Sink type 1F-VD0*E-01: Source type
	1F-VD02-01/VD02E-01	2 set (Sink type)/(Source type)	○	○	
	1F-VD03-01/VD03E-01	3 set (Sink type)/(Source type)	○	○	
	1F-VD04-01/VD04E-01	4 set (Sink type)/(Source type)	○	○	
Hand input cable	1F-HC35C-01	Robot side: connector. Hand side: wire.	○	○	The cable is connected to the sensor by the customer. Attaches the cable clamp (drip proof type)
Hand output cable	1F-GR60S-01	Robot side: connector Hand side: wire	○	○	The cable is connected to the hand output connector by the customer. Attaches the cable clamp (drip proof type) Straight cable 600mm (total length)
Hand curl tube	1E-ST0408C-300	For solenoid valve 4set.:Φ4x8	○	○	Curl type air tube
External Wiring/Piping box	1F-UT-BOX	For solenoid valve 4set.:Φ4x8	○	○	Box which pulls out the Wire/Piping (Hand I/O cable, Hand curl tube)
Internal Wiring/Piping set for hand	1F-HS304S-01	Hand input cable (four signal lines and two power lines), φ3 four hoses	○	○	Wiring/Piping to pass in the shaft Reducers (φ4 to φ3: 8pcs) are Attached.

Note1) Distinction of ○ (is option) and □ (is special specification at shipping) is shown for each pair with the controller.

Table 1-4 : The list of controller option equipment and special specification

Item	Type	Specifications	Classification Note1)		Description
			CR750	CR751	
Simple teaching pendant	R32TB	Cable length 7m	○	—	With 3-position enable switch IP65
	R32TB-15	Cable length 15m	○	—	
	R33TB	Cable length 7m	—	○	
	R33TB-15	Cable length 15m	—	○	
Highly efficient teaching pendant	R56TB	Cable length 7m	○	—	
	R56TB-15	Cable length 15m	○	—	
	R57TB	Cable length 7m	—	○	
	R57TB-15	Cable length 15m	—	○	
Parallel I/O Interface	2D-TZ368 (Sink type)	DO: 32 point DI: 32 point Insulated type output signal (0.1A/24V /point)	○	○	The card type external input-and-output interface. Install to the slot of controller.
	2D-TZ378 (Source type)	DO: 32 point/ DI: 32 point Insulated type output signal (9mA/ 24V /point)			
External I/O cable (For Parallel I/O Interface)	2D-CBL05	5m	○	○	Use to connect the external peripheral device to the parallel input/output interface.
	2D-CBL15	15m	○	○	
Parallel I/O Unit	2A-RZ361 (Sink type)	DO: 32 point/ DI: 32 point Insulated type output signal (0.1A/24V /point)	○	○	The unit for expansion the external input/output. Electrical isolated Type (100mA/Point)
	2A-RZ371 (Source type)	DO: 32 point/ DI: 32 point Insulated type output signal (7mA/ 24V /point)			
External I/O cable (For Parallel I/O Unit)	2A-CBL05	5m	○	○	Use to connect the external peripheral device to the parallel input/output unit
	2A-CBL15	15m	○	○	
CC-Link interface	2D-TZ576	Only Intelligent device station, Local station	○	○	For MELSEC PLC with CC-Link connection.
RT ToolBox2 (Personal computer Support software)	3D-11C-WINE	CD-ROM	○	○	Windows XP、Windows Vista、Windows 7、Windows 8、Windows 8.1 (With the simulation function)
RT ToolBox2 mini (Personal computer Support software mini)	3D-12C-WINE	CD-ROM	○	○	Windows XP、Windows Vista、Windows 7、Windows 8、Windows 8.1
Instruction Manual	5F-FA01-PE01	RH-3FH-D series	○	○	

Note1) Distinction of ○ (is option) and □ (is special specification at shipping) is shown for each pair with the controller.

[Reference]:The recommendation products of the USB cable are shown below

Table 1-5 : Recommendation article of the USB cable

Name	Type name	Supplier
USB cable (USB A type-USB mini B type)	KU-AMB530	SANWA SUPPLY INC.
	USB-M53	ELECOM CO., LTD.
	GT09-C30USB-5P	MITSUBISHI ELECTRIC SYSTEM & SERVICE CO., LTD.
	MR-J3USBCBL3M	MITSUBISHI ELECTRIC CO., LTD.
USB adapter (USB B type-USB mini B type)	AD-USBBFTM5M	ELECOM CO., LTD.



### Caution

Be careful to the USB cable to apply neither the static electricity nor the noise. Otherwise, it becomes the cause of malfunction.



### Caution

Use the network equipments (personal computer, USB hub, LAN hub, etc) confirmed by manufacturer. The thing unsuitable for the FA environment (related with conformity, temperature or noise) exists in the equipments connected to USB. When using network equipment, measures against the noise, such as measures against EMI and the addition of the ferrite core, may be necessary. Please fully confirm the operation by customer. Guarantee and maintenance of the equipment on the market (usual office automation equipment) cannot be performed.

## 2 Robot arm

### 2.1 Standard specifications

#### 2.1.1 Basic specifications

##### (1) Standard specification

Table 2-1 : Standard specifications of robot arm

Item		Unit	Specifications		
Type			RH-3FH3515	RH-3FH4515	RH-3FH5515
Environment			Standard specification		
Installation posture			On floor		
Degree of freedom			4		
Structure			Horizontal, multiple-joint type		
Drive system			AC servo motor		
Position detection method			Absolute encoder		
Motor capacity	J1	W	200		
	J2	W	100		
	J3 (Z)	W	100		
	J4 ( $\theta$ axis)	W	50		
Brake			J1, J2, J4: no brake, J3: with brake		
Arm length	No. 1 arm	mm	125	225	325
	No. 2 arm	mm	225		
Max.reach radius( No. 1+ No. 2)		mm	350	450	550
Operating range	J1	deg	$\pm 170$		
	J2	deg	$\pm 145$		
	J3 (Z)	mm	150		
	J4 ( $\theta$ axis)	deg	$\pm 360$		
Speed of motion <sup>Note1)</sup>	J1	deg/s	400		
	J2	deg/s	720		
	J3 (Z)	mm/s	1,100		
	J4 ( $\theta$ axis)	deg/s	3,000		
Maximum horizontal composite speed <sup>Note2)</sup>		mm/s	6,800	7,500	8,300
Cycle time <sup>Note3)</sup>		sec	0.41	0.46	0.51
Load	Rating	kg	1		
	Maximum	(N)	3		
Z axis pressing force <sup>Note4)</sup>	Maximum	N	82		
Allowable inertia	Rating	kg · m <sup>2</sup>	0.005		
	Maximum		0.06		
Pose repeatability <sup>Note5)</sup>	X-Y direction	mm	$\pm 0.010$	$\pm 0.010$	$\pm 0.012$
	J3 (Z)	mm	$\pm 0.010$		
	J4 ( $\theta$ axis)	deg	$\pm 0.004$		
Ambient temperature <sup>Note6)</sup>		°C	0 to 40		
Mass		k	29		32
Tool wiring			<ul style="list-style-type: none"> <li>· Input 8 points/Output 8 points, (total 20 cores)</li> <li>· Dedicated signal cable for multifunctional hand (Two cores + Power cable two cores)</li> <li>· Ethernet cable one cable (100BASE-TX, eight cores) <sup>Note7)</sup></li> </ul>		
Tool pneumatic pipes			Primary: $\phi 6$ x two hoses, Secondary: $\phi 4$ x eight hoses <sup>Note8)</sup>		
Supply pressure		MPa	0.5 $\pm$ 10%		
Protection specification <sup>Note9)</sup>			IP20		
Painting color			Light gray (Equivalent to Munsell: 0.6B7.6/0.2)		

Note1) The maximum speed is the value which applied MvTune2 (high-speed movement mode).

Note2) At the maximum speed on the X-Y flat surface in the robot's control point, it is obtained with each speed of J1, J2, and J4. The control point is the position offset by the rated inertia from the flange.

Note3) The value of the following movement which applied MvTune2 (high-speed movement mode) with the carrying mass of 2kg.

- The cycle time may increase with the case where the positioning accuracy of the work etc. is necessary, or by the moving position.

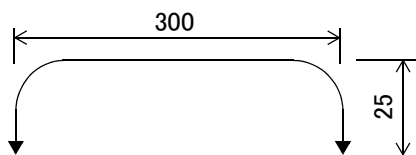

Note4) This is the downwards pressing force that occurs at the end of the load when the maximum load is on board and the J1, J2 and J4 axis are in their resting state. Please operate at this level or below. When pressing for long periods of time, an excess load error may occur. Please operate in a manner that does not cause errors.

Note5) The pose repeatability details are given in [Page 13, "2.2.1 Pose repeatability"](#).

Note6) Sets the robot's operating environmental temperature as parameter OLTMX. Corresponding to the environment, the continuous control action performance and the overload-protection function are optimized. (Refers to "Optimizing the overload level" described in "Chapter 5 Functions set with parameters" of separate instruction manual/ Detailed explanations of functions and operations for details.)

Note7) The 8-wire cable designated for LAN wiring can also be used for backup wiring.

Note8) The  $\phi 4$  secondary piping can be obtained with the electromagnetic valve (option). Details regarding the electromagnetic valve (optional) are shown on [Page 53, "\(3\) Solenoid valve set"](#).

Note9) The protection specification details are given in [Page 20, "2.2.7 Protection specifications"](#).

## (2) Clean specification

Table 2-2 : Standard specifications of robot arm (Clean specification)

Item		Unit	Specifications		
Type			RH-3FH3512C	RH-3FH4512C	RH-3FH5512C
Environment			Standard specification		
Installation posture			On floor		
Degree of freedom			4		
Structure			Horizontal, multiple-joint type		
Drive system			AC servo motor		
Position detection method			Absolute encoder		
Motor capacity	J1	W	200		
	J2	W	100		
	J3 (Z)	W	100		
	J4 ( $\theta$ axis)	W	50		
Brake			J1, J2, J4: no brake, J3: with brake		
Arm length	No. 1 arm	mm	125	225	325
	No. 2 arm	mm	225		
Max.reach radius( No. 1+ No. 2)		mm	350	450	550
Operating range	J1	deg	$\pm 170$		
	J2	deg	$\pm 145$		
	J3 (Z)	mm	120		
	J4 ( $\theta$ axis)	deg	$\pm 360$		
Speed of motion <sup>Note1)</sup>	J1	deg/s	420		
	J2	deg/s	720		
	J3 (Z)	mm/s	1,100		
	J4 ( $\theta$ axis)	deg/s	3,000		
Maximum horizontal composite speed <sup>Note2)</sup>		mm/s	6,800	7,500	8,300
Cycle time <sup>Note3)</sup>		sec	0.41	0.46	0.51
Load	Rating	kg	1		
	Maximum	(N)	3		
Z axis pressing force <sup>Note4)</sup>	Maximum	N	82		
Allowable inertia	Rating	kg · m <sup>2</sup>	0.005		
	Maximum		0.06		
Pose repeatability <sup>Note5)</sup>	X-Y direction	mm	$\pm 0.010$	$\pm 0.010$	$\pm 0.012$
	J3 (Z)	mm	$\pm 0.010$		
	J4 ( $\theta$ axis)	deg	$\pm 0.004$		
Ambient temperature <sup>Note6)</sup>		°C	0 to 40		
Mass		k	29		32
Tool wiring			<ul style="list-style-type: none"> <li>· Input 8 points/Output 8 points, (total 20 cores)</li> <li>· Dedicated signal cable for multifunctional hand (Two cores + Power cable two cores)</li> <li>· Ethernet cable one cable (100BASE-TX, eight cores) <sup>Note7)</sup></li> </ul>		
Tool pneumatic pipes			Primary: $\phi 6$ x two hoses, Secondary: $\phi 4$ x eight hoses <sup>Note8)</sup>		
Supply pressure		MPa	$0.5 \pm 10\%$		
Protection specification <sup>Note9)</sup>			Clean specification: ISO class 3		
Painting color			Light gray (Equivalent to Munsell: 0.6B7.6/0.2)		

Note1) The maximum speed is the value which applied MvTune2 (high-speed movement mode).

Note2) At the maximum speed on the X-Y flat surface in the robot's control point, it is obtained with each speed of J1, J2, and J4. The control point is the position offset by the rated inertia from the flange.



Note3) The value of the following movement which applied MvTune2 (high-speed movement mode) with the carrying mass of 2kg.

- The cycle time may increase with the case where the positioning accuracy of the work etc. is necessary, or by the moving position.

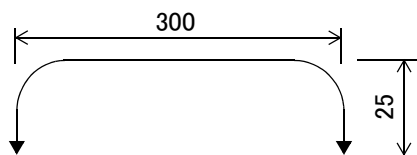

Note4) This is the downwards pressing force that occurs at the end of the load when the maximum load is on board and the J1, J2 and J4 axis are in their resting state. Please operate at this level or below. When pressing for long periods of time, an excess load error may occur. Please operate in a manner that does not cause errors.

Note5) The pose repeatability details are given in [Page 13, "2.2.1 Pose repeatability"](#).

Note6) Sets the robot's operating environmental temperature as parameter OLTMX. Corresponding to the environment, the continuous control action performance and the overload-protection function are optimized. (Refers to "Optimizing the overload level" described in "Chapter 5 Functions set with parameters" of separate instruction manual/ Detailed explanations of functions and operations for details.)

Note7) The 8-wire cable designated for LAN wiring can also be used for backup wiring.

Note8) The  $\phi 4$  secondary piping can be obtained with the electromagnetic valve (option). Details regarding the electromagnetic valve (optional) are shown on [Page 53, "\(3\) Solenoid valve set"](#).

Note9) The details of the clean specifications are described in [Page 20, "2.2.8 Clean specifications"](#). The conditions necessary to guarantee cleanliness are as follows: clean room down flow greater than 0.3 m/s, robot internal suction of 30 to 50 L/min, and installation of an exhaust duct at the rear of the robot's main base. A  $\phi 8$  joint has been prepared at the rear of the base for suction.

The protection specification details are given in [Page 20, "2.2.7 Protection specifications"](#).

### 2.1.2 The counter-force applied to the installation surface

The counter-force applied to the installation surface for the strength design of the robot installation surface is shown.

Table 2-3 : Value of each counter-force

Item	Unit	Value
Falls moment: $M_L$	N · m	240
Torsion moment: $M_T$	N · m	255
Horizontal translation force: $F_H$	N	810
Vertical translation force: $F_V$	N	380

## 2.2 Definition of specifications

The accuracy of pose repeatability mentioned in catalogs and in the specification manual is defined as follows.

### 2.2.1 Pose repeatability

For this robot, the pose repeatability is given in accordance with JIS B 8432 (Pose repeatability). Note that the value is based on 100 measurements (although 30 measurements are required according to JIS).

[Caution] The specified "pose repeatability" is not guaranteed to be satisfied under the following conditions.

- [1] Operation pattern factors
  - 1) When an operation that approaches from different directions and orientations are included in relation to the teaching position during repeated operations
  - 2) When the speed at teaching and the speed at execution are different
- [2] Load fluctuation factor
  - 1) When work is present/absent in repeated operations
- [3] Disturbance factor during operation
  - 1) Even if approaching from the same direction and orientation to the teaching position, when the power is turned OFF or a stop operation is performed halfway
- [4] Temperature factors
  - 1) When the operating environment temperature changes
  - 2) When accuracy is required before and after a warm-up operation
- [5] Factors due to differences in accuracy definition
  - 1) When accuracy is required between a position set by a numeric value in the robot's internal coordinate system and a position within the actual space
  - 2) When accuracy is required between a position generated by the pallet function and a position within the actual space

## 2.2.2 Mass capacity

The robot's mass capacity is expressed solely in terms of mass, but even for tools and works of similar mass, eccentric loads will have some restrictions. When designing the tooling or when selecting a robot, consider the following issues.

- (1) The tooling should have the value less or equal than the smaller of the allowable moment of inertia found in [Page 9, "2.1.1 Basic specifications"](#).
- (2) [Fig. 2-1](#) shows the distribution dimensions for the center of gravity in the case where the volume of the load is relatively small. Use this figure as a reference when designing the tooling. Please use the robot in the allowable moment of inertia of maximum moment of inertia shown in [Fig. 2-1](#).

[Caution] The mass capacity is greatly influenced by the operating speed of the robot and the motion posture. Even if you are within the allowable range mentioned previously, a vibration, an overload or generate an overcurrent alarm could occur. In such cases, please reduce acceleration and deceleration (Accel command) speeds and movement speed (Ovr command). Although the standard value to reduce is 50% for each command, please adjust corresponding to the movement posture. Refer to separate "Instruction Manual/Detailed Explanation of Functions and Operations" for details of each command. Moreover, if hand/workpiece parameters are not set exactly, the similar phenomenon will be easier to occur.

[Caution] Refer to [Page 15, "2.2.3 Relationships Among Mass Capacity, Speed, and Acceleration/Deceleration Speed"](#), and set the values of the mass, magnitude, and distance to the centroid of a tool and a workpiece to parameters.

If parameters are not set exactly, the lifetime of reduction gears, a belt, etc. is affected.

[Caution] The overhang amount of the load, such as the mass capacity and the allowable moment of inertia defined in this section, are dynamic limit values determined by the capacity of the motor that drives axes or the capacity of the speed reducer. Therefore, it does not guarantee the accuracy on all areas of tooling. Guaranteed accuracy is measured from the center point of the mechanical interface surface. Please note that if the point of operation is kept away from the mechanical interface surface by long and low-rigid tooling, the positioning accuracy may deteriorate or may cause vibration.

Note that the allowable offset value (Z direction) from the lower edge of the shaft to the position of center of gravity is 100 mm.

[Caution] Even within the allowable range previously mentioned, an overload alarm may be generated if an ascending operation continues at a micro-low speed. In such a case, it is necessary to increase the ascending speed.

[Caution] This robot will restrict speed automatically by internal controls when the load center-of-gravity position separates from the shaft center. Refer to [Page 15, "2.2.3 Relationships Among Mass Capacity, Speed, and Acceleration/Deceleration Speed"](#) in detail.

The allowance distance (allowance offset amount) from the center of the shaft to the gravity center of loading weight is 100mm.

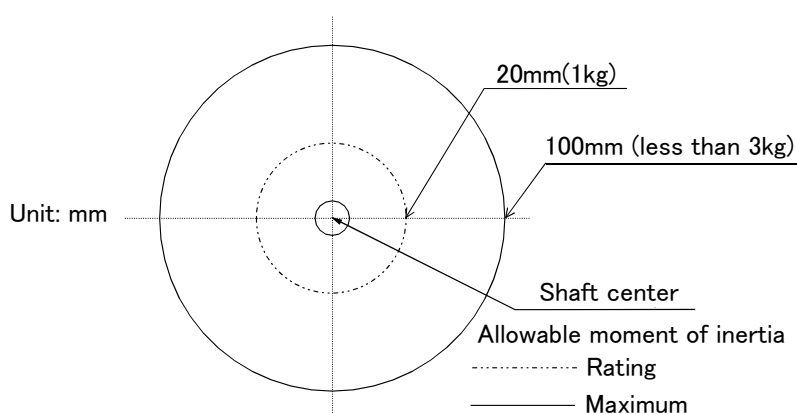

Fig.2-1 : Position of center of gravity for loads (for loads with comparatively small volume)

### 2.2.3 Relationships Among Mass Capacity, Speed, and Acceleration/Deceleration Speed

This robot automatically sets the optimum acceleration and deceleration speeds and maximum speed, according to the load capacity and size that have been set, and operates using these automatically set speeds.

To achieve that, it is necessary to correctly set the actual load data (mass and size of hand and work) to be used. However, vibration, overheating and errors such as excessive margin of error and overload may occur, depending on the robot operation pattern or ambient temperature.

In this case, reduce the speed and the acceleration and deceleration rate before continuing to use. This is done by accessing the robot program and adjusting the speed settings (Ovrd) and the acceleration and deceleration settings (Accel).

If a setting is performed in such a way that it falls below the mounted load, the life span of the mechanism elements used in the robot may be shortened. In the case of a work requiring a high degree of accuracy, set up the load correctly and use the robot by lowering the ratios of the acceleration and deceleration speeds.

#### (1) Setting Load Capacity and Size (Hand Conditions)

Set up the capacity and size of the hand with the "HNDDAT\*" parameter (optimum acceleration/deceleration setting parameter), and set up the capacity and size of the work with the "WRKDAT\*" parameter. Numbers 0 to 8 can be used for the asterisk (\*) part. Designate the "HNDDAT\*" and "WRKDAT\*" parameters to be used using the "LoadSet" command in a program.

For more details, refer to the separate "Instruction Manual/Detailed Explanation of Functions and Operations." It is the same meaning as "LoadSet 0.0" if not using the "LoadSet".

<Factor default settings>

	Hand mass kg	size X mm	size Y mm	size Z mm	center-of-gravity position X mm	center-of-gravity position Y mm	center-of-gravity position Z mm
HNDDAT*	3.0	99.0	99.0	76.0	0.0	0.0	38.0
WRKDAT*	0.0	0.0	0.0	0.0	0.0	0.0	0.0

Note) The position of the center of gravity is located at the center of the surface at the bottom of the shaft. Set the X, Y and Z center of gravity positions for the tool coordinate directions (the Z center of gravity position will be a plus for downward directions).

### 2.2.4 Vibrations at the Tip of the Arm during Low-Speed Operation of the Robot

Vibrations at the tip of the arm may increase substantially during the low-speed operation of the robot, depending on the combination of robot operation, hand mass and hand inertia. This problem occurs when the vibration count specific to the robot arm and the vibration count of the arm driving force are coming close to each other. These vibrations at the tip of the arm can be reduced by taking the following measures:

- 1) Change the robot's operating speed by using the Ovrd command.
- 2) Change and move the teaching points of the robot.
- 3) Change the hand mass and hand inertia.

## 2.2.5 Vibration of shaft (J3 axis) position and arm end

Vibrations at the tip of the arm may increase substantially during operation under the shaft position near the low end or the high end of the robot, depending on the combination of hand mass and hand inertia. This problem occurs according to that inertia, because the distance from the shaft support section to the shaft end becomes long. When this vibration affects the robot's operations, please change operating speed etc. like the above [Page 15, "2.2.4 Vibrations at the Tip of the Arm during Low-Speed Operation of the Robot"](#).

### (1) Relationship Between Mass Capacity and Speed

A function to optimize the maximum speed of each axis according to the setting value of the load capacity will be activated (Refer to [Fig. 2-2](#)).

However, this function does not work with the setting of 1kg or lighter load mass. When the setting of the load mass is changed to 1kg or heavier, the maximum speed is compensated according to the load mass.

[CAUTION] Depending on the operation pattern, the speed and/or acceleration/deceleration at the front edge may not be parallel with the speed and the rate of change of acceleration/deceleration specified in a program.

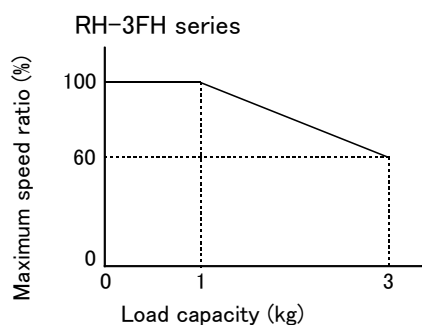

Fig.2-2 : Automatic compensation of speed

(2) Relationship Between Height of Shaft (J3 Axis) and Acceleration/Deceleration Speed

A function to optimize the acceleration/deceleration speed according to the height of the shaft (Refer to Fig. 2-3, Fig. 2-4) will be activated. This function is invalid if the shaft (axis J3) operates at a position above P3 in Fig. 2-3. Acceleration/deceleration is compensated for at a position below P3 in Fig. 2-3 if the position of the center of gravity of the load is located at the front edge of the shaft.

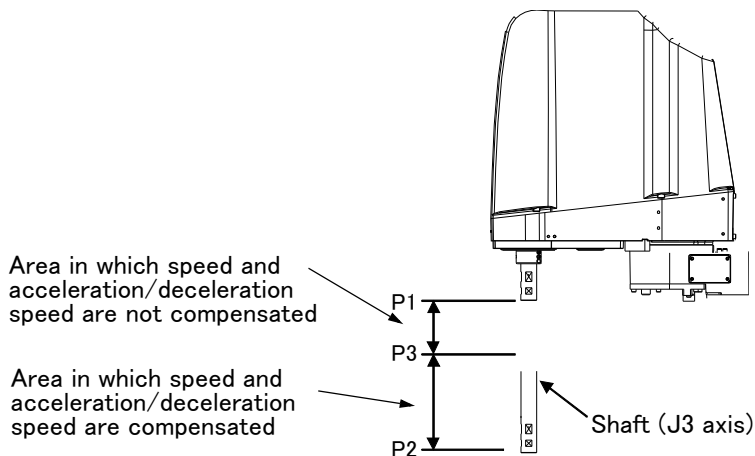

Fig.2-3 : Area in which acceleration/deceleration speed is compensated

Table 2-4 : Area in which acceleration/deceleration speed is compensated

Stroke length	J3 axis stroke (mm)		Compensation area (P2 to P3)
	P1 (Upper end)	P2 (Lower end)	
120	340	220	220 ~ 310
150	370	220	220 ~ 310

J3 axis (Z) stroke 120mm/150mm  
(Standard Acceleration/deceleration speed)

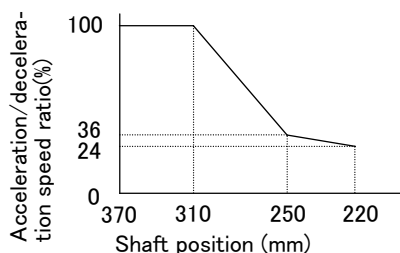

Fig.2-4 : Automatic compensation of acceleration/deceleration speed

(3) Relation between offset length and the maximum speed

A function to optimize the maximum speed of each axis according to the offset length will be activated. (Refer to Fig. 2-5)

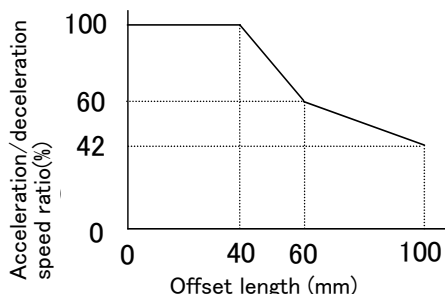

Fig.2-5 : Relationship of the offset length and maximum velocity

[Supplementary explanation 1]: The setting which shortens execution time

The execution time can be improved by using the following methods.

- 1) Perform continuous path operation using the Cnt command.
- 2) Control the optimum acceleration/deceleration using the Oadl command.
- 3) Control the optimum speed using the Spd command.
- 4) Setting a larger value in the optimum acceleration/deceleration adjustment rate parameter: JADL. (Maximum 100)

The moving time can be shortened by setting a larger value in the optimum acceleration/deceleration adjustment rate parameter (JADL). In this robot, the acceleration/deceleration speed is initialized to allow continuous moving with a short wait time (setting of B in the Fig. 2-6).

This setting is suited for continuous operations that have a short tact time, such as palletizing work.

Conversely, if quick moves (short moving time) are required, such as L/UL work on machined parts, the acceleration/deceleration speed can be increased by initial setting (setting of A in the Fig. 2-6).

However, please note that some setting values of acceleration/deceleration speed tend to cause overload and overheat errors. In such a case, extend the wait time, reduce the acceleration/deceleration speed, or decrease the moving speed.

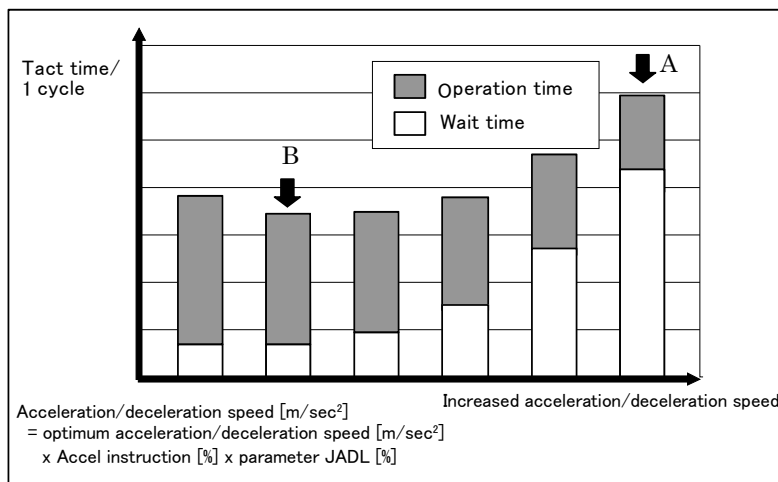

Fig.2-6 : Relationship between Acceleration/deceleration Speed and Tact Time (Conceptual Drawing)

(4) Time to reach the position repeatability

When using this robot, the time to reach the position repeatability may be prolonged due to the effect of residual vibration at the time of stopping. If this happens, take the following measures:

- 1) Change the operation position of the Z axis to the location near the top as much as possible.
- 2) Increase the operation speed prior to stopping.
- 3) When positioning the work near the bottom edge of the Z axis, if no effectiveness is achieved in step "2" above, perform operation ① (robot path: O → A → C). In the case of operation ② (robot path: O → B → C), residual vibration may occur. (Refer to Fig. 2-7.)

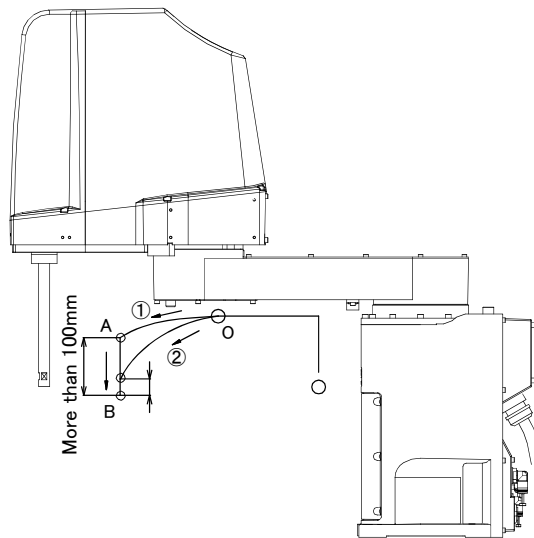

Fig.2-7 : Recommended path when positioning at the bottom edge of the Z axis

2.2.6 Collision detection

This series have the "collision detection function" which detects the abnormalities by the collision of the robot arm, and the initial setting has set this function as the enable to suppress damage to the minimum.

Although the enable/disable of this function can be changed by parameter: COL and command: ColChk, you should use in valid condition of this function for protection of the robot and of the peripheral equipment.

The abnormalities are detected by the robot's kinetics model, presuming torque necessary for movement at any time. Therefore, the setting parameter (HNDDAT\*, WRKDAT\*) of the hand and the work piece conditions should be right. And, it may be detected as the collision in movement as speed and motor torque are changed rapidly. (for example, the movement near the place of the origin by linear interpolation, the reversal movement, the cold condition, the operation after long term stoppage)

In such a case, by adjusting the value of the setting parameter (COLLVL, COLLVLJG) of the collision detection level according to actual use environment, the sensitivity of collision detection can be optimized and the damage risk can be reduced further. And, in the operation after the low temperature or long term stoppage, please operate by accustoming at low speed (warm-up), or use the warm-up operation mode.

Refer to the separate instruction manual "Detailed explanations of functions and operations" for details of related parameter.

Table 2-5 : Factory-shipments condition

	JOG operation	Automatic
RH-3FH series	Valid	Invalid



## 2.2.7 Protection specifications

### (1) Types of protection specifications

The robot arm has protection specifications that comply with the IEC Standards. The protection specifications and applicable fields are shown in [Table 2-6](#).

Table 2-6 : Protection specifications and applicable fields

Type	Protection specifications (IEC Standards value)	Classification	Applicable field	Remarks
RH-3FHxx15	Robot arm: IP20	General-purpose environment specifications	General assembly Slightly dusty environment	

The IEC IP symbols define the degree of protection against solids and fluids, and do not indicate a protective structure against the entry of oil.

The IEC standard is described by the following "Information" And, the corrosion of the rust etc. may occur to the robot with the liquids.

#### 【Information】

##### • The IEC IP20

It indicates the protective structure that prevents an iron ball  $12^{+0.05}_0$  mm diameter, which is being pressed with the power of  $3.1 \text{ kg} \pm 10\%$ , from going through the opening in the outer sheath of the supplied equipment.

## 2.2.8 Clean specifications

### (1) Types of clean specifications

The robot arm with clean specification is made by order. Please check the delivery schedule.

Table 2-7 : Clean specifications

Type	Degree of cleanliness	Internal suction	Remarks
RH-3FHxx12C	ISO class 3 <sup>Note1)</sup>	<ul style="list-style-type: none"> <li>• Suck the inside of robot arm with vacuum pump. (prepared by customer)</li> <li>• Use it in the clean room with the down flow (flow velocity 0.3 m/s above).</li> </ul>	The use of a vacuum generating valve is recommended.

Note1) The conditions necessary to guarantee cleanliness are as follows: clean room down flow greater than 0.3 m/s, robot internal suction of 30 to 50 L/min, and installation of an exhaust duct at the rear of the robot's main base. A  $\phi 8$  joint has been prepared at the rear of the base for suction.

#### ■ Precautions for use

- 1) A  $\phi 8$  VACUUM coupling is provided in the base section of the robot arm for vacuum inside the robot arm. (Refer to [Fig. 2-23](#)) When using the robot, connect this coupling with the vacuum generating valve (Refer to [Table 2-8](#)) and vacuum pump (furnished by the customer).
- 2) To suck in the robot arm, use the vacuum generator of the specification shown in following a) and b).
  - a) When using the vacuum generator

Table 2-8 : Specifications of vacuum generation valve (Confirmed in our company)

Type	Maker	Air pressure <sup>Note1)</sup>	Quantity
MEDT 14	KOGANEI CORPORATION	• Vacuum rate: 90.0 L/min(ANR)	1

Note1) It is the vacuum pump maker's written specification.

##### b) When using the vacuum pump

Assure the vacuum flow rate of 30-50L/min. And, secure the exhaust course from the pump not to affect the power supply and the cleanness for the vacuum pumps.

3) The ventilation duct is attached to the robot arm rear (refer to Fig. 2-8). As the Z axis moves up and down the volume of the bellows varies, and air is sucked in and released out of the robot's ventilation duct opening. Be sure to locate the ventilation duct's opening in a position that will not affect the robot's cleanliness.

Furthermore, whilst it is only a small amount, internal suction results in external air flows into the robot through the ventilation duct's opening, and therefore the following two points should be considered when deciding where to locate the ventilation duct's opening.

- The opening should be facing downwards
- The opening should not be located in the vicinity of dust/dirt or liquids, etc.  
(Recommended cleanliness of surrounding area: less than ISO class 5)

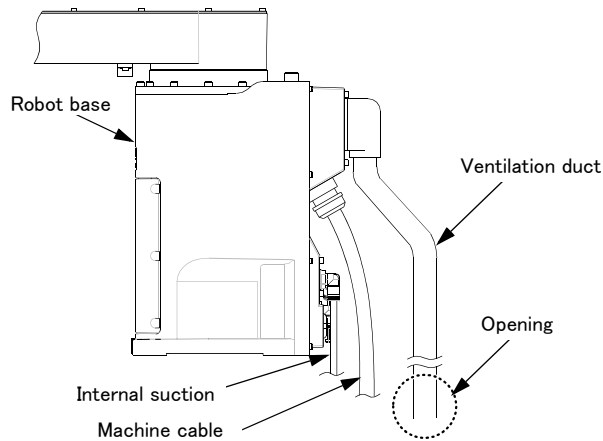

Fig.2-8 : Installation of Ventilation Duct

4) When using the optional electromagnetic valve set, we recommend using the primary piping's spare piping ( $\phi 6$  air hose) to release the exhaust fumes.

Please take care as leaking exhaust fumes inside the robot may have an impact on the robot's cleanliness.

2.3 Names of each part of the robot



Fig.2-9 : Names of each part of the robot

2.4 Outside dimensions • Operating range diagram

2.4.1 Outside dimensions • Operating range diagram

(1) Standard Specification

**Note**

- \*1) Indicates the space necessary to replace the battery.
- \*2) Indicates screw holes (M4 depth 6mm) for fixing user wiring/piping. Six places on both-sides of No.2 arm, Two places on front surface.
- \*3) The distance to a minimum bendable radius of the machine cable for CR750/751 controller.
- \*4) Indicates the space necessary to connect the machine cable for CR750/751 controller.

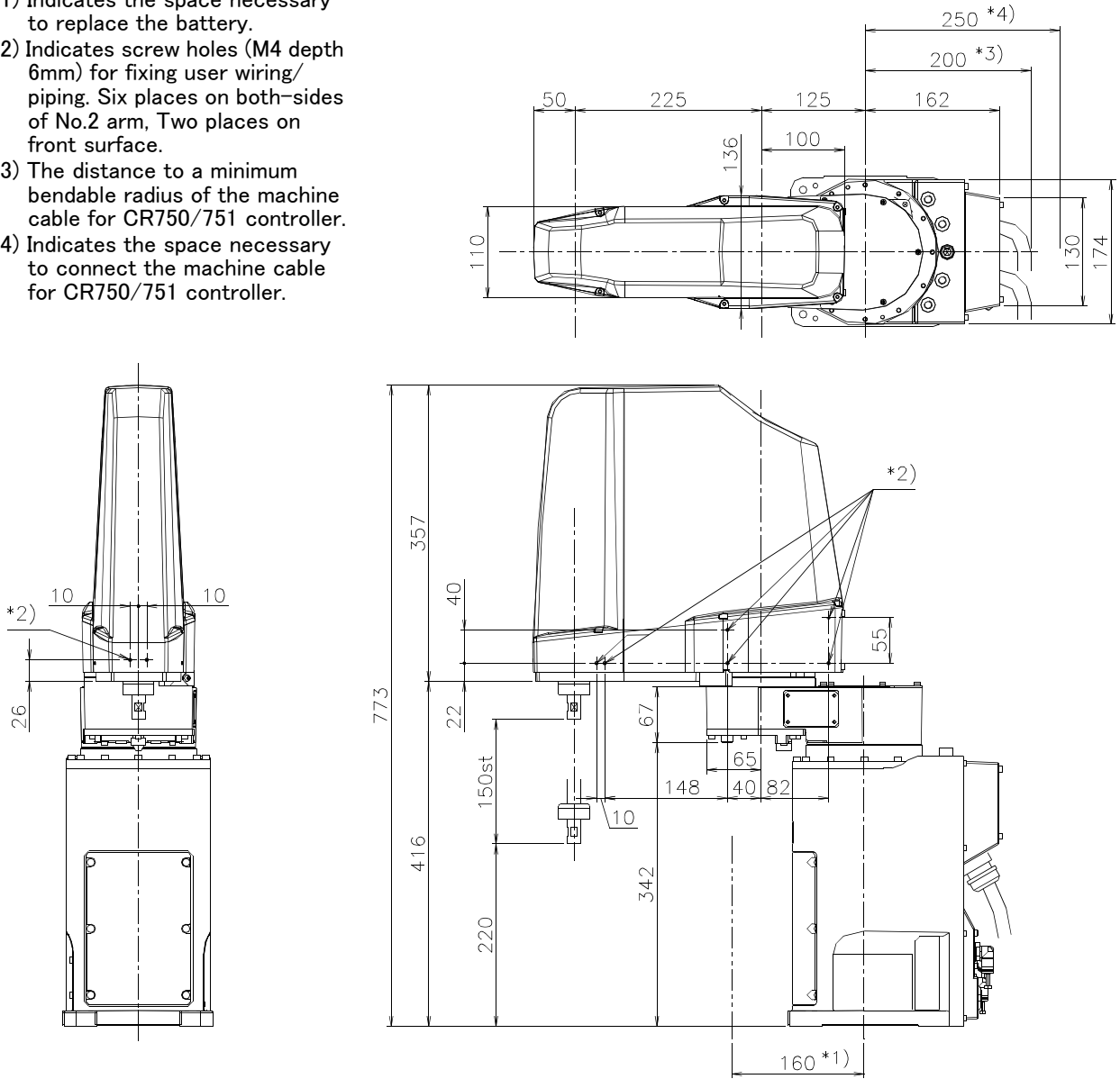

Note) The drawing shows an example of the CR751 controller connection robot.

Note) Refer to Fig. 2-22 for the mechanical interface section and installation base section dimensions.

Fig.2-10 : Outside dimensions of RH-3FH3515



**Note**

- \*1) Indicates the space necessary to replace the battery.
- \*2) Indicates screw holes (M4 depth 6mm) for fixing user wiring/piping. Six places on both-sides of No.2 arm, Two places on front surface.
- \*3) The distance to a minimum bendable radius of the machine cable for CR750/751 controller.
- \*4) Indicates the space necessary to connect the machine cable for CR750/751 controller.

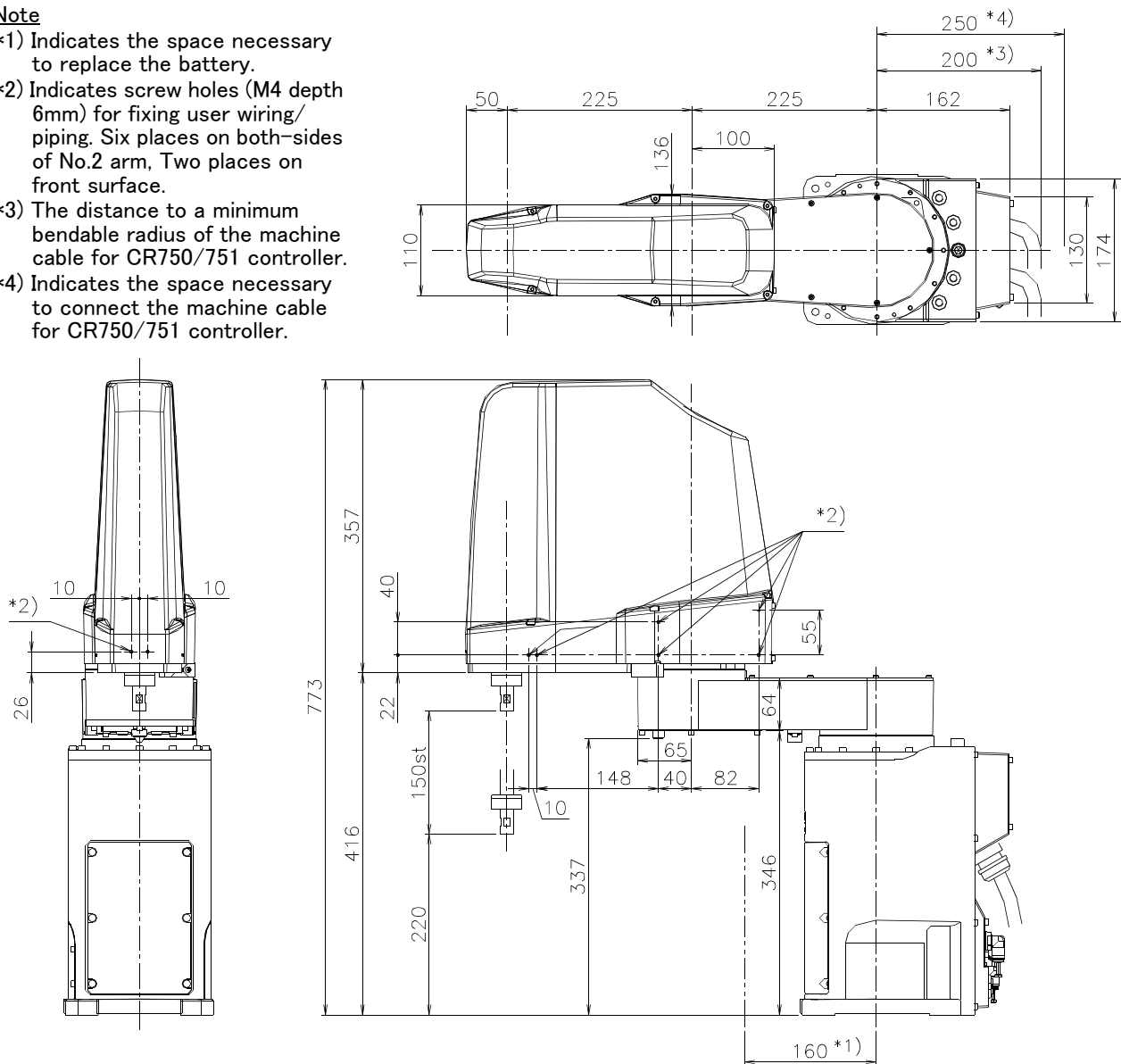

Note) The drawing shows an example of the CR751 controller connection robot.

Note) Refer to Fig. 2-22 for the mechanical interface section and installation base section dimensions.

Fig.2-12 : Outside dimensions of RH-3FH4515

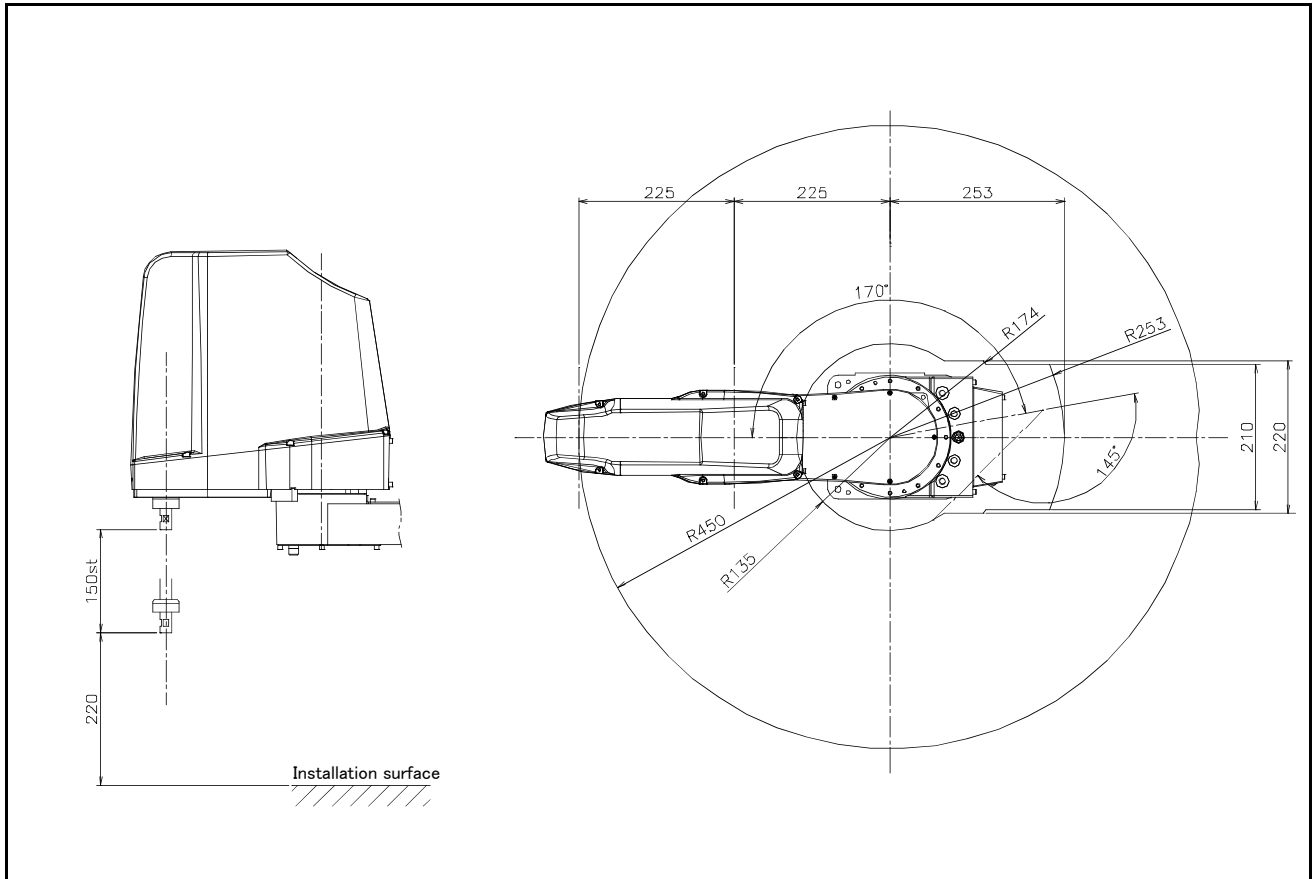
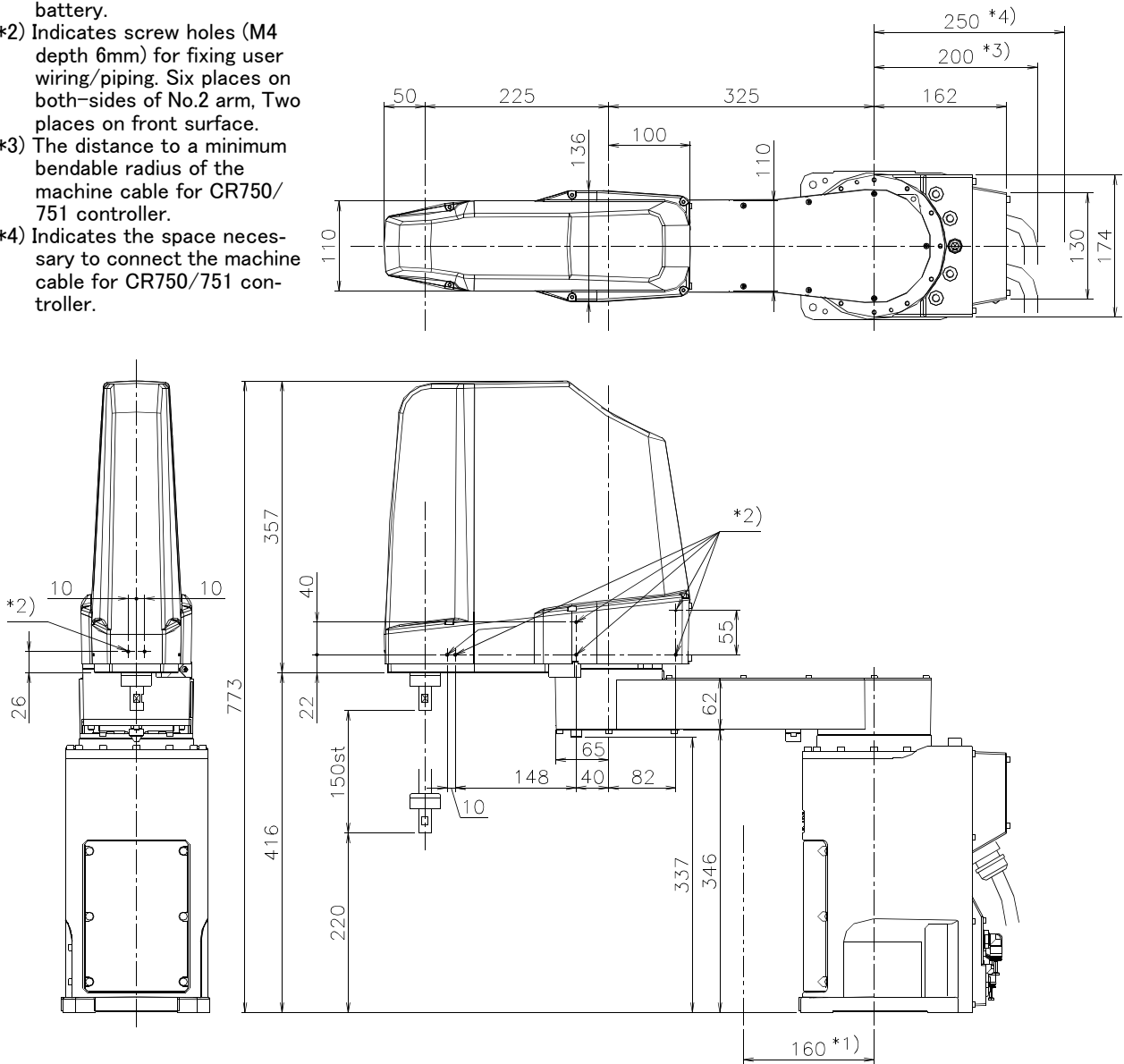

Fig.2-13 : Operating range diagram of RH-3FH4515

**Note**

- \*1) Indicates the space necessary to replace the battery.
- \*2) Indicates screw holes (M4 depth 6mm) for fixing user wiring/piping. Six places on both-sides of No.2 arm, Two places on front surface.
- \*3) The distance to a minimum bendable radius of the machine cable for CR750/751 controller.
- \*4) Indicates the space necessary to connect the machine cable for CR750/751 controller.



Note) The drawing shows an example of the CR751 controller connection robot.

Note) Refer to Fig. 2-22 for the mechanical interface section and installation base section dimensions.

Fig.2-14 : Outside dimensions of RH-3FH5515



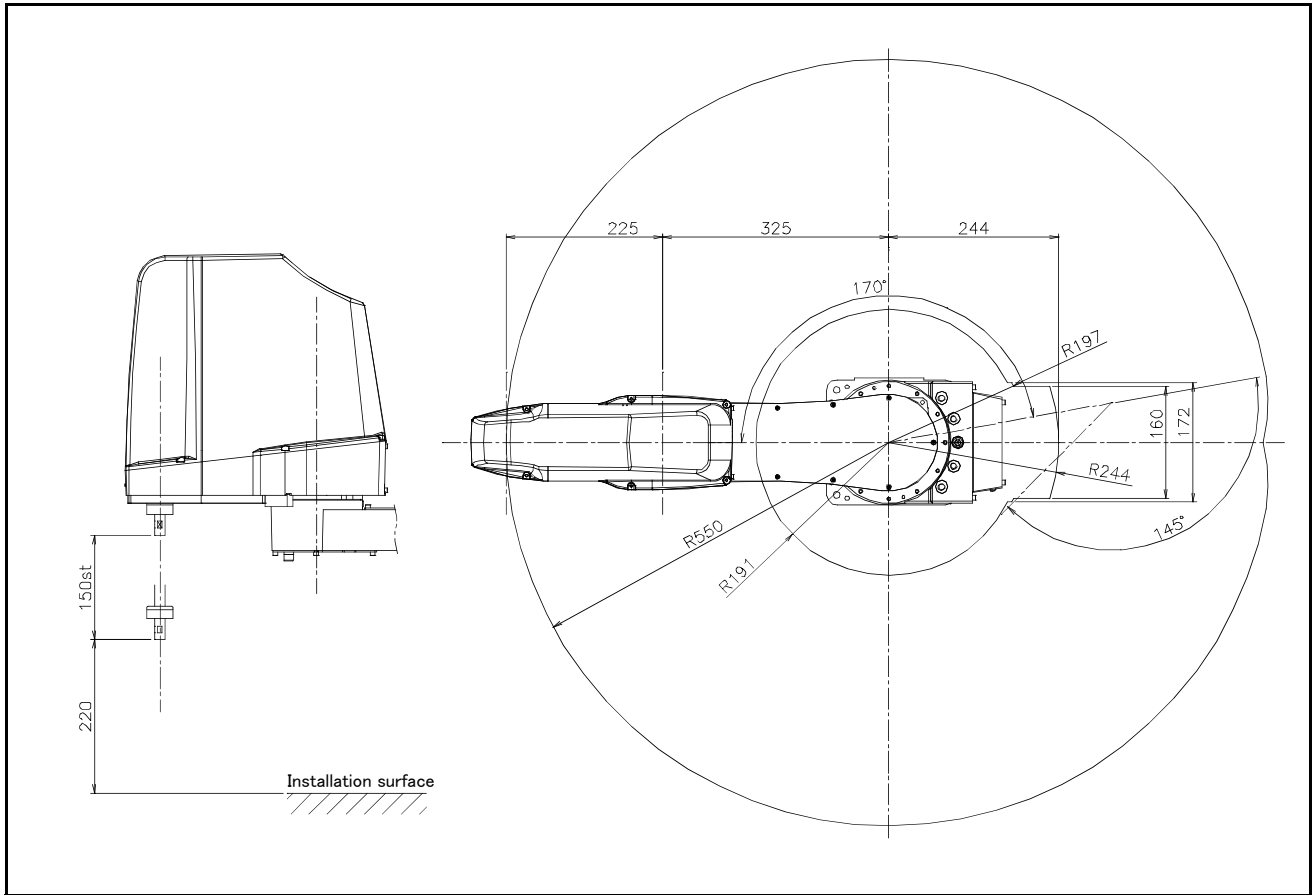
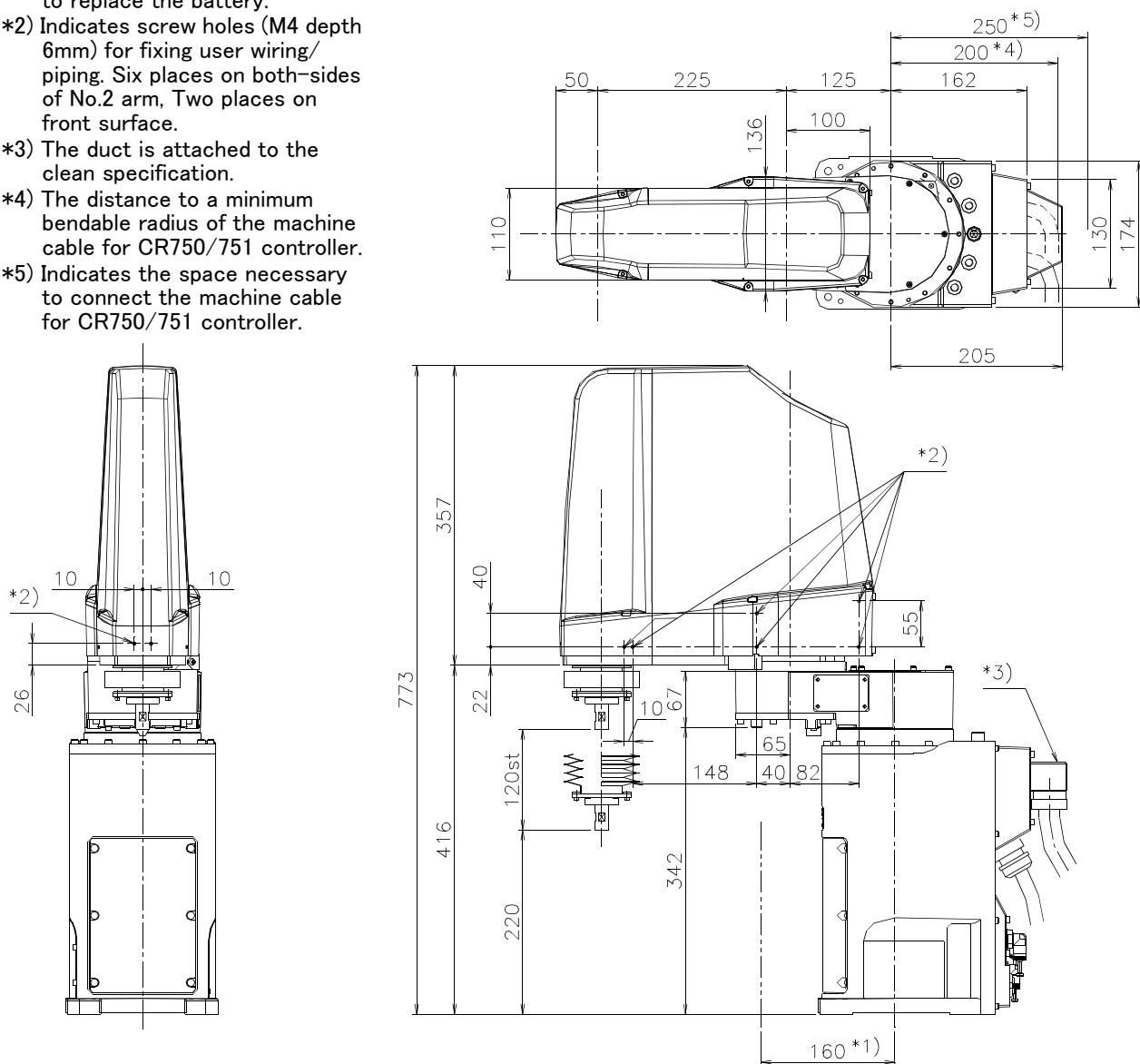

Fig.2-15 : Operating range diagram of RH-3FH5515

(2) Clean Specification

**Note**

- \*1) Indicates the space necessary to replace the battery.
- \*2) Indicates screw holes (M4 depth 6mm) for fixing user wiring/piping. Six places on both-sides of No.2 arm, Two places on front surface.
- \*3) The duct is attached to the clean specification.
- \*4) The distance to a minimum bendable radius of the machine cable for CR750/751 controller.
- \*5) Indicates the space necessary to connect the machine cable for CR750/751 controller.



Note) The drawing shows an example of the CR751 controller connection robot.

Note) Refer to Fig. 2-22 for the mechanical interface section and installation base section dimensions.

Fig.2-16 : Outside dimensions of RH-3FH3512C

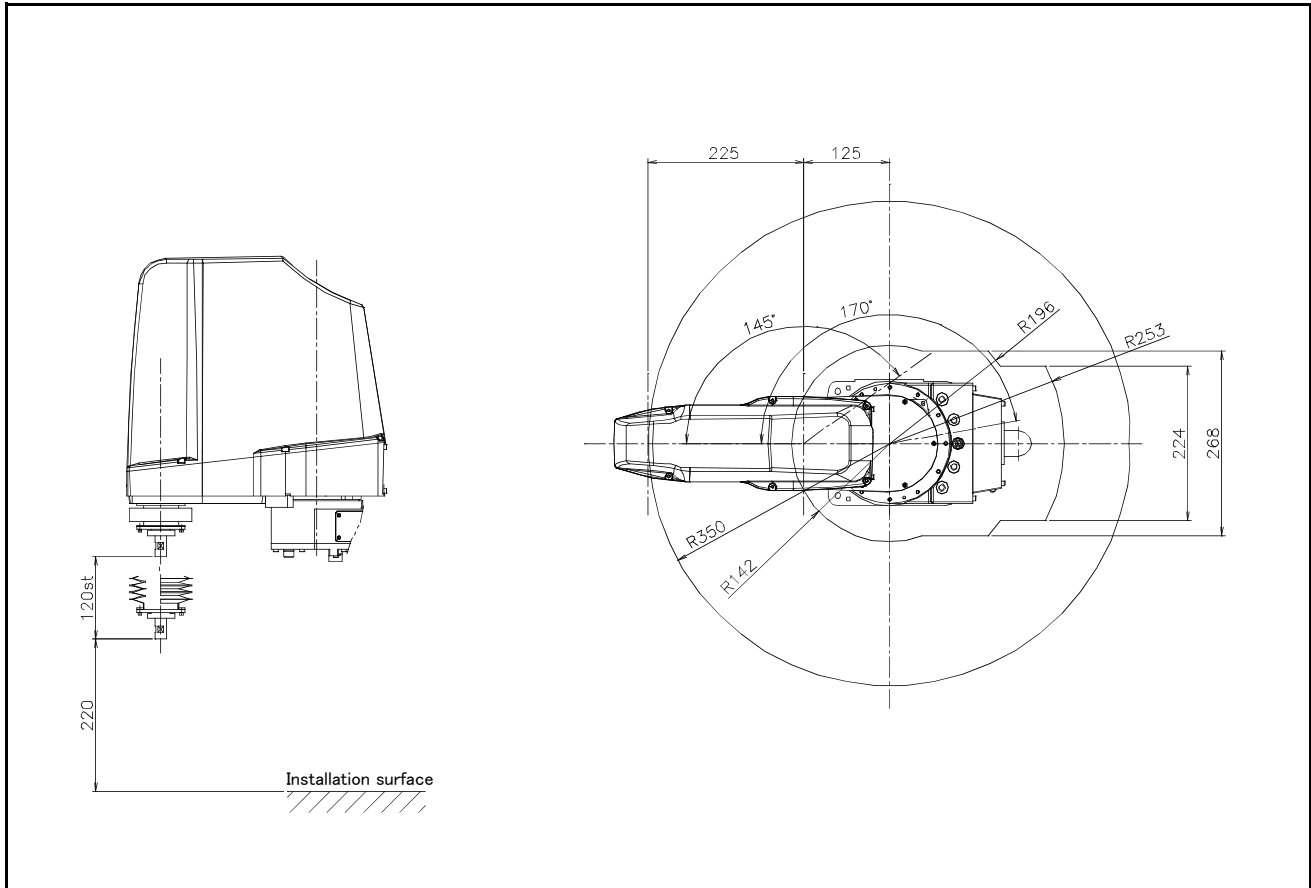
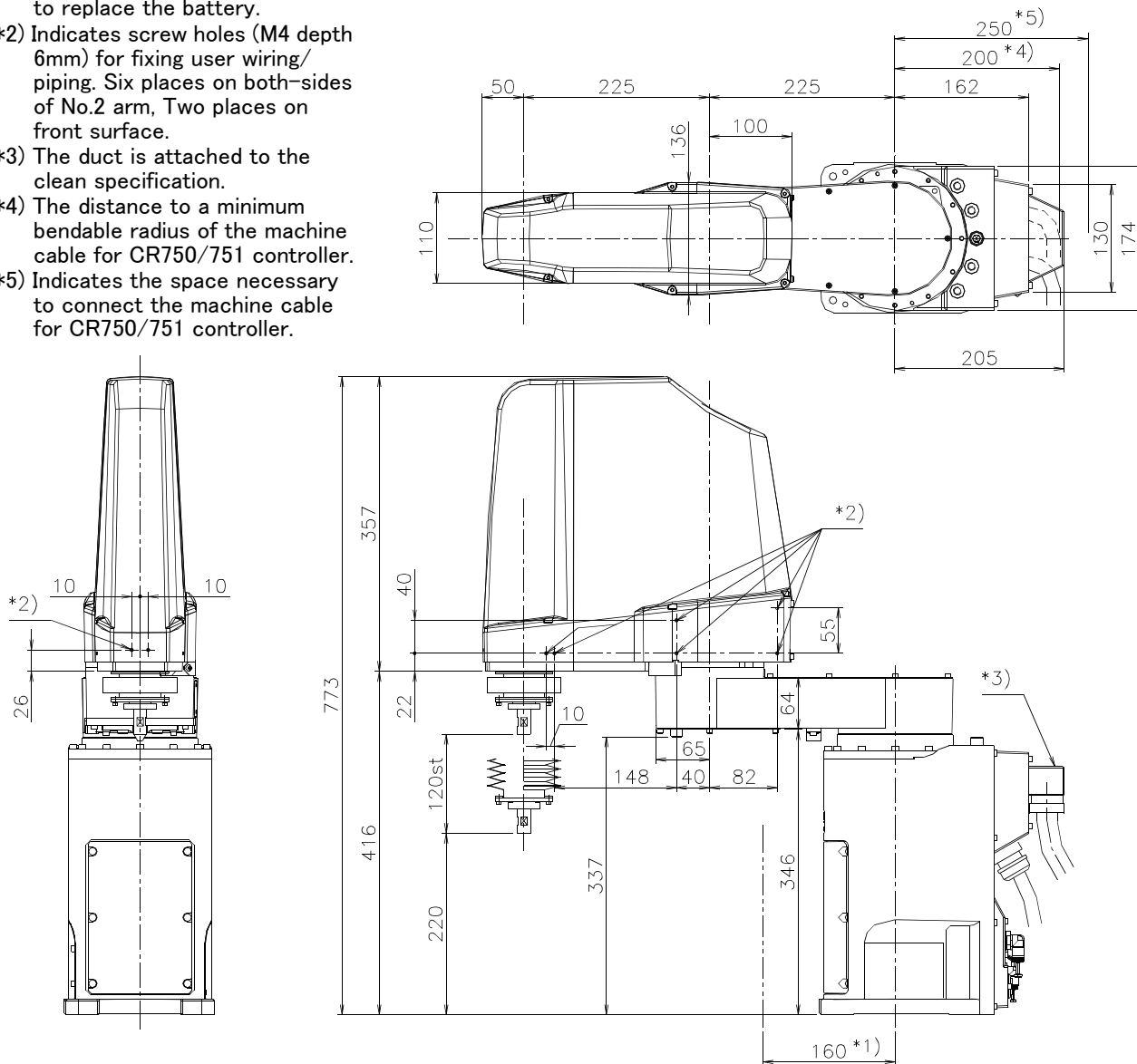

Fig.2-17 : Operating range diagram of RH-3FH3512C

**Note**

- \*1) Indicates the space necessary to replace the battery.
- \*2) Indicates screw holes (M4 depth 6mm) for fixing user wiring/piping. Six places on both-sides of No.2 arm. Two places on front surface.
- \*3) The duct is attached to the clean specification.
- \*4) The distance to a minimum bendable radius of the machine cable for CR750/751 controller.
- \*5) Indicates the space necessary to connect the machine cable for CR750/751 controller.



Note) The drawing shows an example of the CR751 controller connection robot.

Note) Refer to Fig. 2-22 for the mechanical interface section and installation base section dimensions.

Fig.2-18 : Outside dimensions of RH-3FH4512C

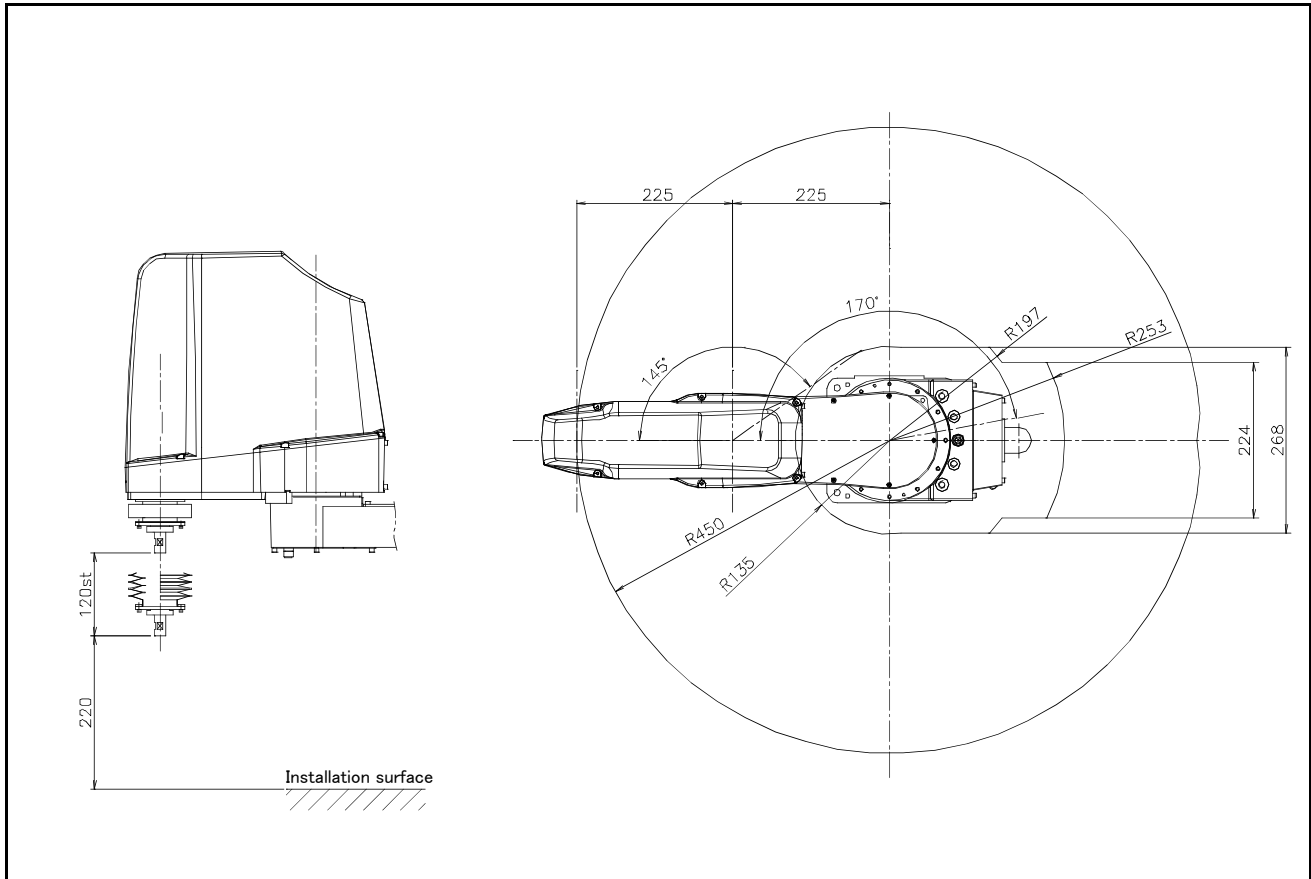
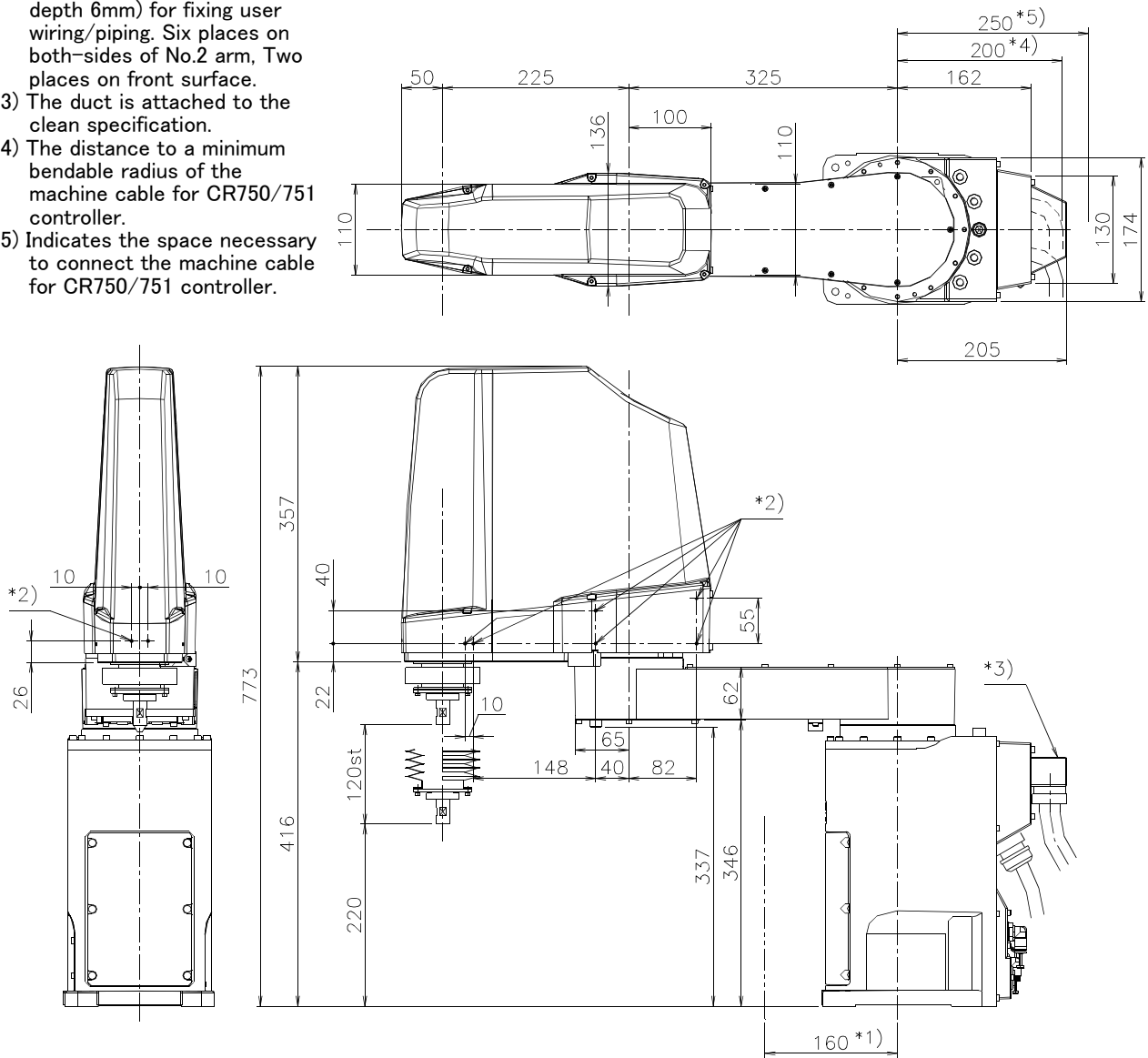

Fig.2-19 : Operating range diagram of RH-3FH4512C

**Note**

- \*1) Indicates the space necessary to replace the battery.
- \*2) Indicates screw holes (M4 depth 6mm) for fixing user wiring/piping. Six places on both-sides of No.2 arm. Two places on front surface.
- \*3) The duct is attached to the clean specification.
- \*4) The distance to a minimum bendable radius of the machine cable for CR750/751 controller.
- \*5) Indicates the space necessary to connect the machine cable for CR750/751 controller.



Note) The drawing shows an example of the CR751 controller connection robot.

Note) Refer to Fig. 2-22 for the mechanical interface section and installation base section dimensions.

Fig.2-20 : Outside dimensions of RH-3FH5512C

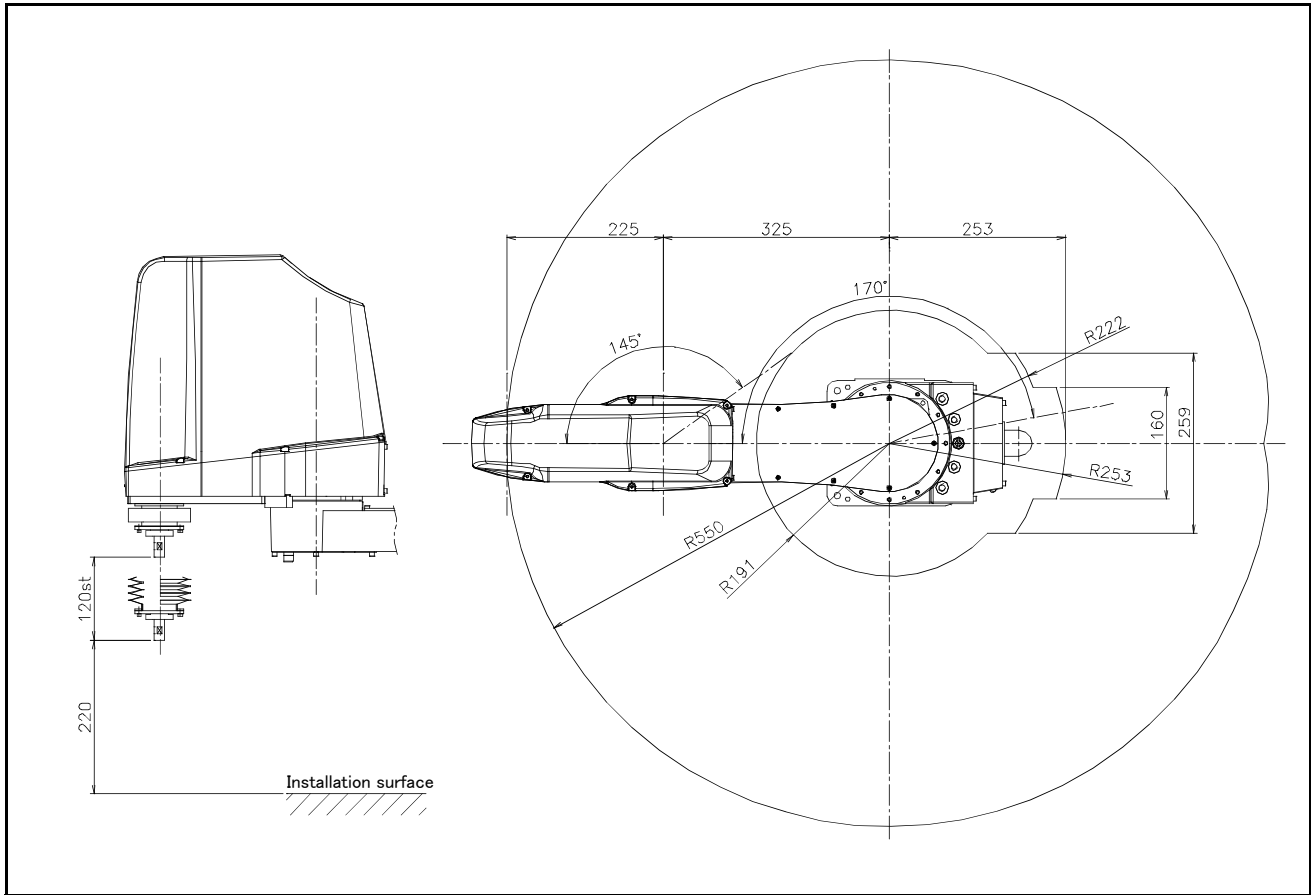

Fig.2-21 : Operating range diagram of RH-3FH5512C

2.4.2 Mechanical interface and Installation surface

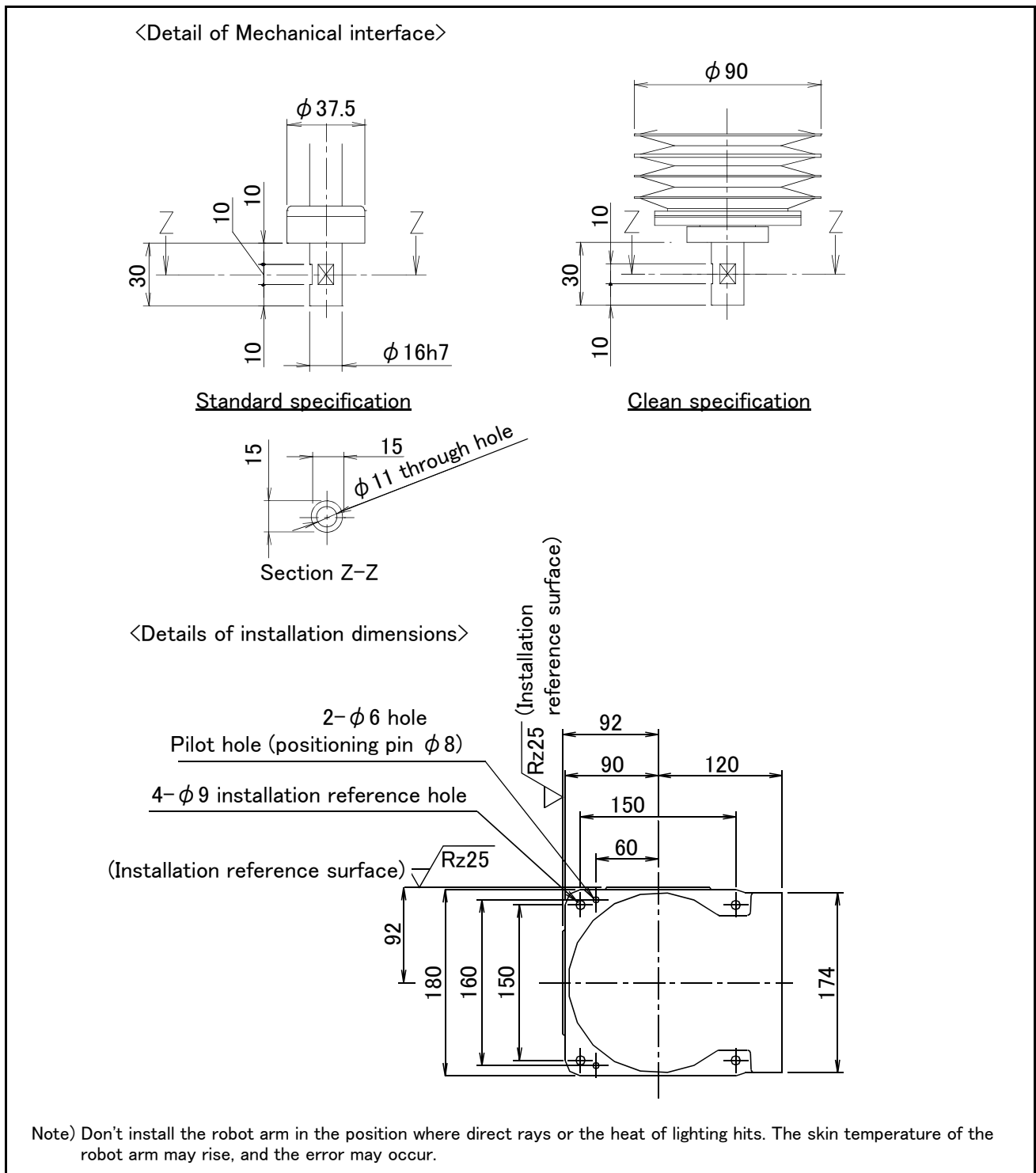

Fig.2-22 : Mechanical interface and Installation surface



### 2.4.3 Outside dimensions of machine cables

#### (1) Connection with the CR750 controller

##### 1) Power cable

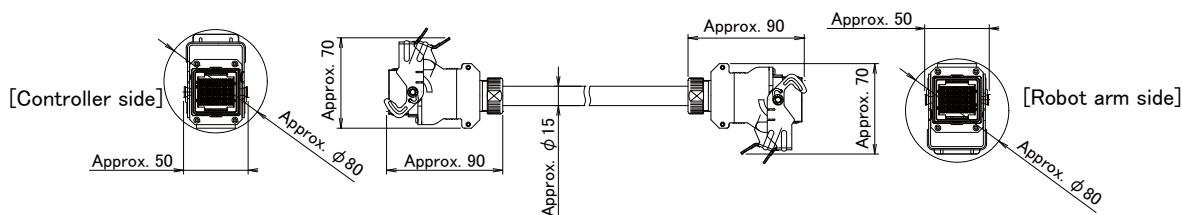

Note) If using an optional machine cable extension, refer to Page 48, "(1) Machine cable extension" in a diameter of the cable.

##### 2) Signal cable

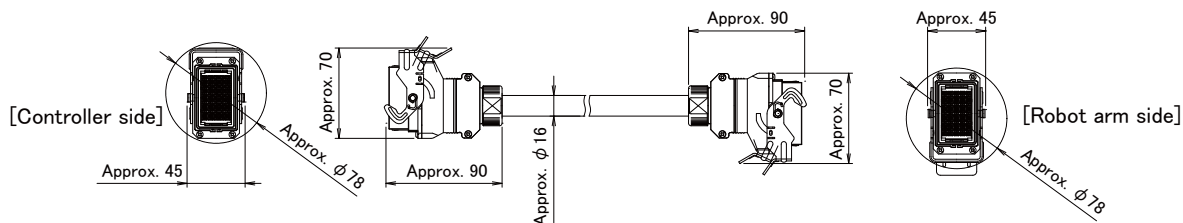

Note) If using an optional machine cable extension, refer to Page 48, "(1) Machine cable extension" in a diameter of the cable.

#### (2) Connection with the CR751 controller

##### 1) Power cable

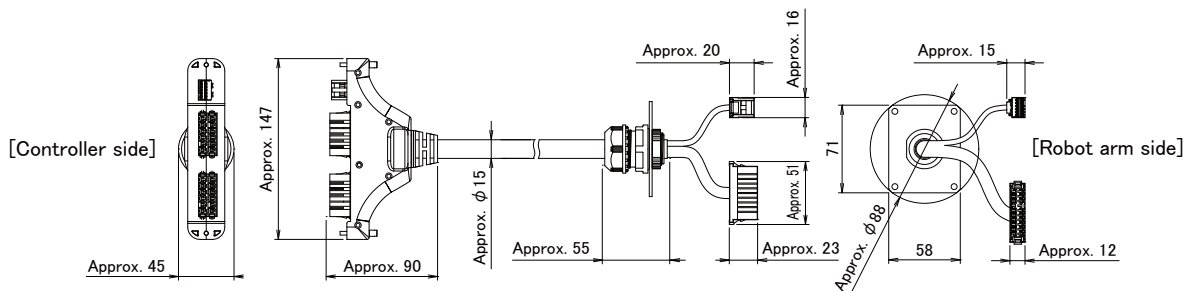

Note) If using an optional machine cable extension, refer to Page 48, "(1) Machine cable extension" in a diameter of the cable.

##### 2) Signal cable

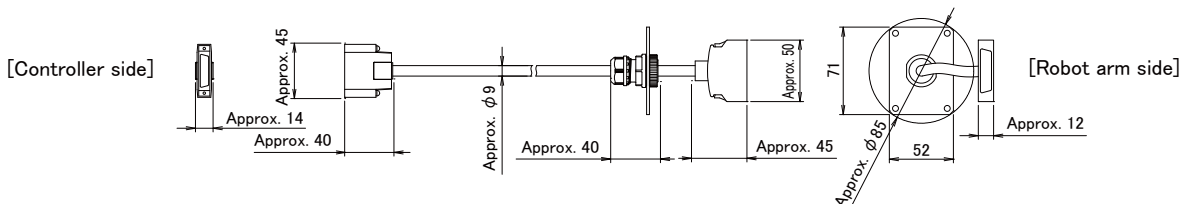

Note) If using an optional machine cable extension, refer to Page 48, "(1) Machine cable extension" in a diameter of the cable.

## 2.5 Tooling

### 2.5.1 Wiring and piping for hand

Shows the wiring and piping configuration for a standard-equipped hand.

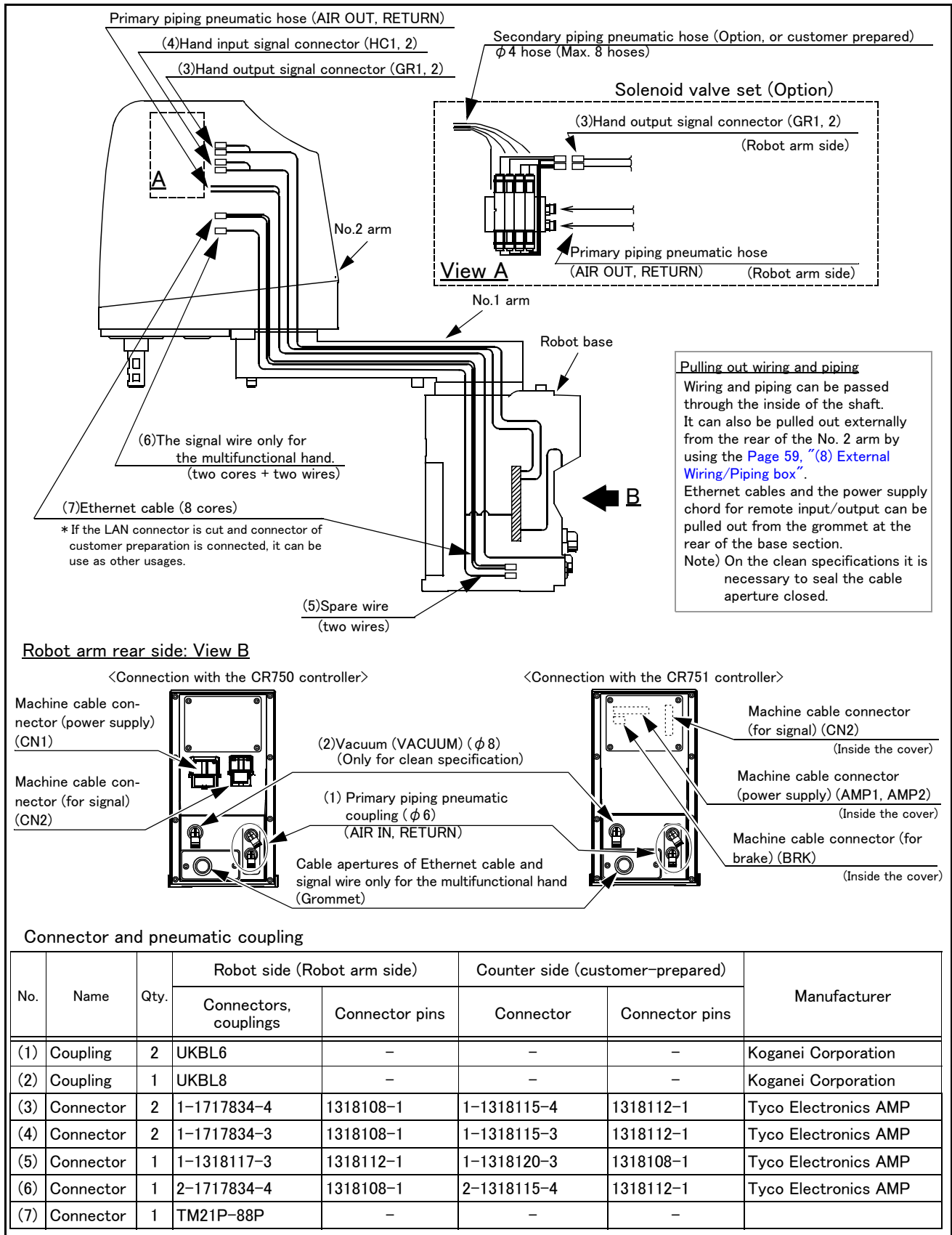

Fig.2-23 : Wiring and piping for hand

## 2.5.2 Internal air piping

### (1) Standard type

- 1) The robot has two  $\phi 6$  urethane hoses from the pneumatic entrance on the base section to the No.2 arm. One hose is the primary piping for the pneumatic equipment, and the other pipe is used for air exhaust.
- 2) The pneumatic inlet in the base section has a  $\phi 6$  pneumatic coupling bridge.
- 3) The solenoid valve set (optional) can be installed to the side on No.2 arm.
- 4) Refer to [Page 53, "\(3\) Solenoid valve set"](#) for details on the electronic valve set (optional).

### (2) Clean type

- 1) The primary piping is the same piping as the standard type.
- 2) With the clean specification, a  $\phi 8$  coupling is provided in the base section for suction inside the machine. For use, connect it to the suction port of the vacuum pump or the coupling on the "VACUUM" side of the vacuum generating valve. Moreover, to clean the exhaust from the vacuum pump or vacuum generator, use the exhaust filter (prepared by the customer).
- 3) Refer to [Page 20, "2.2.8 Clean specifications"](#) for details of the vacuum for suction.
- 4) Supply clean air to the vacuum generator.

## 2.5.3 Internal wiring for the hand output cable

- 1) The hand output primary cable extends from the connector PCB of the base section to the back side of the No.2 arm. (AWG#24(0.2mm<sup>2</sup>): 10 cables) The cable terminals have connector bridges for eight hand outputs. The connector names are GR1 and GR2. To pull the wiring out of the arm, following separate options are required.
  - Hand output cable ..... 1F-GR60S-01
  - External wiring and piping box ..... 1F-UT-BOX

## 2.5.4 Internal wiring for the hand input cable

- 1) The hand input cable extends from the connector PCB of the base section to the No.2 arm. (AWG#24(0.2mm<sup>2</sup>): 10 cables) The cable terminals have connector bridges for eight hand inputs. The connector names are HC1 and HC2.
- 2) The hand check signal of the pneumatic hand is input by connecting this connector. To extend the wiring to the outside of the arm, following separate options are required.
  - Hand input cable ..... 1F-HC35C-01
  - External wiring and piping box ..... 1F-UT-BOX

## 2.5.5 Ethernet cable

Ethernet cables are installed from the robot's base section up to the No. 2 arm section, and can be used. Similar to on our previous models, these cables can also be used for backup wiring. For further details please refer to the separate "Instruction Manual/Robot Arm Setup".

Example of use for backup wiring.

- When connecting previously used tools to the robot
- Folding back the hand output cable when attaching the electromagnetic valve to the robot's exterior.
- When attaching 8 devices or more to the hand section such as sensors, (8 input and 8 output dedicated points are available for hand signals.). In this case connect the signals (of the sensors, etc.) to parallel input/output signals.

When shipped from the factory, both ends are LAN connectors.

When using it as backup wiring, cut the LAN connectors off and use with user supplied connectors.

When using it as backup wiring for data communication, the shield wire must be grounded. If the shield wire is not grounded, it may cause a communication abnormality by noise superposed on the cable.

Table 2-9 : Ethernet cable specification

Item	Specification
Communication speed	100BASE-TX
Size	AWG #26 (0.13mm <sup>2</sup> ) x four pair (total eight cores)
Externality of insulator	Approx. 0.98 mm

### 2.5.6 About the Installation of Tooling Wiring and Piping (Examples of Wiring and Piping)

The customer is required to provide tooling wiring, piping and metal fixtures.

Screw holes are provided on the robot arm for the installation of tooling wiring, piping and metal fixtures. (Refer to the Fig. 2-24.)

The length of wiring and piping and the installation position on the robot must be adjusted according to the work to be done by the robot. Please use the following example as reference.

#### <Precautions>

- A hand input cable and a hand curl cable are available as optional accessories for your convenience.
- After performing wiring and piping to the robot, operate the robot at low speed to make sure that each part does not interfere with the robot arm and the peripheral devices.  
Confirm that there is no interference also with bellows of the shaft section by clean specification .
- Please be aware that dust may be generated from friction if wires and pipes come into contact with the robot arm when using it according to the clean specifications.
- If you install metal fixtures and a solenoid valve using the screw holes on the No.2 arm portion, add the mass of the metal fixtures and the solenoid valve to mass of a hand then set the HNDDAT parameter. Moreover, Fix the parts, such as a solenoid valve, firmly to prevent the parts getting shaky during operation of a robot.

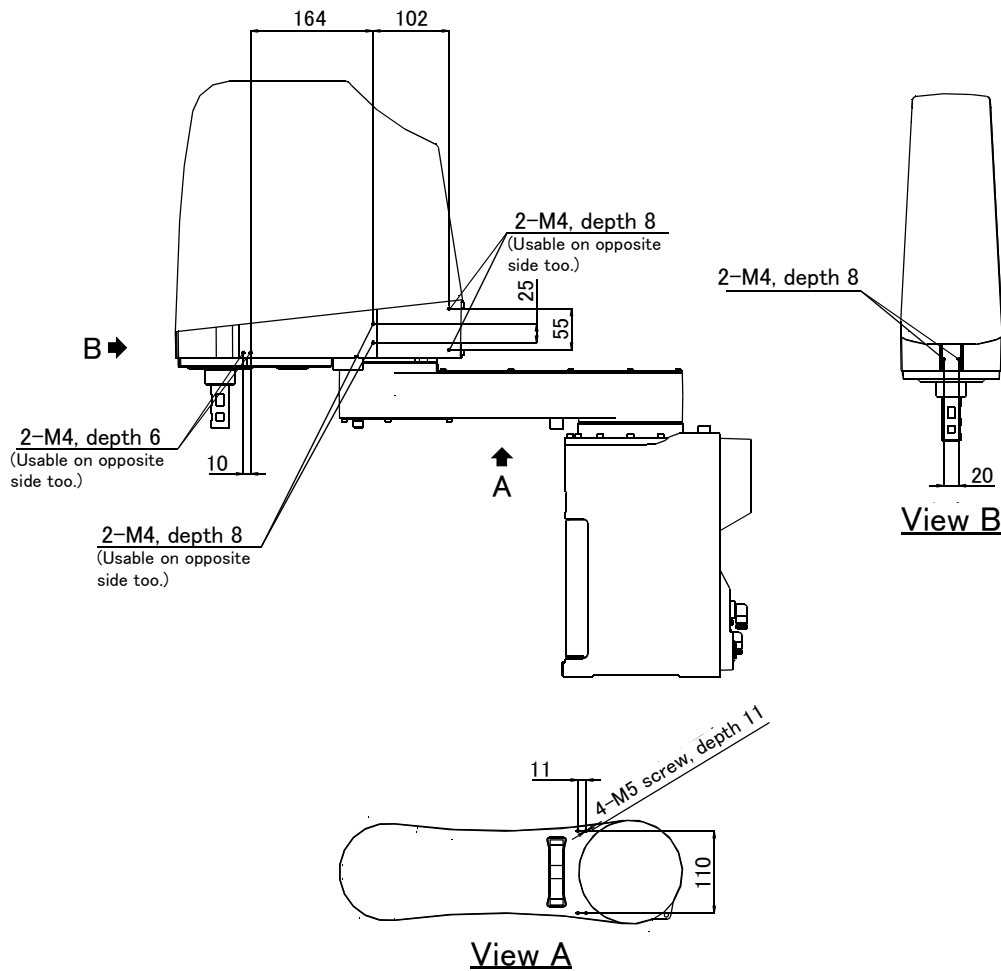

Fig.2-24 : Location of screw holes for fixing wiring/piping

(1) Example of wiring and piping <1>

By feeding wiring and piping through the inside of the shaft, the wiring and piping to the hand becomes compact.

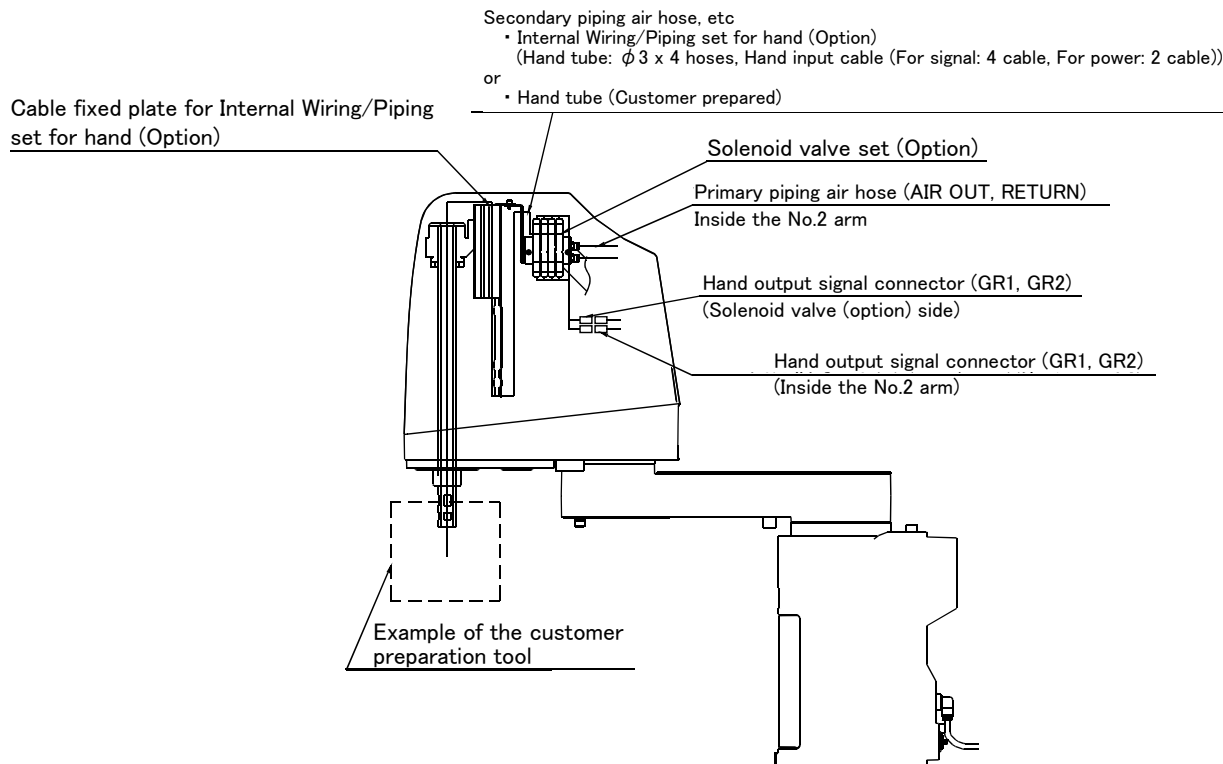

Fig.2-25 : Example of wiring and piping <1>

(2) Wiring and piping example <2>

This is an effective method in cases where the wiring and piping is often changed, or when the hand rotation is minimal (within ±90° ), etc.

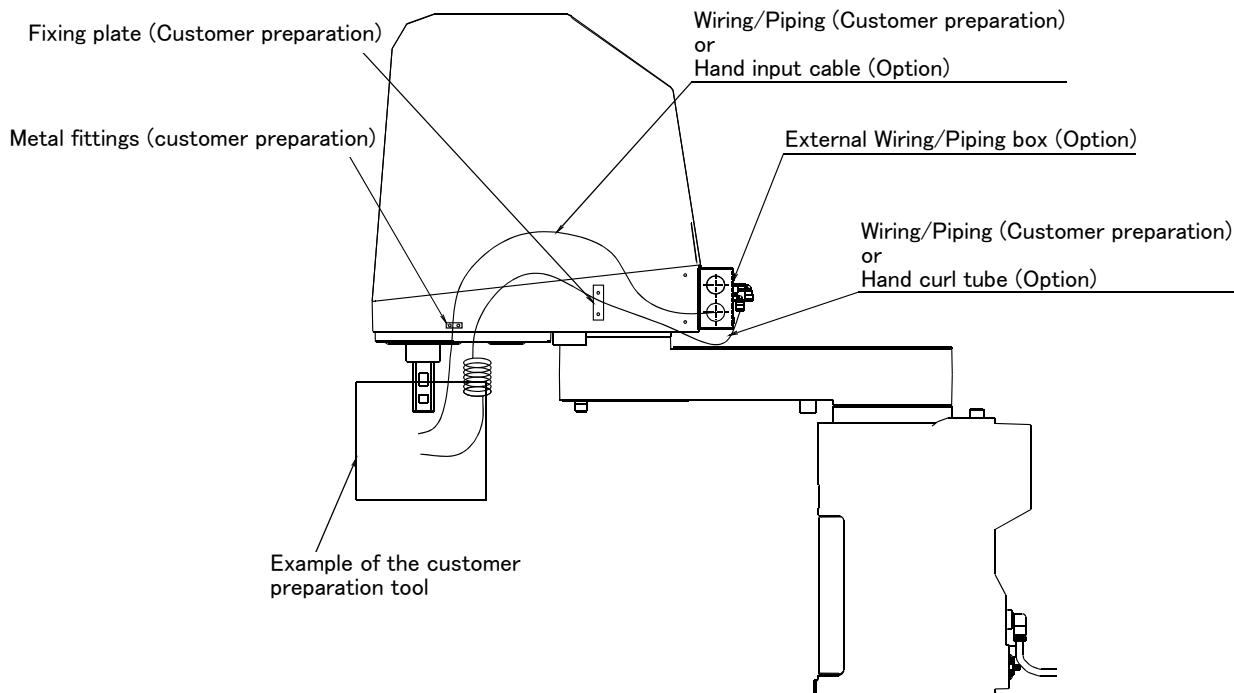

Fig.2-26 : Example of wiring and piping <2>

(3) Precautions for the clean specification

The through hole of the top part of the tip shaft are taped at shipment.

Perform the following actions as necessary in order to ensure that the robot keeps sufficiently protective performance during the operation:

- 1) When the through hole of the shaft is not used
  - Keep the top part of the tip shaft taped while the robot is in use.
- 2) When the through hole of the shaft is used for wiring.
  - Remove the rubber cap on top of the tip shaft and perform the necessary wiring. Once the wiring is completed, seal the bottom part of the tip shaft using liquid seal in order to avoid accumulation of dust
  - Perform the wiring in such a way that the wires around the area below the tip shaft will not get into contact with other parts while the robot is operating.

### 2.5.7 Wiring and piping system diagram for hand

Shows the wiring and piping configuration for a standard-equipped hand.

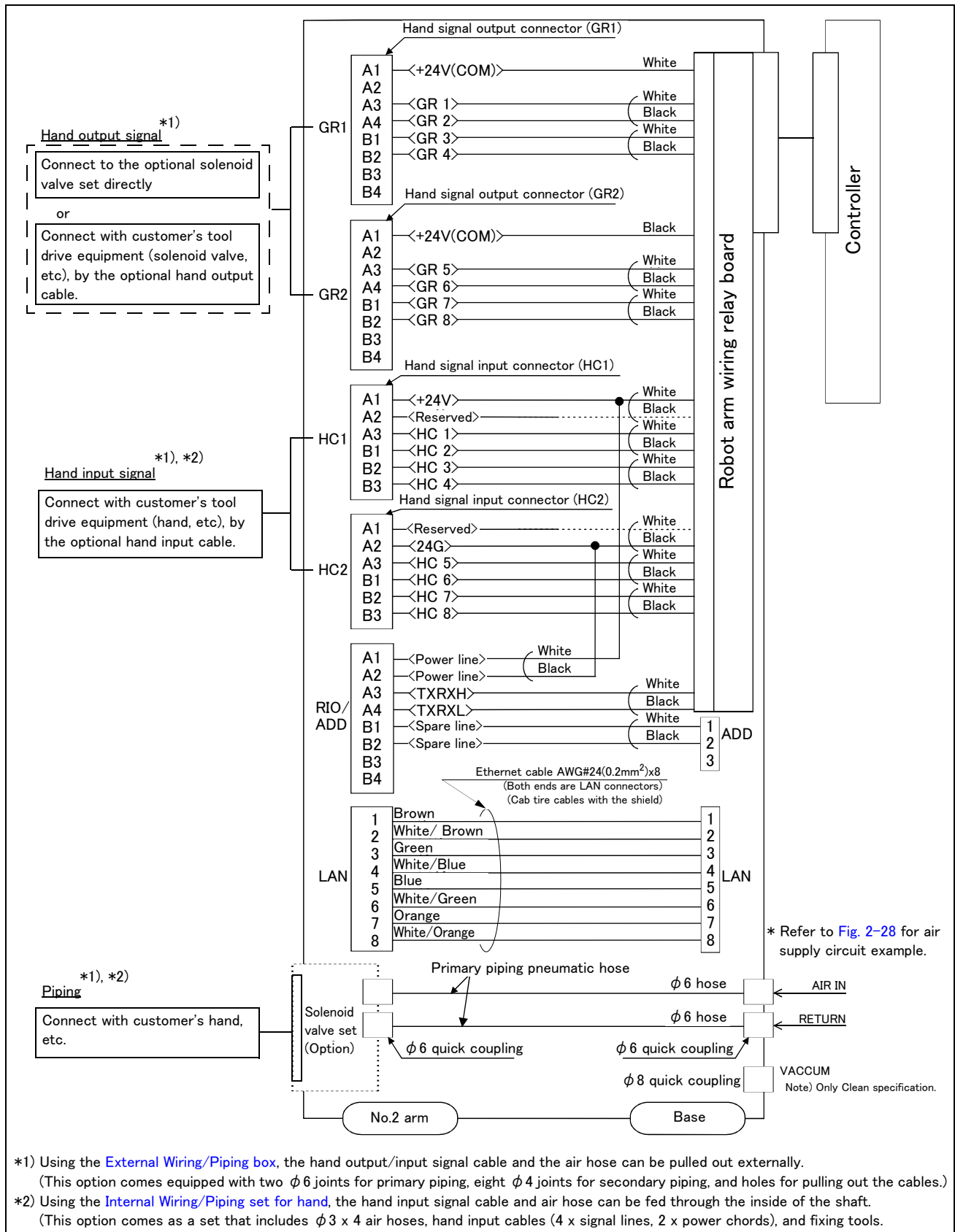

Fig.2-27 : Wiring and piping system diagram for hand and example the solenoid valve installation

2.5.8 Electrical specifications of hand input/output

Table 2-10 : Electrical specifications of input circuit

Item	Specifications	Internal circuit	
Type	DC input	<p>&lt;Sink type&gt;</p>  <p>&lt;Source type&gt;</p>  <p>* HCn = HC1 to HC8</p>	
No. of input points	8		
Insulation method	Photo-coupler insulation		
Rated input voltage	24VDC		
Rated input current	approx. 7mA		
Working voltage range	DC10.2 to 26.4V (ripple rate within 5%)		
ON voltage/ON current	8VDC or more/2mA or more		
OFF voltage/OFF current	4VDC or less/1mA or less		
Input resistance	Approx. 3.3kΩ		
Response time	OFF-ON		10ms or less (DC24V)
	ON-OFF		10ms or less (DC24V)

Table 2-11 : Electrical specifications of output circuit

Item	Specification	Internal circuit	
Type	Transistor output	<p>&lt;Sink type&gt;</p>  <p>&lt;Source type&gt;</p>  <p>* GRn = GR1 to GR8</p>	
No. of output points	8		
Insulation method	Photo coupler insulation		
Rated load voltage	DC24V		
Rated load voltage range	DC21.6 to 26.4VDC		
Max. current load	0.1A/ 1 point (100%)		
Current leak with power OFF	0.1mA or less		
Maximum voltage drop with power ON	DC0.9V(TYP.)		
Response time	OFF-ON		2ms or less (hardware response time)
	ON-OFF		2 ms or less (resistance load) (hardware response time)
Protects	Protects the over-current (0.9A)		

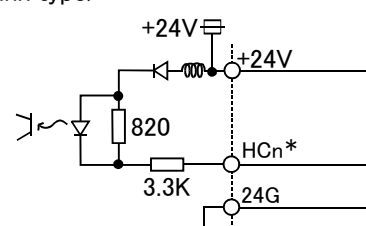
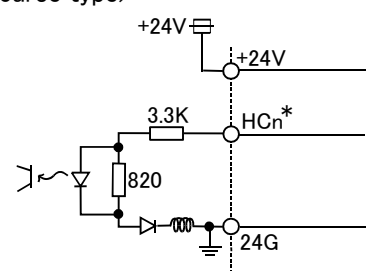
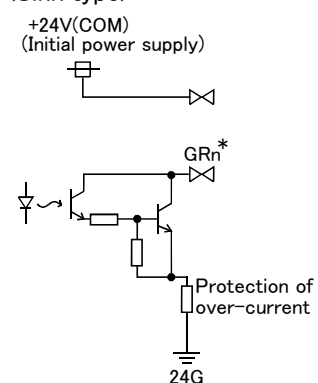
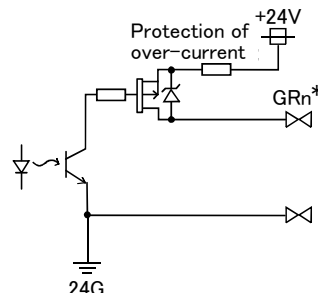

### 2.5.9 Air supply circuit example for the hand

Fig. 2-28 shows an example of pneumatic supply circuitry for the hand.

- (1) Place diodes parallel to the solenoid coil.
- (2) When the factory pneumatic pressure drops, as a result of the hand clamp strength weakening, there can be damage to the work. To prevent it, install a pressure switch to the source of the air as shown in Fig. 2-28 and use the circuit described so that the robot stops when pressure drops. Use a hand with a spring-pressure clamp, or a mechanical lock-type hand, that can be used in cases where the pressure switch becomes damaged.
- (3) The optional hand and solenoid valve are of an oilless type. If they are used, don't use any lubricator.
- (4) Supply clean air to the vacuum generation valve when you use clean type robot.
- (5) If the air supply temperature (primary piping) used for the tool etc. is lower than ambient air temperature, the dew condensation may occur on the coupling or the hose surface.

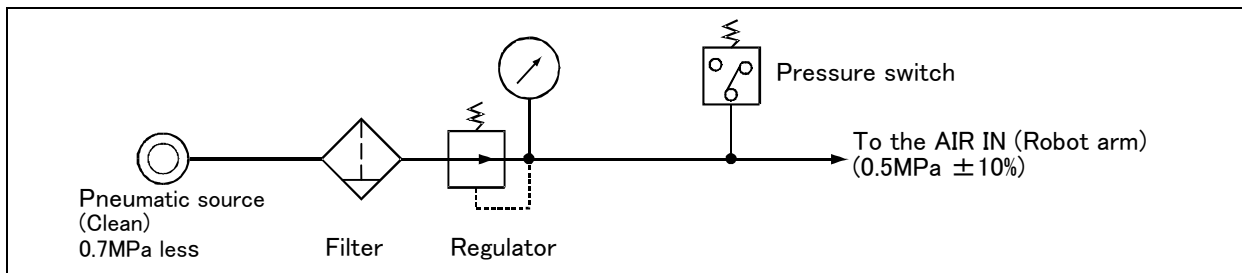

Fig.2-28 : Air supply circuit example for the hand

## 2.6 Shipping special specifications, options, and maintenance parts

### 2.6.1 Shipping special specifications

#### ■ What are shipping special specifications?

Shipping special specifications are changed before shipping from the factory. Consequently, it is necessary to confirm the delivery date by the customer.

To make changes to the specifications after shipment, service work must be performed at the work site or the robot must be returned for service.

#### ■ How to order

- (1) Confirm beforehand when the factory special specifications can be shipped, because they may not be immediately available.
- (2) Specify, before shipping from our company.
- (3) Specified method ····· Specify the part name, model, and robot model type.

(1) Machine cable

- Order type : ● Fixed type ..... CR750 controller: 1S-02UCBL-03 (2m)  
CR751 controller: 1F-02UCBL-02 (2m)

■ Outline

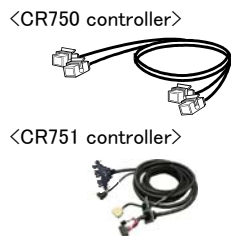

This cable is exchanged for the machine cable (5 m for fixed type) that was supplied as standard to shorten the distance between the controller and the robot arm.

■ Configuration

Table 2-12 : Configuration equipment and types

Part name		Type	Qty.	Mass (Kg) <sup>Note1)</sup>	Remarks <sup>Note2)</sup>
CR750 controller					
Fixed	Set of signal and power cables	1S-02UCBL-03	1 set	2.6	2m
	Motor signal cable		(1 cable)	-	
	Motor power cable		(1 cable)	-	
RCR751 controller					
Fixed	Set of signal and power cables	1F-02UCBL-02	1 set	2.6	2m
	Motor signal cable		(1 cable)	-	
	Motor power cable		(1 cable)	-	

Note1) Mass indicates one set.

Note2) Standard 5 m (for fixed type) is not attached.

[Caution] Orders made after purchasing a robot are treated as purchases of optional equipment. In this case, the machine cable (5 m for fixed type) that was supplied as standard is not reclaimed.

## 2.7 Options

### ■ What are options?

There are a variety of options for the robot designed to make the setting up process easier for customer needs. customer installation is required for the options. Options come in two types: "set options" and "single options".

1. Set options .....A combination of single options and parts that together, from a set for serving some purpose.
2. Single options .....That are configured from the fewest number of required units of a part. Please choose customer's purpose additionally.

## (1) Machine cable extension

- Order type:
- CR750 controller ..... Fixed type: 1S- □□ CBL-03 (extension type)  
Flexed type: 1S- □□ LCBL-03 (extension type)  
Flexed type: 1S- □□ LUCBL-03 (direct type)
  - CR751 controller ..... Fixed type: 1F- □□ UCBL-02 (direct type)  
Flexed type: 1F- □□ LUCBL-02 (direct type)
- Note) □□ refer the length.

## ■ Outline

&lt;CR750 controller&gt;

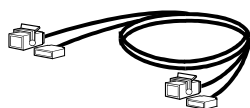

&lt;CR751 controller&gt;



The distance between the robot controller and the robot arm is extensible by this option.

A fixed type and flexible type are available.

The fix and flexible types are both configured of the motor signal cable and motor power cable.

The extended method is discriminated as follows.

Direct type ..... \* Exchanges with the machine cable attached in the standards.

Extension type..... \* Adds to the machine cable attached in the standards.

## ■ Configuration

Table 2-13 : Configuration equipment and types

Part name		Type <sup>Note1)</sup>	Qty.		Mass (kg) <sup>Note2)</sup>	Remarks
			Fixed	Flexed		
<b>CR750 controller</b>						
Fixed	Set of signal and power cables	1S- □□ CBL-03	1 set	-	4.3(5m)	5m, 10m or 15m each Extension type
	Motor signal cable		(1 cable)	-	7.6(10m)	
	Motor power cable		(1 cable)	-	11(15m)	
Flexed	Set of signal and power cables	1S- □□ LCBL-03	-	1 set	6.2(5m)	5m, 10m or 15m each Extension type
	Motor signal cable		-	(1 cable)	11(10m)	
	Motor power cable		-	(1 cable)	15.4(15m)	
Flexed	Set of signal and power cables	1S- □□ LUCBL-03	-	1 set	6.2(5m)	5m, 10m or 15m each Direct type
	Motor signal cable		-	(1 cable)	11(10m)	
	Motor power cable		-	(1 cable)	15.4(15m)	
	Nylon clamp	NK-14N	-	2 pcs.	-	for motor signal cable
	Nylon clamp	NK-18N	-	2 pcs.	-	for motor power cable
	Silicon rubber		-	4 pcs	-	
<b>CR751 controller</b>						
Fixed	Set of signal and power cables	1F- □□ UCBL-02	1 set	-	6.7(10m)	10m, 15m or 20m each Direct type
	Motor signal cable		(1 cable)	-	12(15m)	
	Motor power cable		(1 cable)	-	17(20m)	
Flexed	Set of signal and power cables	1F- □□ LUCBL-02	-	1 set	7(10m)	10m, 15m or 20m each Direct type
	Motor signal cable		-	(1 cable)	13(15m)	
	Motor power cable		-	(1 cable)	17(20m)	
	Nylon clamp	NK-14N	-	2 pcs.	-	for motor signal cable
	Nylon clamp	NK-18N	-	2 pcs.	-	for motor power cable
	Silicon rubber		-	4 pcs	-	

Note1) The numbers in the boxes □□ refer the length.

Note2) Mass indicates one set.

## ■ Specifications

The specifications for the fixed type cables are the same as those for standard cables.  
Shows usage conditions for flexed type cables in [Table 2-14](#).

Table 2-14 : Conditions for the flexed type cables

Item		Specifications	
Cable <sup>Note1)</sup>		1S- □□ LCBL-03, 1S- □□ LUCBL-03	1F- □□ LUCBL-02
Minimum flexed radius		100mm or more	
Cableveyor, etc., occupation rate		50% or less	
Maximum movement speed		2,000mm/s or less	
Guidance of life count		7.5 million times (With silicone grease coating)	
Environmental proof		IP54	IP54 (except for the area approximately 500 mm from the end of the connector on the controller side)
Cable configuration	Motor signal cable	$\phi 6 \times 5$ , $\phi 8.5 \times 1$ , and $\phi 1.7 \times 1$	$\phi 6 \times 7$ and $\phi 1.7 \times 1$
	Motor power cable	$\phi 6.5 \times 10$	$\phi 6.5 \times 8$ and $\phi 8.9 \times 2$

Note1) The square in the cable name indicates the cable length.

[Caution] The guidance of life count may greatly differ according to the usage state items related to [Table 2-14](#) and to the amount of silicon grease applied in the cableveyor.

Recommendation grease: G-501 (Supplier: Shin-Etsu Chemical Co., Ltd.)

[Caution] This option can be installed on clean-type, but its cleanliness is not under warranty.

[Caution] When a cableveyor is used, partitions are required to avoid overlapping or riding up of the cables. Also, adjust the cable length to eliminate tension or excessive looseness, and fix it securely.

## ■ Cable configuration

The configuration of the flexible cable is shown in [Table 2-15](#). Refer to this table when selecting the cableveyor. The configuration is the same between the length difference in the cable, and CR750 controller / CR751 controller.

Table 2-15 : Cable configuration (Flexed type)

Item		Motor signal cable			Motor power cable	
CR750 controller	No. of cores	AWG#24 (0.2mm <sup>2</sup> )-4P	AWG#24 (0.2mm <sup>2</sup> )-7P	AWG#18 (0.75mm <sup>2</sup> )	AWG#18 (0.75mm <sup>2</sup> )-3C	
	Finish dimensions	Approx. $\phi 6$ mm	Approx. $\phi 8.5$ mm	Approx. $\phi 1.7$ mm	Approx. $\phi 6.5$ mm	
	No. of cables used	7 cables	1 cable	1 cable	10 cables	
	No. in total	7 cables			10 cables	
CR751 controller	No. of cores	AWG#24 (0.2mm <sup>2</sup> )-4P	AWG#18 (0.75mm <sup>2</sup> )		AWG#16 (1.25mm <sup>2</sup> )-4C	AWG#18 (0.75mm <sup>2</sup> )-3C
	Finish dimensions	Approx. $\phi 6$ mm	Approx. $\phi 1.7$ mm		Approx. $\phi 8.9$ mm	Approx. $\phi 6.5$ mm
	No. of cables used	7 cables	1 cable		2 cable	8 cable
	No. in total	8 cables			10 cables	

■ Fixing the flexible cable

<CR750 controller>

- (1) Connect the connector to the robot arm.
- (2) Wind the silicon rubber around the cable at a position 300 to 400 mm from the side of robot arm and extension section as shown in Fig. 2-29, and fix with the nylon clamp to protect the cable from external stress.

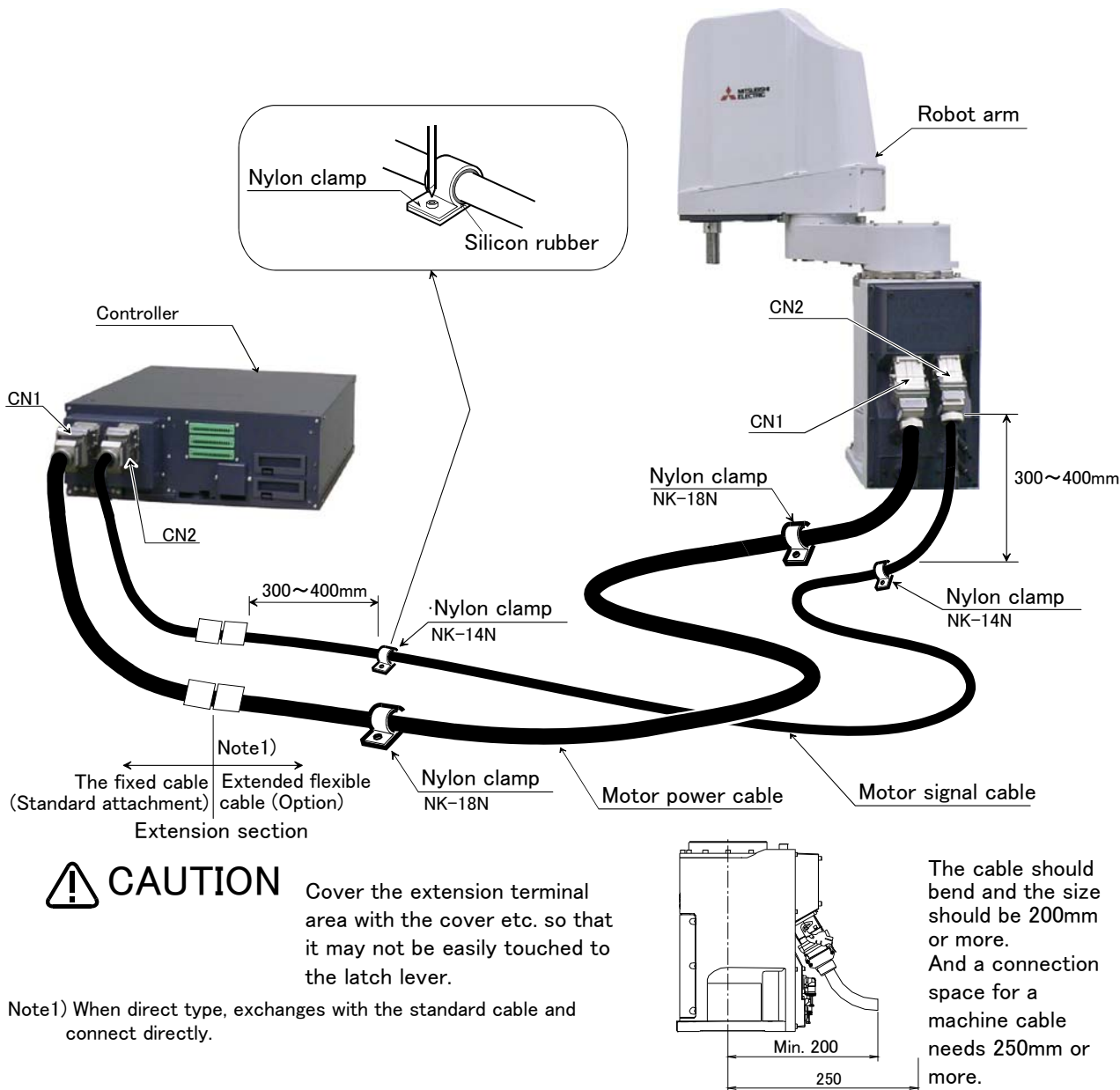

Fig.2-29 : Fixing the flexible cable (CR750)

<CR751 controller>

- (1) Connect the connector to the robot arm.
- (2) For protection of wires from external stress, refer to Fig. 2-30. Wrap the cable with the supplied silicon rubber and fix the cable with nylon clamps in the area between the heat shrink tubes on the robot and the controller sides (flexible cable area).

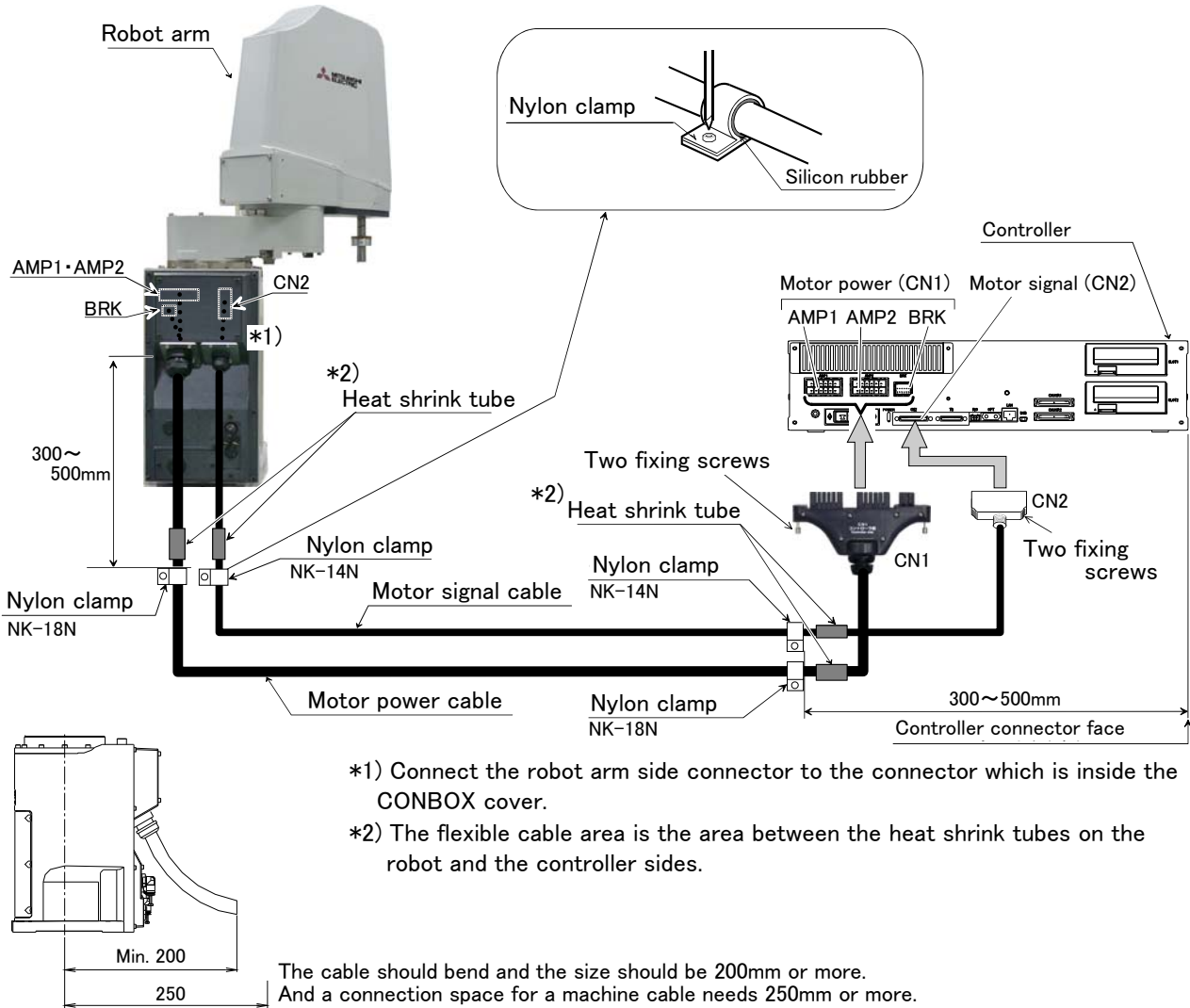

Fig.2-30 : Fixing the flexible cable (CR751)



## (2) Changes J1 axis operating range

■ Order type: 1F-DH-01

■ Outline



The operating range of J1 axis is limited by the robot arm's mechanical stopper and the controller parameters.

If the axis could interfere with the peripheral devices, etc., and the operating range need to be limited, use this.

■ Configuration

Table 2-16 : Configuration devices

Part name	Type	Qty.	Mass(kg)	Remarks
Stopper for changing the operating range	1F-DH-01	1 set	0.05	hexagon socket head bolt (M10 x 20): 2 bolts

■ Specifications

Table 2-17 : Specifications

Axis		Standard	Changeable angle
J1	+/- side	+/- 170 deg	+/- 130 deg, +/- 150 deg

- (1) The changeable angle shown in [Table 2-17](#) indicates the operation range by the software.  
The limit by the mechanical stopper is positioned 3 degrees outward from that angle, so take care when designing the layout.
- (2) The operating range is changed with robot arm settings (insertion of the pin) and parameter settings. Refer to the separate "Instruction Manual/ROBOT ARM SETUP & MAINTENANCE" and "Instruction Manual/Detailed Explanation of Functions and Operations" for details.
- (3) If the arm collides with mechanical stopper for operating range change at the automatic operation, replacement of the mechanical stopper is necessary.

(3) Solenoid valve set

- Order type: One set: 1F-VD01-01(Sink type)/1F-VD01E-01(Source type)  
 Two sets: 1F-VD02-01(Sink type)/1F-VD02E-01(Source type)  
 Three sets: 1F-VD03-01(Sink type)/1F-VD03E-01(Source type)  
 Four sets: 1F-VD04-01(Sink type)/1F-VD04E-01(Source type)

■ Outline



The solenoid valve set is an option that is used for controlling toolings when various toolings, such as the hand, are installed at the end of the arm. Also, for easy installation of this electromaagnetic set onto the robot, it comes equipped with a manifold, couplings, connectors, among other things.

■ Configuration

Table 2-18 : Configuration equipment

Part name	Type	Q'ty	Mass (kg) Note1)	Remark
Solenoid valve set (1 sets)	1F-VD01-01/ 1F-VD01E-01	Either one pc.	1.0	Hand output cable is already connected. Refer to Page 56, "(5) Hand output cable". M4 x 30 Two screws (Installation screws) 1F-VD0*-01: Sink type 1F-VD0*E-01: Source type.
Solenoid valve set (2 sets)	1F-VD02-01/ 1F-VD02E-01	Either one pc.	1.0	
Solenoid valve set (3 sets)	1F-VD03-01/ 1F-VD03E-01	Either one pc.	1.0	
Solenoid valve set (4 sets)	1F-VD04-01/ 1F-VD04E-01	Either one pc.	1.0	

Note1) Mass indicates one set.

■ Specifications

Table 2-19 : Valve specifications

Item	Specifications
Number of positions	2
Port	5 Note1)
Valve function	Double solenoid
Operating fluid	Clean air Note2)
Operating method	Internal pilot method
Effective sectional area (CV value)	0.64mm <sup>2</sup> (0.03)
Oiling	Unnecessary
Operating pressure range	0.1 to 0.7MPa
Response time	22msec or less (at 0.5 MPa)
Max. operating frequency	5Hz
Ambient temperature	-10 to 50 °C (However, there must be no condensation.)

Note1) Couplings of unused solenoid valves must be blocked with plugs. If they are not blocked, supplied air will blow out from the couplings, lowering the air pressure of the solenoid valves being used and making them nonfunctional.

Recommended plugs: KQ2P-04 plug made by SMC

Note2)



**CAUTION**

The air to be provided must be clean, i.e., filtered with a mist separator or air filter. Failing to do so may lead to malfunctions.

Table 2-20 : Solenoid specifications

Item	Specifications
Method	Built-in fly-wheel diodes with surge protection
Coil rated voltage	DC24V ±10%
Power consumption	0.55W
Voltage protection circuit with power surge protection	Diode

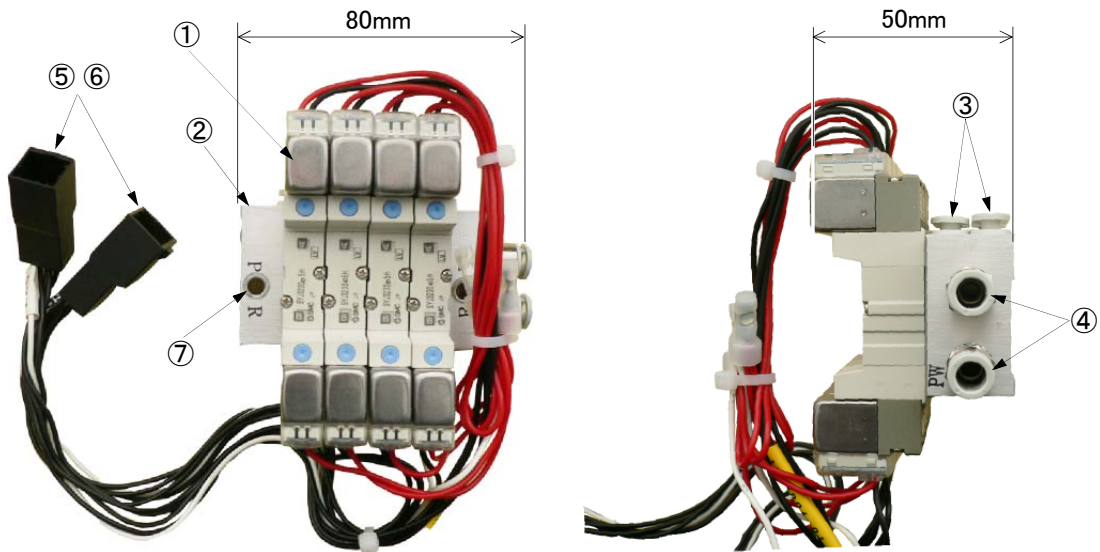

<Sink type>

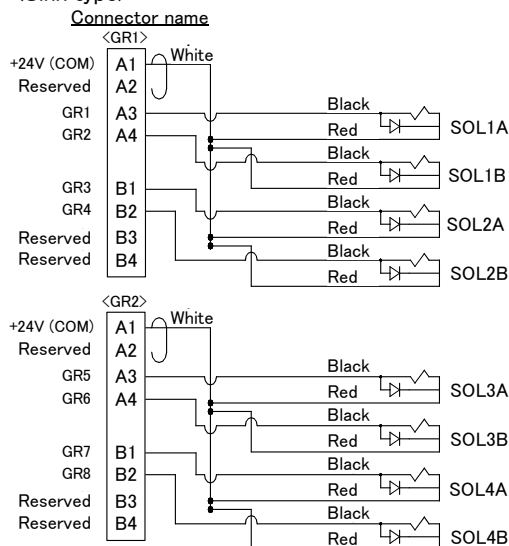

<Source type>

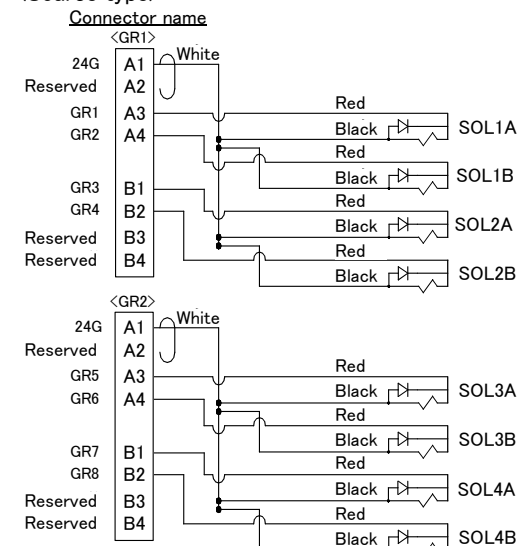

	Part name	1 set	2 sets	3 sets	4 sets	Specification
①	Solenoid valve	1	2	3	4	
②	Manifold block	1	1	1	1	
③	Quick coupling (A/B port)	8	8	8	8	φ 4
④	Quick coupling (P/R port)	2	2	2	2	φ 6
⑤	Connector	1	1	2	2	1-1318115-4
⑥	Contact	3	5	8	10	1318112-1
⑦	Installation screw (Combination slotted-cross recessed pan head machine screw)	2	2	2	2	M4x30

Note) The hand output cable (1F-GR60S-01: Option) is unnecessary.

Fig.2-31 : Outline dimensional drawing

(4) Hand input cable

■ Order type: 1F-HC35C-01

■ Outline

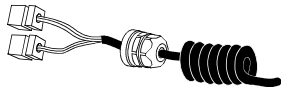

The hand input cable is used for customer-designed pneumatic hands. It is necessary to use this to receive the hand's open/close confirmation signals and grasping confirmation signals, at the controller. One end of the cable connects to the connector for hand input signals, which is in the wrist section of the hand. The other end of the cable connected to the sensor inside the hand customer designed. To extend the wiring to the outside of the robot arm, optional external wiring and piping box (1F-UT-BOX) is required.

■ Configuration

Table 2-21 : Configuration equipment

Part name	Type	Qty.	Mass (kg) <sup>Note1)</sup>	Remarks
Hand input cable	1F-HC35C-01	1 cable	0.2	

Note1) Mass indicates one set.

■ Specifications

Table 2-22 : Specifications

Item	Specifications	Remarks
Size x cable core	AWG#24 (0.2mm <sup>2</sup> ) × 12	One-sided connector, one-sided cable bridging
Total length	1,650mm (Including the curl section, which is 350mm long)	

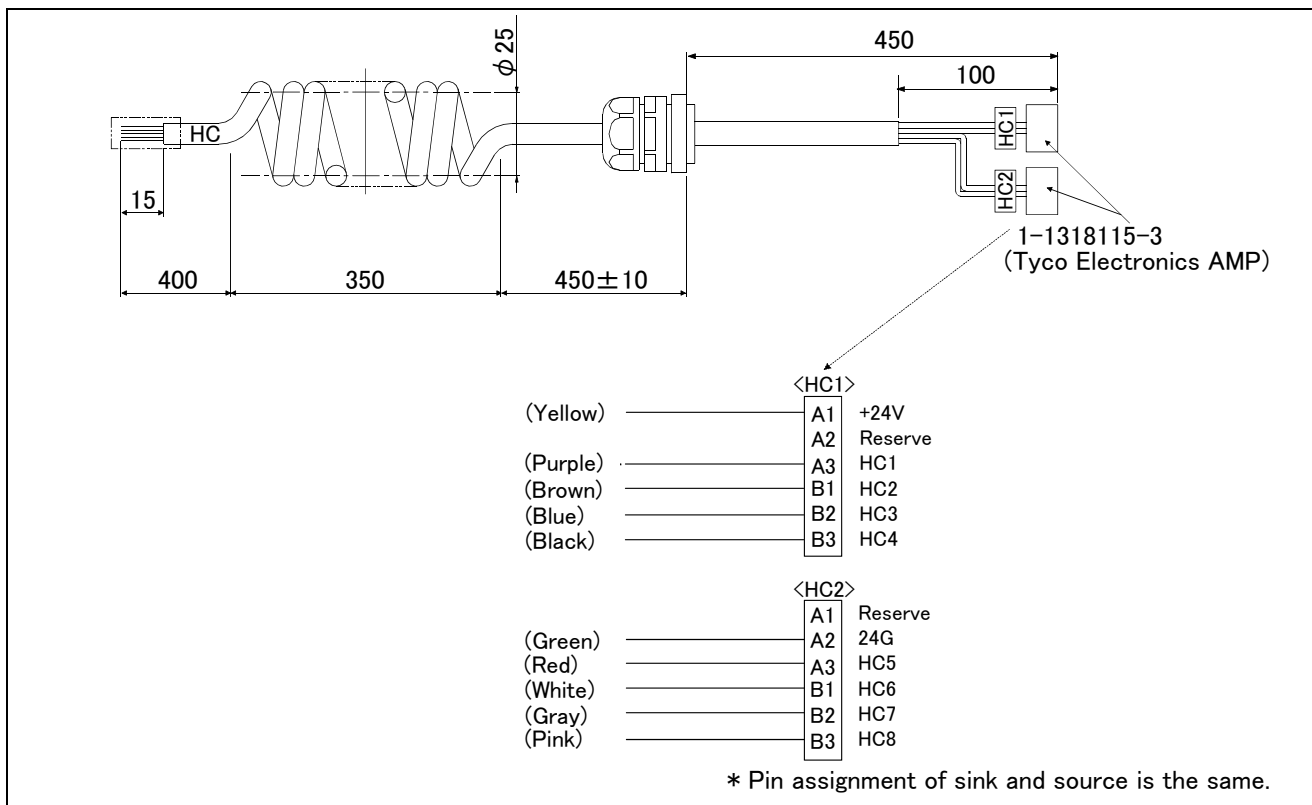

Fig.2-32 : Outside dimensional drawing and pin assignment

[Caution] This option can be installed on clean-type, but its cleanliness is not under warranty.

(5) Hand output cable

■ Order type: 1F-GR60S-01

■ Outline

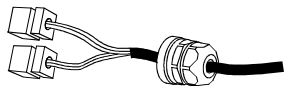

The hand output cable (solenoid valve connection cable) is an option that is used when a solenoid valve other than one of the solenoid valve set options, is used. One end of the cable has a connector that connects to the input terminal inside the robot. The other end of the cable is connected. To extend the wiring to the outside of the robot arm, optional external wiring and piping box (1F-UT-BOX) is required.

■ Configuration

Table 2-23 : Configuration equipment

Part name	Type	Qty.	Mass (kg) <sup>Note1)</sup>	Remarks
Hand output cable	1F-GR60S-01	1 cable	0.3	

Note1) Mass indicates one set.

■ Specifications

Table 2-24 : Specifications

Item	Specifications	Remarks
Size x Cable core	AWG#24(0.2mm <sup>2</sup> ) x 12 cores	One side connector and one side cable connection
Total length	1,050mm	

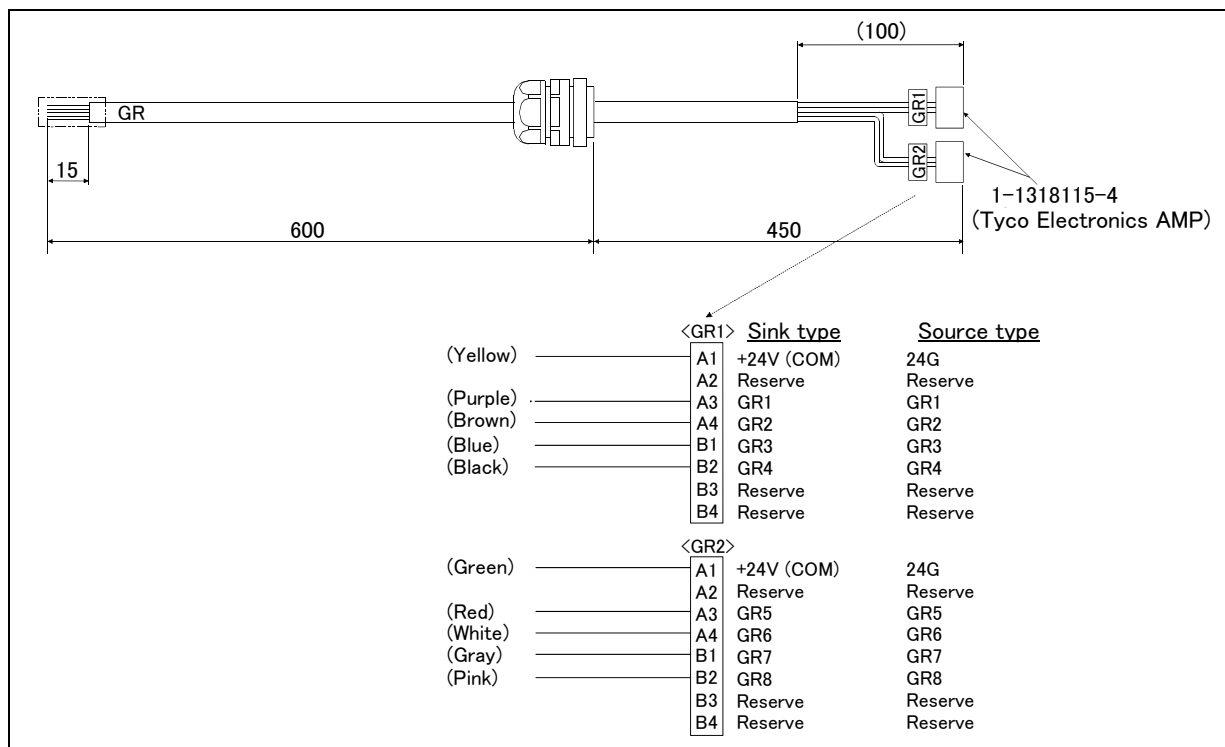

Fig.2-33 : Outline dimensional drawing and pin assignment

[Caution] This option can be installed on clean-type, but its cleanliness is not under warranty.

(6) Hand curl tube

■ Order type: Four sets.....1E-ST0408C-300

■ Outline

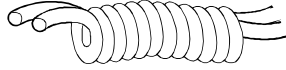

The hand curl tube is a curl tube for the pneumatic hand.

■ Configuration

Table 2-25 : Configuration equipment

Part name	Type	Qty.	Mass (kg) <sup>Note1)</sup>	Remarks
Hand curl tube (Four set: 8 pcs.)	1E-ST0408C-300	1 pc.	0.1	Φ 4 tube, 8pcs

Note1) Mass indicates one set.

■ Specifications

Table 2-26 : Specifications

Item	Specifications
Material	Urethane
Size	Outside diameter: $\phi 4$ x Inside diameter: $\phi 2.5$

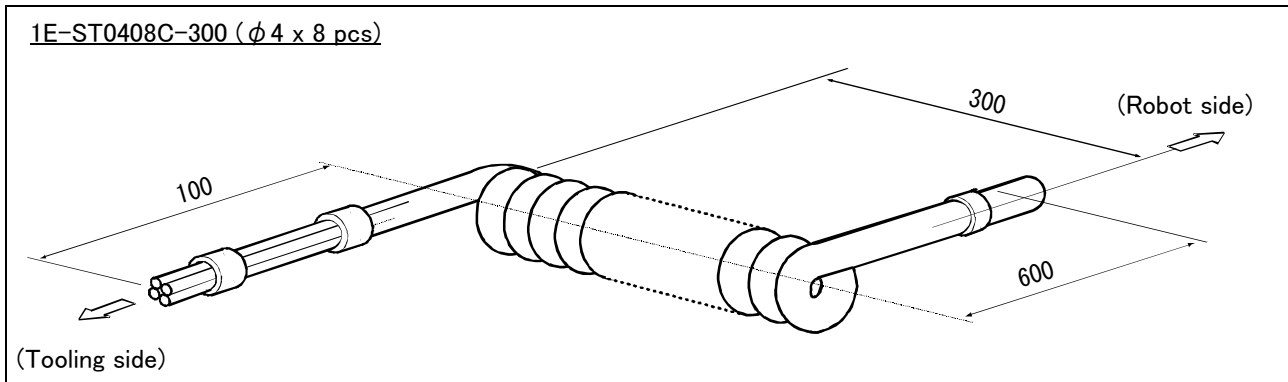

Fig.2-34 : Outline dimensional drawing

[Caution] This option can be installed on clean-type, but its cleanliness is not under warranty.

(7) Internal Wiring/Piping set for hand

■ Order type: 1F-HS304S-01

■ Outline

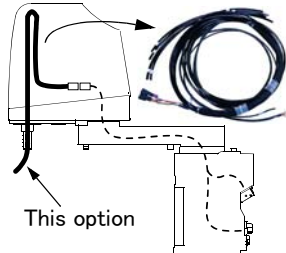

This set, consisting of air hoses and cables, is for feeding air hoses and hand input signal cables from the No. 2 arm through to the shaft tip.  
 A plate is already attached to be fixed onto the No. 2 arm, and therefore it is easy to ensure the necessary space for wiring and piping.  
 This can be used together with the separately sold electromagnetic valve set option.

■ Configuration

Table 2-27 : Configuration equipment

Item	Type	Qty.	Mass (Kg) <sup>Note1)</sup>	Remarks
Internal Wiring/Piping set for hand	1F-HS304S-01	1	0.4	The air hose and the cable for hand input signals are contained. The grease (for application to shaft top) and the union band (for fixation of the hose and the cable) are attached.

Note1) Mass indicates one set.

■ Specification

Table 2-28 : Specification

Item	Specification	Remarks
Air hose	$\phi 3 \times 4$ pcs	Both ends are free. Eight reducers ( $\phi 3$ to $\phi 4$ ) are attached.
Hand input signal cable	AWG #24(0.2mm <sup>2</sup> ) $\times$ 6pcs	The robot arm side is connector (HC1, HC2), and one side is free.
Useable length from the shaft end	400mm	The length from the shaft end which can be used of customer.

[Caution] This option can be installed on clean-type, but its cleanliness is not under warranty.

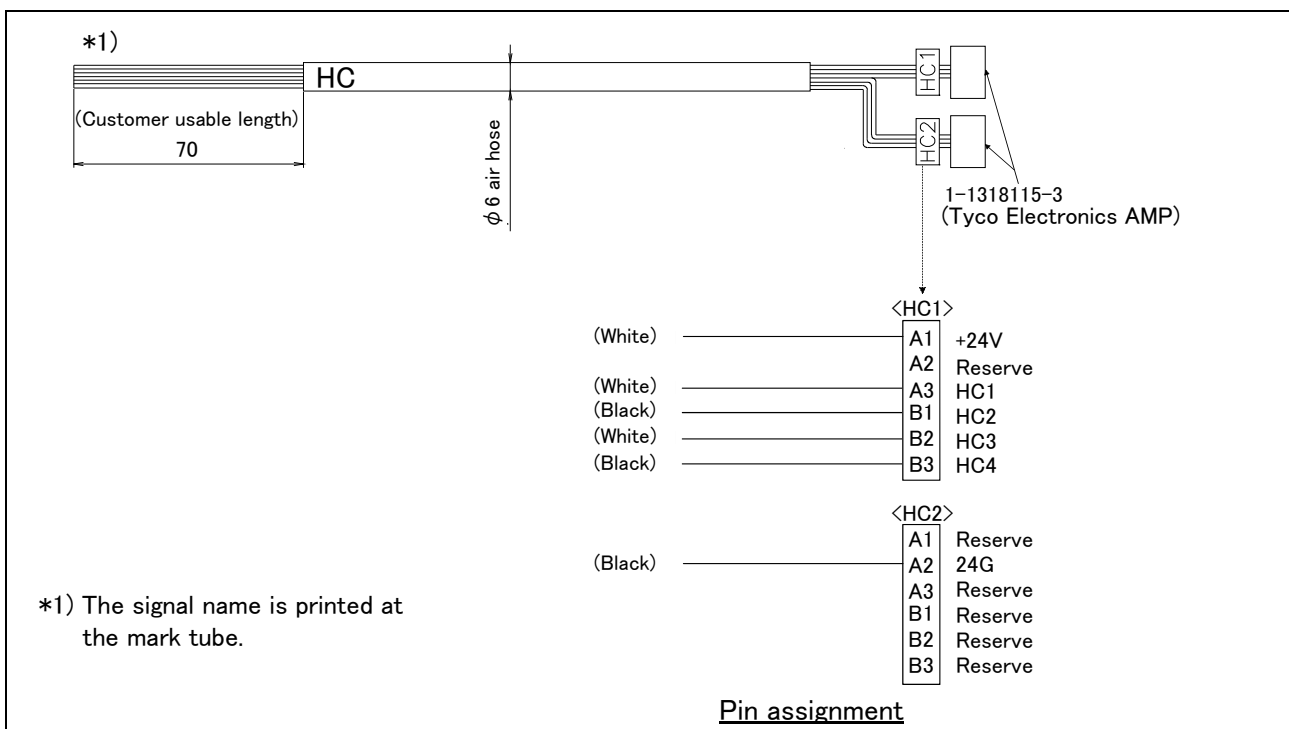
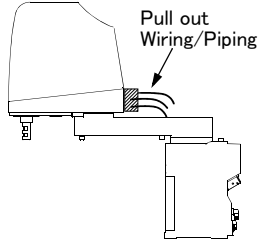

Fig.2-35 : Outline dimension drawing and pin assignment (Hand input cable)

(8) External Wiring/Piping box

■ Order type: 1F-UT-BOX

■ Outline



This is a very useful option when removing the air hoses and signal lines from the rear of the No. 2 arm, and pulling hand wiring and piping out to the robot's exterior. The joint for connects to the external hose is prepared, and the holes which fixes the signal cable to pull out with cable clamp are prepared. Optional hand output cables and hand input cables can be fixed here.

This option can also be used on the clean specifications.

■ Configuration

Table 2-29 : Configuration equipment

Part name	Type	Qty.	Mass (Kg) <sup>Note1)</sup>	Remarks
External Wiring/Piping box	1F-UT-BOX	1	0.5	Attachments: • Eight Air hoses ( $\phi 4$ , connect to solenoid valve) • Installation screw M4 x 12: 4 screws (Conical spring washer, Plain washer) • Simple spanner for resin nuts

Note1) Mass indicates one set.

■ Specification

Table 2-30 : Specification

Item	Specification	Remarks
Outline	106(W) x 73.6(D) x 72(H)	The coupling is included.
The hole for wiring drawers	$\phi 21 \times 4$ places	Fix the cable by cable clamp etc.
Coupling	For $\phi 4$ air hose x 8pcs	Installed previously
	For $\phi 6$ air hose x 2pcs	

An outside dimension and a component are shown in [Fig. 2-36](#).



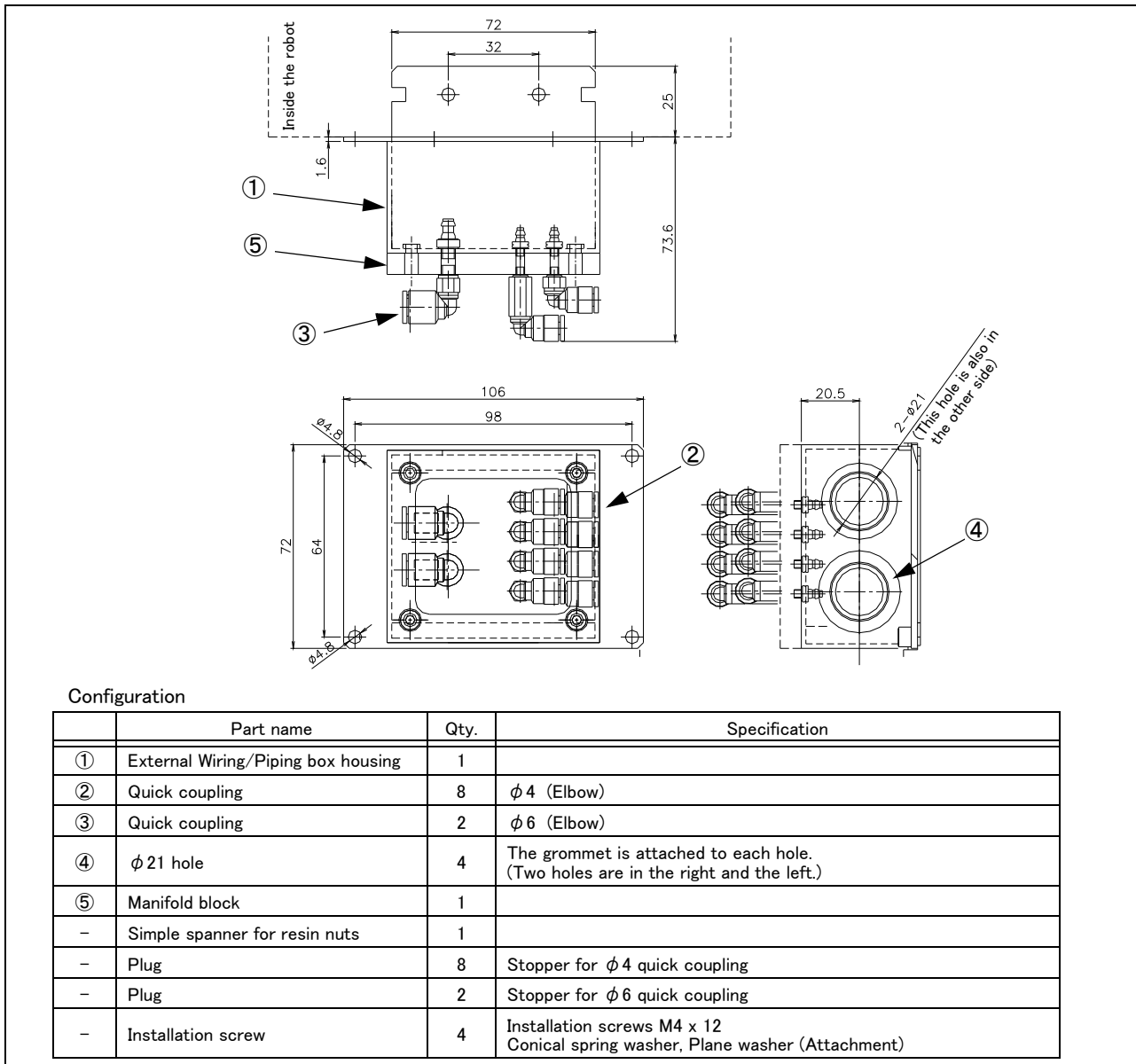

Fig.2-36 : Outline dimension and configurations

## 2.8 About Overhaul

Robots which have been in operation for an extended period of time can suffer from wear and other forms of deterioration. In regard to such robots, we define overhaul as an operation to replace parts running out of specified service life or other parts which have been damaged, so that the robots may be put back in shape for continued use. Overhaul interval for robots presumably varies with their operating conditions and thus with the degree of the equipment's wear and loss of performance. As a rule of thumb, however, it is recommended that overhaul be carried out before the total amount of servo-on time reaches the predetermined levels (24,000 hours for the robot body and 36,000 hours for the controller). (See Fig. 2-37.) For specific information about parts to be replaced and timing of overhaul, contact your local service representative.

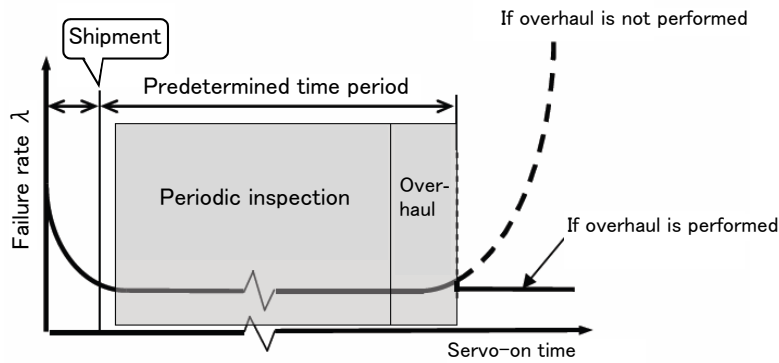

Fig.2-37 : Periodic inspection/overhaul periods

## 2.9 Maintenance parts

The consumable parts used in the robot arm are shown in [Table 2-31](#). Purchase these parts from the designated maker or dealer when required. Some Mitsubishi-designated parts differ from the maker's standard parts. Thus, confirm the part name, robot arm and controller serial No. and purchase the parts from the dealer.

Table 2-31 : Consumable part list

No.	Part name	Type <sup>Note1)</sup>	Usage place	Qty.	Supplier
1	Grease		Reduction gears of each axis	As needed	Mitsubishi Electric
2			Ball screw spline	As needed	
3	Lithium battery	ER6	Front section of the base	3	
4	Timing belt		J3 axis	1	Mitsubishi Electric
5			J4 axis motor side	1	
6			J4 axis shaft side	1	

Note1) Confirm the robot arm serial No., and contact the dealer or service branch of Mitsubishi Electric Co., for the type.

### 3 Controller

#### 3.1 Standard specifications

##### 3.1.1 Basic specifications

Table 3-1 : Specifications of controller

Item	Unit	Specification	Remarks	
Type		CR751-03HD-0 CR751-03HD1-0-S15 CR750-03HD1-1-S15	“-S15” means CE marking specification.	
Number of control axis		Simultaneously 4		
Memory capacity	Programmed positions	point	39,000	
	No. of steps	step	78,000	
	Number of program		512	
Robot language		MELFA-BASIC IV, V		
Teaching method		Pose teaching method, MDI method <sup>Note1)</sup>		
External input and output	Input and output	point	0/0	Max. 256/256 by option
	Dedicated input/output		Assigned with general-purpose input/output	The signal number of “STOP” input signals is fixing.
	Hand open/close input/output	point	8/8	Built-in
	Emergency stop input	point	1	Dual line
	Door switch input	point	1	Dual line
	Enabling device input	point	1	Dual line
	Emergency stop output	point	1	Dual line
	Mode output	point	1	Dual line
	Robot error output	point	1	Dual line
	Addition axis synchronization	point	1	Dual line
Mode changeover switch input	point	1	Dual line (CR751 controller only)	
Interface	RS-422	port	1	Only for T/B
	Ethernet	port	1	10BASE-T/100BASE-Tx
	USB	port	1	Ver.2.0 FullSpeed Only device function
	Additional axis interface	Channel	1	SSCNET III (Connects with MR-J3-BS, MR-J4-B series)
	Tracking interface	Channel	2	
	Option slot	slot	2	For option interface
Power source	Input voltage range	V	Single phase, AC180 to 253	
	Power capacity	kVA	0.5	Does not include rush current <sup>Note2)</sup>
	Power supply frequency	Hz	50/60	
Outline dimensions <sup>Note3)</sup>	mm	CR750 controller 430(W) x 425(D) x 174(H)	Excluding protrusions	
		CR751 controller 430(W) x 425(D) x 98(H)		
Mass	kg	CR750: Approx. 16		
		CR751: Approx. 12		
Construction		Self-contained floor type, Opened type. Installation vertically or horizontally	IP20 <sup>Note4)</sup>	
Operating temperature range	°C	0 to 40		
Ambient humidity	%RH	45 to 85	Without dew drops	
Grounding	Ω	100 or less	100Ω or less (class D grounding) <sup>Note5)</sup>	
Paint color		Dark gray	Equivalent to Munsell: 3.5PB3.2/0.8	

Note1) Pose teaching method: The method to register the current position of the robot arm.

MDI method: The method to register by inputting the numerical value Immediate.

Note2) The power capacity is the rating value for normal operation. The power capacity does not include the rush current when the power is turned ON. The power capacity is a guideline and the actual operation is affected by the input power voltage. The power consumption in the specific operation pattern with the RH-3FH is approx. 0.3kW. The short circuit breaker should use the following.

\* Operate by the current leakage under the commercial frequency domain (50–60Hz). If sensitive to the high frequency ingredient, it will become the cause in which below the maximum leak current value carries out the trip.

Note3) Refer to [Page 69, "3.3.1 Outside dimensions"](#) for details.

Note4) This controller is standard specification. (Refer to [Page 64, "3.1.2 Protection specifications and operating supply"](#).)

Note5) The robot must be grounded by the customer.

### 3.1.2 Protection specifications and operating supply

A protection method complying with the IEC Standard IP20 (Opened type) is adopted for the controller. The IEC IP symbols refer only to the degree of protection between the solid and the fluids, and don't indicated that any special protection has been constructed for the prevention against oil and water.

#### 【Information】

- The IEC IP20

It indicates the protective structure that prevents an iron ball  $12^{+0.05}_0$  mm diameter, which is being pressed with the power of  $3.1 \text{ kg} \pm 10\%$ , from going through the opening in the outer sheath of the supplied equipment.

Refer to the section [Page 152, "6.2 Working environment"](#) for details on the working environment.

3.2 Names of each part

3.2.1 Controller

(1) CR750 controller

Controller (Front side)

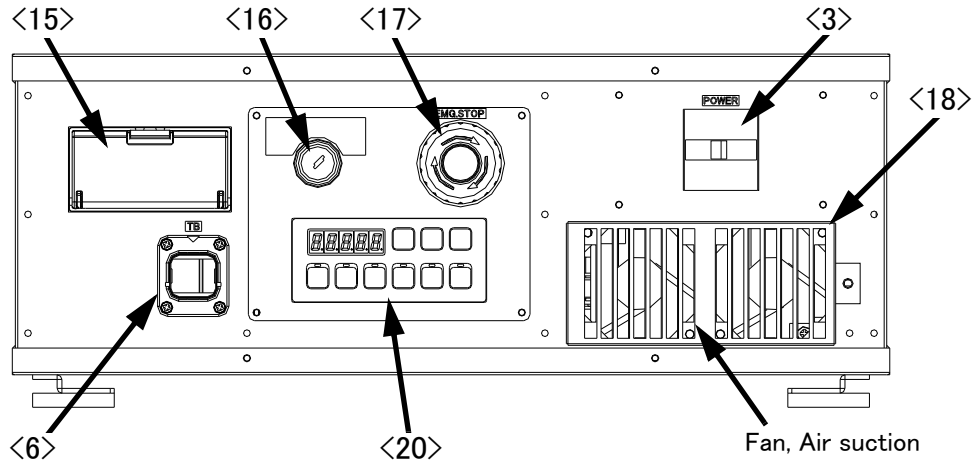

Controller (Rear side)

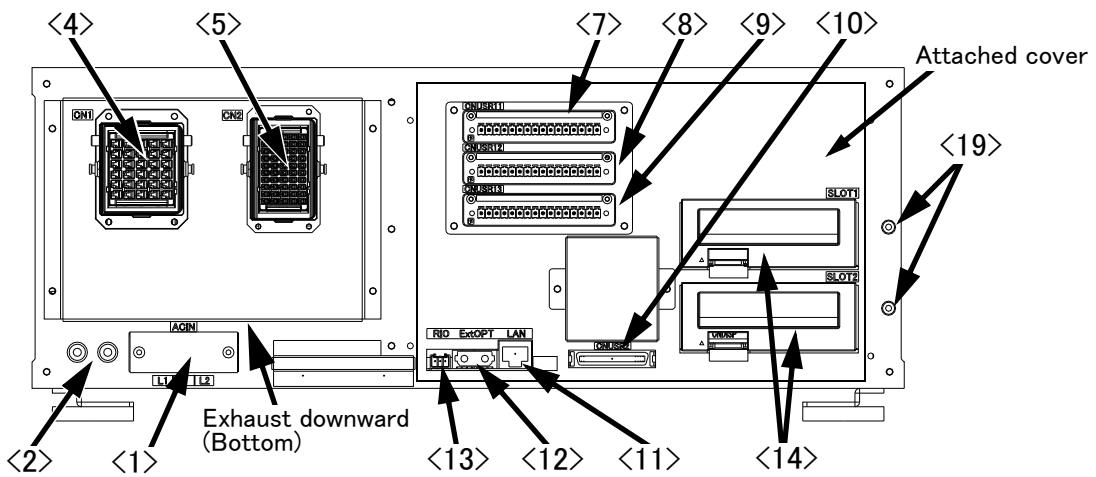

<1>: ACIN terminal

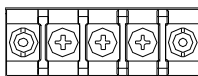

There are two types (Type A and C) of terminal. Refer to next page for details.

<20>: The operation panel

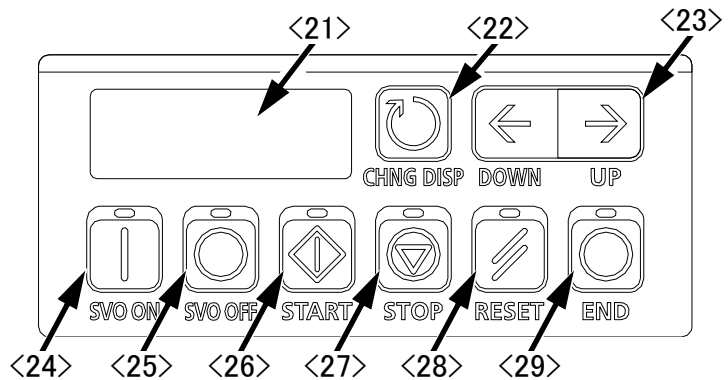
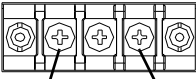
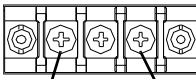

Fig.3-1 : Names of controller parts (CR750)

- <1> ACIN terminal ..... The terminal box for AC power source (single phase, AC200V) input. (Inner side of a cover)  
There are two types of the terminal and the terminal differs depending on the specification (CE or non-CE).

Specification	Non-CE specification	CE specification
Type of ACIN terminal	<p><u>Type A:</u> For single phase</p>  <p>L1 L2</p> <p>Connect the primary power supply to L1 and L2 terminal.</p>	<p><u>Type C:</u> For single phase</p>  <p>L1 N</p> <p>Connect the primary power supply to L1 and N terminal.</p>

Refer to a separate manual "INSTRUCTION MANUAL/Controller setup, basic operation, and maintenance" for how to connect a power cable.

- <2> PE terminal ..... The screw for grounding of the cable. (M4 screw x 2 place)
- <3> Power switch ..... This turns the control power ON/OFF
- <4> Machine cable connector (motor signal) (CN1)  
Connect with the CN1 connector of the robot arm.
- <5> Machine cable connector (motor power) (CN2)  
Connect with the CN2 connector of the robot arm.
- <6> T/B connection connector (TB) ..... This is a dedicated connector for connecting the T/B. When not using T/B, connect the attached dummy connector.
- <7><8><9><10> CNUSR connector ..... The connector for input/ output connection dedicated for robot. (a plug connector attached)  
<7>: CNUSR11, <8>: CNUSR12, <9>: CNUSR13, <10>: CNUSR2  
Refer to a separate manual "INSTRUCTION MANUAL/Controller setup, basic operation, and maintenance" for the connection method and the further description of pin assign.
- <11> LAN connector (LAN) ..... For LAN connection
- <12> ExtOPT connector (ExtOPT) ..... Connect the cable for addition axis control.
- <13> RIO connector (RIO) ..... Connect the extension parallel input/output unit.
- <14> Option slot (SLOT1, SLOT2) ..... Install the interface optional. (Install the cover, when not using.)
- <15> Interface cover ..... USB interface and battery are mounted.
- <16> Mode key switch ..... This key switch changes the robot's operation mode.  
**AUTOMATIC** ..... Operations from the controller or external equipment are valid. Operations for which the operation mode must be at the external device or T/B are not possible. (Exclude the start of automatic operation.)  
**MANUAL** ..... When the T/B is valid, only operations from the T/B are valid. Operations for which the operation mode must be at the external device or controller are not possible.
- <17> Emergency stop switch ..... This switch stops the robot in an emergency state. The servo turns OFF.
- <18> Filter cover ..... There is an air filter inside the cover.
- <19> Grounding terminal ..... The grounding terminal for connecting cables of option card. (M3 screw x 2 places)
- <20> Operation panel ..... The operation panel for servo ON/OFF, START/STOP the program etc.
- <21> Display panel (STATUS.NUMBER) ..... The alarm No., program No., override value (%), etc., are displayed.
- <22> CHNGDISP button ..... This button changes the details displayed on the display panel in the order of "Override" → "Program No." → "Line No."
- <23> UP/DOWN button ..... This scrolls up or down the details displayed on the "STATUS. NUMBER" display panel.
- <24> SVO.ON button ..... This turns ON the servo power. (The servo turns ON.)
- <25> SVO.OFF button ..... This turns OFF the servo power. (The servo turns OFF.)
- <26> START button ..... This executes the program and operates the robot. The program is run continuously.
- <27> STOP button ..... This stops the robot immediately. The servo does not turn OFF.
- <28> RESET button ..... This resets the error. This also resets the program's halted state and resets the program.
- <29> END button ..... This stops the program being executed at the last line or END statement.

(2) CR751 controller

Controller (Front side)

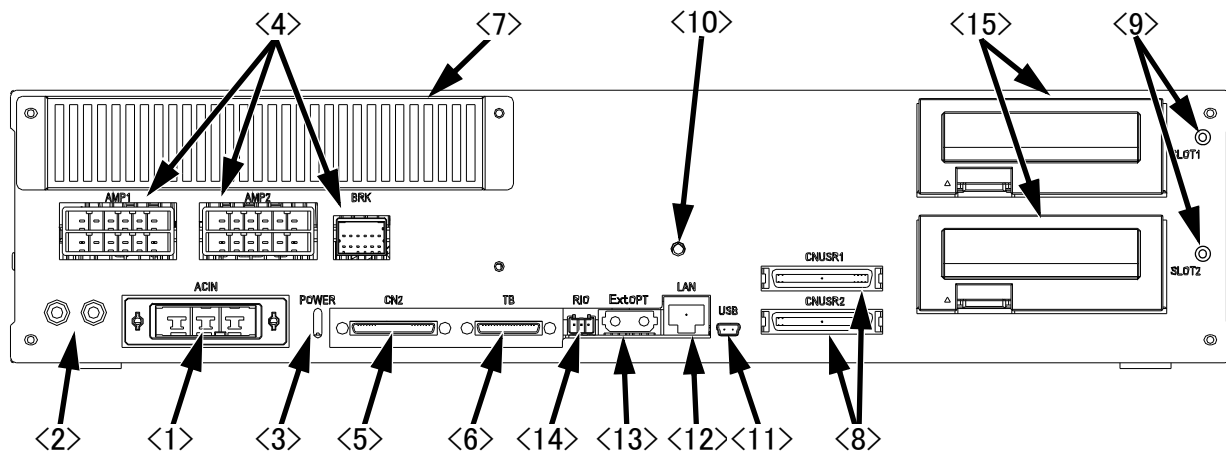

Controller (Rear side)



Fig.3-2 : Names of controller parts (CR751)

- <1> ACIN connector.....The connector for AC power source (single phase, AC200V) input (a socket housing and a terminal are attached).  
Refer to a separate manual “INSTRUCTION MANUAL/Controller setup, basic operation, and maintenance” for how to connect a power cable.
- <2> PE terminal.....The screw for grounding of the cable. (M4 screw x 2 place)
- <3> POWER lamp.....Lamp of control power source
- <4> Machine cable connector (motor power)  
AMP1, AMP2: Motor power, BRK: Motor brake
- <5> Machine cable connector (motor signal)  
CN2: Motor signal
- <6>T/B connection connector (TB).....This is a dedicated connector for connecting the R33TB. When not using T/B, connect the attached dummy plug.
- <7>Filter cover.....There is an air filter and butterfly inside this cover.
- <8>CNUSR connector.....The connector for input/ output connection dedicated for robot.  
(CNUSR1、CNUSR2)  
(a plug connector attached)  
Refer to a separate manual “INSTRUCTION MANUAL/Controller setup, basic operation, and maintenance” for the connection method and the further description of pin assign.
- <9>Grounding terminal.....The grounding terminal for connecting cables of option card. (M3 screw x 2 places)
- <10>Power supply charge lamp (CRARGE)  
The lamp is to ensure safe timing (prevent electric shocks) when removing the cover (users are not normally required to remove the cover).  
This lamp is illuminated (red) when electrical energy accumulates on the controller’s power supply circuit board due to the robot’s servo being ON.



---

After turning the control power OFF and allowing a few minutes to pass, the lamp will go out.

- <11>USB connecting connector (USB)..For USB connection
- <12>LAN connector (LAN) .....For LAN connection
- <13>ExtOPT connector (ExtOPT).....Connect the cable for addition axis control.
- <14>RIO connector (RIO).....Connect the extension parallel input/output unit.
- <15>Option slot .....Install the interface optional. (Install the cover, when not using.)  
(SLOT1、SLOT2)

### Caution

Use the network equipments (personal computer, USB hub, LAN hub, etc) confirmed by manufacturer. The thing unsuitable for the FA environment (related with conformity, temperature or noise) exists in the equipments connected to USB. When using network equipment, measures against the noise, such as measures against EMI and the addition of the ferrite core, may be necessary. Please fully confirm the operation by customer. Guarantee and maintenance of the equipment on the market (usual office automation equipment) cannot be performed.

### 3.3 Outside dimensions/Installation dimensions

#### 3.3.1 Outside dimensions

##### (1) CR750 controller

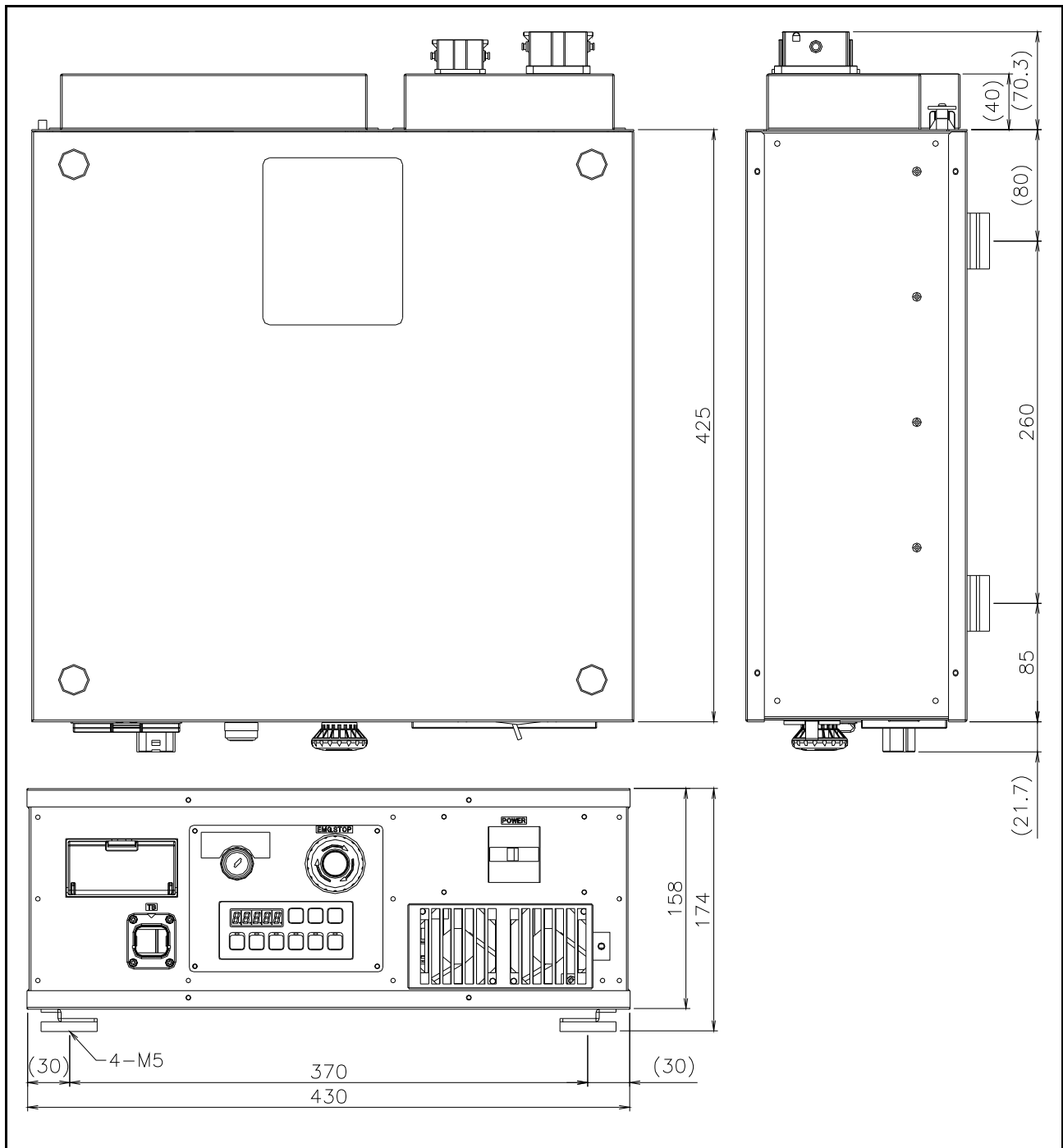

Fig.3-3 : Outside dimensions of controller (CR750)

(2) CR751 controller

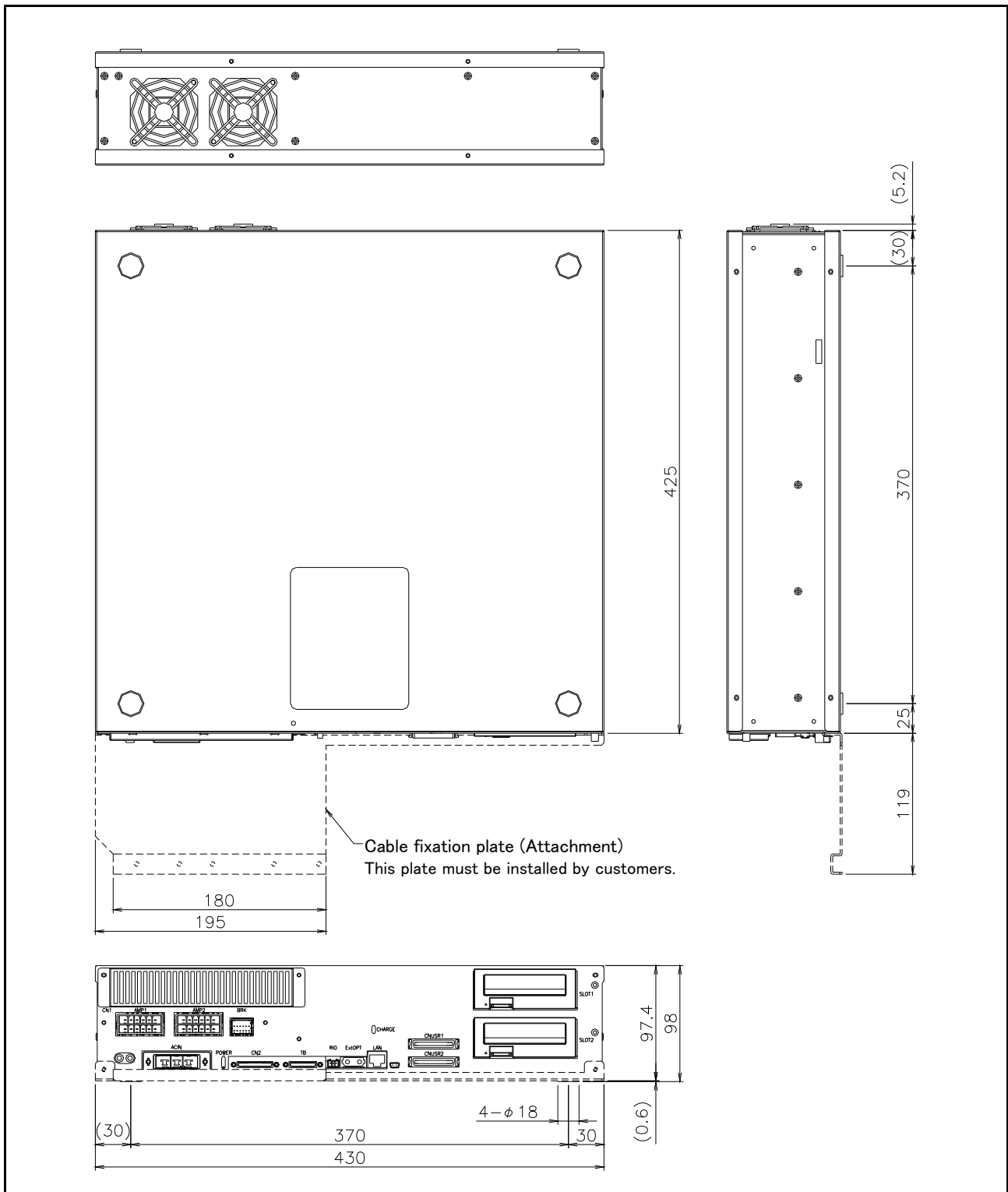
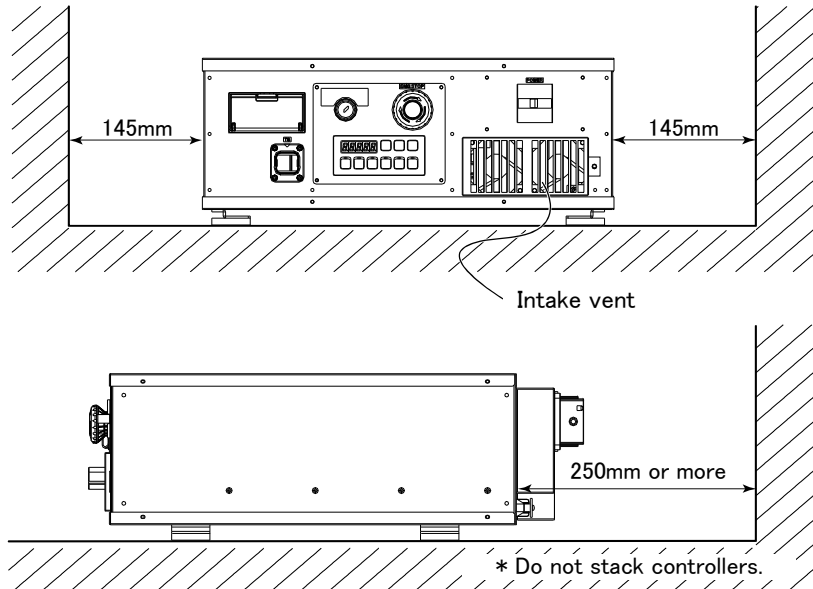

Fig.3-4 : Outside dimensions of controller (CR751)

### 3.3.2 Installation dimensions

#### (1) CR750 controller

<Placed horizontally>



<Placed vertically>

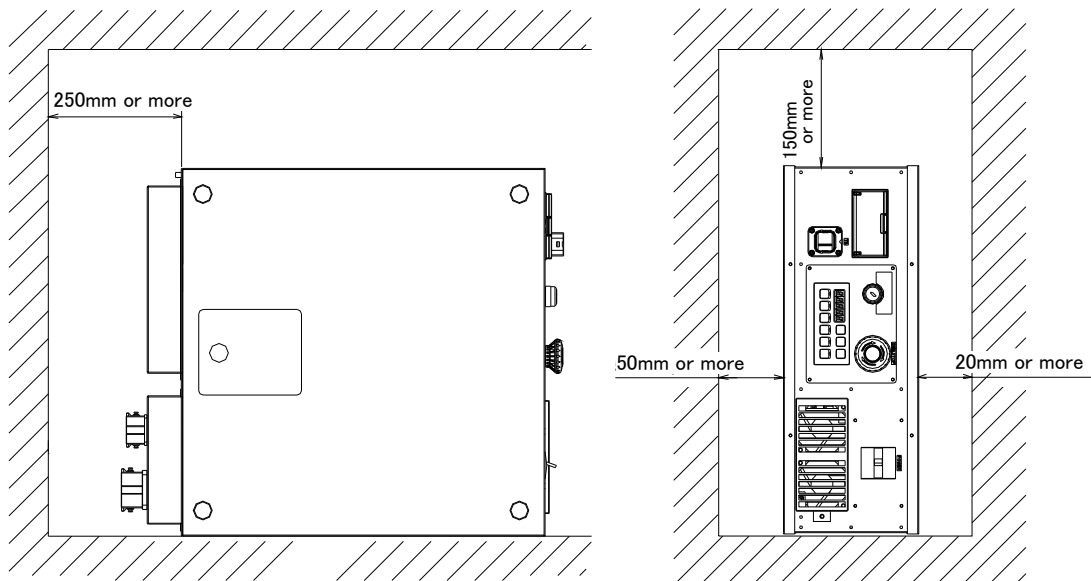

Fig.3-5 : Installation of controller (CR750)

#### ⚠ CAUTION

Fixing installation section sure for prevention from the fall, when using the controller placing vertically. The reference figure of the metal plate for fixing is shown in [Fig. 3-6](#). You should install the metal plate for fixation to the controller with M4 x 8 or the shorter screw. The screw projection length inside the controller (side board thickness is 1.2 mm) surely makes 6.8 mm or less.

#### ⚠ CAUTION

When storing the controller in a cabinet, etc., take special care to the heat radiating properties and ventilation properties so that the ambient temperature remains within the specification values. And, don't install the controller in the position where direct rays or the heat of lighting hits. The skin temperature of the controller may rise, and the error may occur.

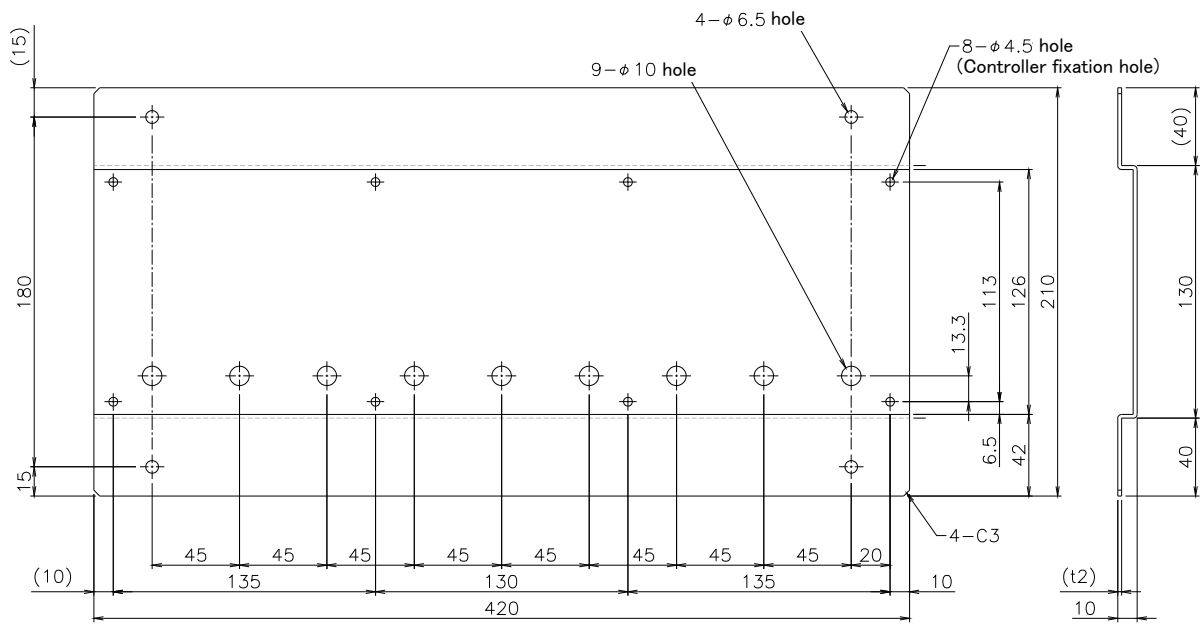
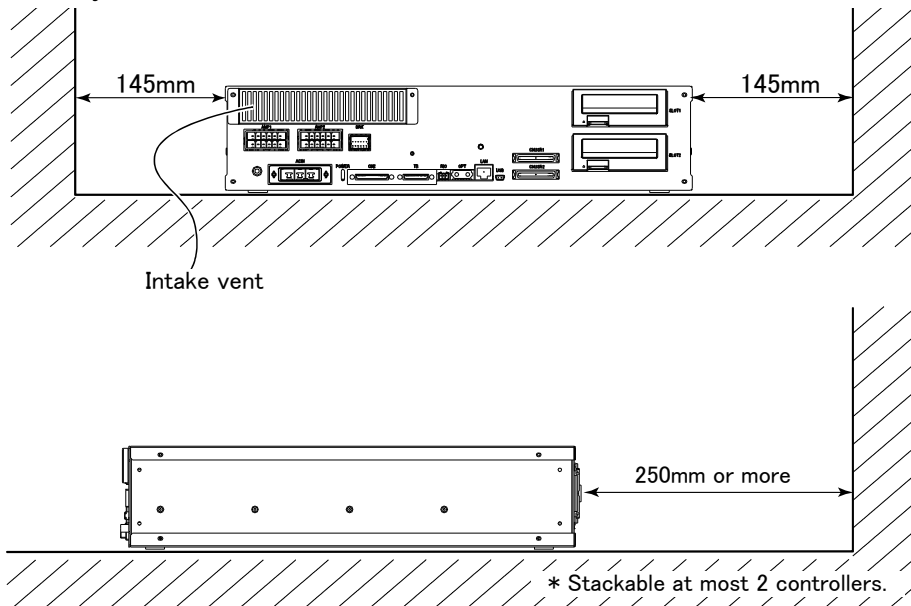

Fig.3-6 : Metal plate for fixation to placing vertically (Reference for CR750)

(2) CR751 controller

<Placed horizontally>



<Placed vertically>

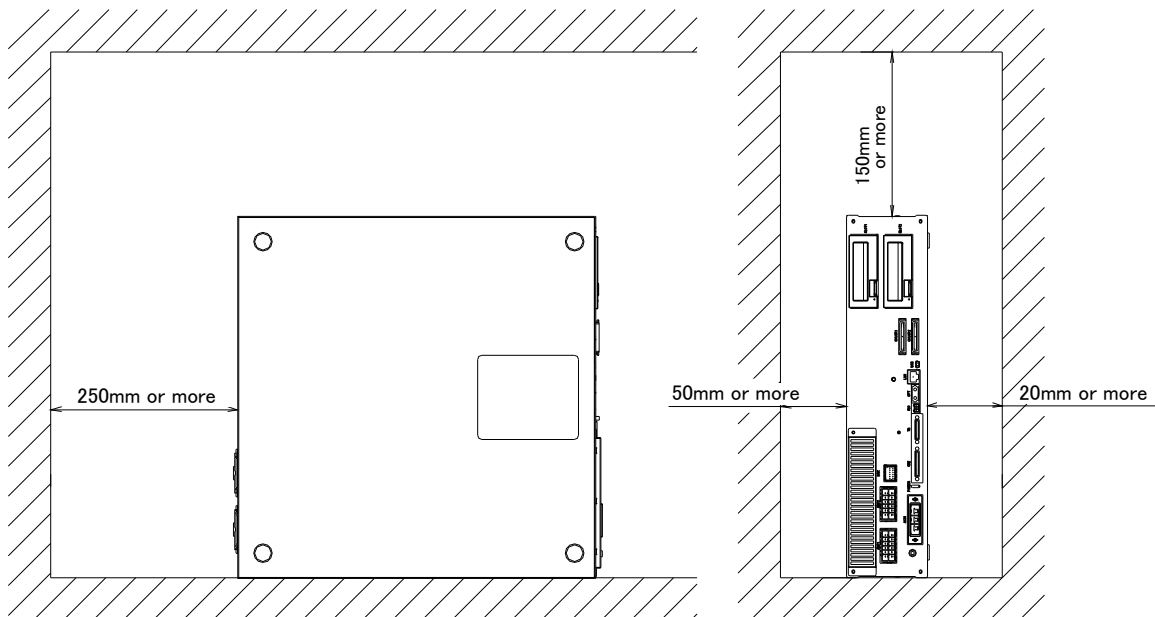

Fig.3-7 : Installation of controller (CR751)

**CAUTION**

Fixing installation section sure for prevention from the fall, when using the controller placing vertically. The reference figure of the metal plate for fixing is shown in Fig. 3-8. You should install the metal plate for fixation to the controller with M4 x 8 or the shorter screw. The screw projection length inside the controller (side board thickness is 1.2mm) surely makes 6.8mm or less.

**CAUTION**

When storing the controller in a cabinet, etc., take special care to the heat radiating properties and ventilation properties so that the ambient temperature remains within the specification values. And, don't install the controller in the position where direct rays or the heat of lighting hits. The skin temperature of the controller may rise, and the error may occur.

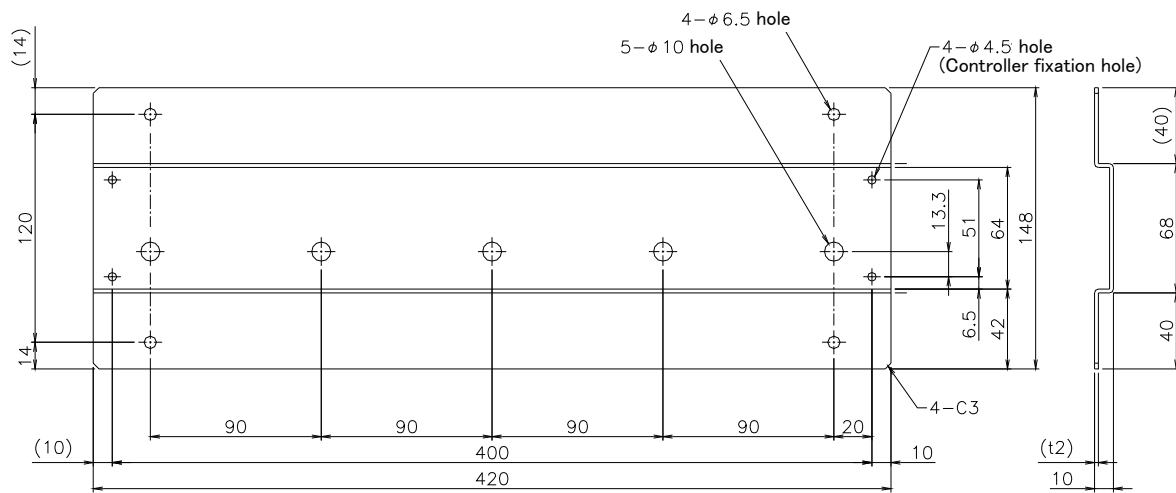

Fig.3-8 : Metal plate for fixation to placing vertically (Reference for CR751)

### 3.4 External input/output

#### 3.4.1 Types

- (1) Dedicated input/output..... These inputs and outputs carry out the robot remote operation and status display.
- (2) General-purpose input/output..... These are inputs and outputs that the customer can program for peripheral device control.
- (3) Hand input/output..... These are inputs and outputs related to the hand that the customer can program.
- (4)Emergency stop/Door switch input..... The wiring for the safe security of the emergency stop etc. is shown in on [Page 79, "3.6 Emergency stop input and output etc."](#) and on [Page 139, "6.1.7 Examples of safety measures"](#).

<For Reference>

Linking our GOT1000 Series (GT15) display equipment to the robot controller over the Ethernet permits you to control robot controller's input/output from a GOT (graphic operation terminal).



### 3.5 Dedicated input/output

Show the main function of dedicated input/output in the [Table 3-2](#). Refer to attached instruction manual “Detailed explanations of functions and operations” in the product for the other functions. Each parameter indicated with the parameter name is used by designated the signal No., assigned in the order of input signal No. and output signal No.

Table 3-2 : Dedicated input/output list

Parameter name	Input			Output	
	Name	Function	Level	Name	Function
TEACHMD	None			Teaching mode output signal	Outputs that the teaching mode is entered.
ATTOPMD	None			Automatic mode output signal	Outputs that the automatic mode is entered.
ATEXTMD	None			Remote mode output signal	Outputs that the remote mode is entered.
RCREADY	None			Controller power ON complete signal	Outputs that external input signals can be received.
AUTOENA	Automatic operation enabled input signal	Allows automatic operation.	L	Automatic operation enabled output signal	Outputs the automatic operation enabled state.
START	Start input signal	Starts all slots.	E	Operating output signal	Outputs that the slot is operating.
STOP	Stop input signal	Stops all slots. The input signal No. is fixed to 0. Note) Use the emergency stop input for stop inputs related to safety.	L	Wait output signal	Outputs that the slot is temporarily stopped.
STOP2	Stop input signal	The program during operation is stopped. Unlike the STOP parameter, change of the signal number is possible. Notes) Specification is the same as the STOP parameter.	L	Wait output signal	Outputs that the slot is temporarily stopped. Notes) Specification is the same as the STOP parameter.
SLOTINIT	Program reset input signal	Resets the wait state.	E	Program selection enabled output signal	Outputs that the slot is in the program selection enabled state.
ERRRESET	Error reset input signal	Resets the error state.	E	Error occurring output signal	Outputs that an error has occurred.
CYCLE	Cycle stop input signal	Carries out cycle stop.	E	In cycle stop operation output signal	Outputs that the cycle stop is operating.
SRVOFF	Servo ON enabled input signal	Turns the servo OFF for all mechanisms.	L	Servo ON enabled output signal	Outputs servo-on disable status. (Echo back)
SRVON	Servo ON input signal	Turns the servo ON for all mechanisms.	E	In servo ON output signal	Outputs the servo ON state.
IOENA	Operation rights input signal	Requests the operation rights for the external signal control.	L	Operation rights output signal	Outputs the operation rights valid state for the external signal control.
MELOCK	Machine lock input signal	Sets/resets the machine lock state for all mechanisms.	E	In machine lock output signal	Outputs the machine lock state.
SAFEPOS	Evasion point return input signal	Requests the evasion point return operation.	E	In evasion point return output signal	Outputs that the evasion point return is taking place.
OUTRESET	General-purpose output signal reset	Resets the general-purpose output signal.	E	None	
EMGERR	None			Emergency stop output signal	Outputs that an emergency stop has occurred.
S1START : S32START	Start input	Starts each slot.	E	In operation output	Outputs the operating state for each slot.

Parameter name	Input			Output	
	Name	Function	Level	Name	Function
S1STOP : S32STOP	Stop input	Stops each slot.	L	In wait output	Outputs that each slot is temporarily stopped.
PRGSEL	Program selection input signal	Designates the setting value for the program No. with numeric value input signals.	E	None	
OVRDSEL	Override selection input signal	Designates the setting value for the override with the numeric value input signals.	E	None	
IODATA Note2)	Numeric value input (start No., end No.)	Used to designate the program name, override value., mechanism value.	L	Numeric value output (start No., end No.)	Used to output the program name, override value., mechanism No.
PRGOUT	Program No. output request	Requests output of the program name.	E	Program No. output signal	Outputs that the program name is being output to the numeric value output signal.
LINEOUT	Line No. output request	Requests output of the line No.	E	Line No. output signal	Outputs that the line No. is being output to the numeric value output signal.
OVRDOUT	Override value output request	Requests the override output.	E	Override value output signal	Outputs that the override value is being output to the numeric value output signal.
ERROUT	Error No. output request	Requests the error No. output.	E	Error No. output signal	Outputs that the error No. is being output to the numeric value output signal.
JOGENA	Jog valid input signal	Validates jog operation with the external signals	E	Jog valid output signal	Outputs that the jog operation with external signals is valid.
JOGM	Jog mode input 2-bit	Designates the jog mode.	L	Jog mode output 2-bit	Outputs the current jog mode.
JOG+	Jog feed + side for 8-axes	Requests the + side jog operation.	L	None	
JOG-	Jog feed - side for 8-axes	Requests the - side jog operation.	L	None	
HNDCTRL1 : HNDCTRL3	None			Mechanism 1 hand output signal status : Mechanism 3 hand output signal status	Mechanism 1: Outputs the status of general-purpose outputs 900 to 907. Mechanism 2: Outputs the status of general-purpose outputs 910 to 917. Mechanism 3: Outputs the status of general-purpose outputs 920 to 927.
HNDSTS1 : HNDSTS3	None			Mechanism 1 hand input signal status : Mechanism 3 hand input signal status	Mechanism 1: Outputs the status of hand inputs 900 to 907. Mechanism 2: Outputs the status of hand inputs 910 to 917. Mechanism 3: Outputs the status of hand inputs 920 to 927.
HNDERR1 : HNDERR3	Mechanism 1 hand error input signal : Mechanism 3 hand error input signal	Requests the hand error occurrence.	L	Mechanism 1 hand error output signal : Mechanism 3 hand error output signal	Outputs that a hand error is occurring.

Parameter name	Input <small>Note1)</small>			Output	
	Name	Function	Level	Name	Function
AIRERR1 : AIRERR3	Pneumatic pressure error 1 input signal : Pneumatic pressure error 3 input signal	Request the pneumatic pressure error occurrence.	L	Pneumatic pressure error 1 output signal. : Pneumatic pressure error 3 output signal.	Outputs that a pneumatic pressure error is occurring.
M1PTEXC : M3PTEXC	None		L	Maintenance parts replacement time warning signal	Outputs that the maintenance parts have reached the replacement time.
USERAREA <small>Note3)</small>	None			User-designated area 8-points	Outputs that the robot is in the user-designated area.

Note1) The level indicates the signal level.

L: Level signal → The designated function is validated when the signal is ON, and is invalidated when the signal is OFF.

E: Edge signal → The designated function is validated when the signal changes from the OFF to ON state, and the function maintains the original state even when the signal then turns OFF.

Note2) Four elements are set in the order of input signal start No., end No., output signal start No. and end No.

Note3) Up to eight points can be set successively in order of start output signal No. and end output signal No.

### 3.6 Emergency stop input and output etc.

Do wiring of the external emergency stop, the special stop input, the door switch, and the enabling device from the "special input/output" terminal connector.

Table 3-3 : Special input/output terminal

Item	Name	Function
Input	Emergency stop	Applies the emergency stop. Dual emergency line
Input	Special stop input	Applies the stop. (Refer to <a href="#">Page 87, "3.6.2 Special stop input (SKIP)"</a> )
Input	Door switch	Servo-off. Dual line, normal close ( <a href="#">Page 89, "3.6.3 Door switch function"</a> )
Input	Enabling device	Servo-off. Dual line, normal close ( <a href="#">Page 89, "3.6.4 Enabling device function"</a> )
Output	Robot error output	Contact is opening during error occurrence.
Output	Emergency stop output	The point of contact opens under occurrence of emergency stop of external input signal, emergency stop of OP, emergency stop of T/B.
Output	Mode output	MANUAL mode: contactor is opening, AUTOMATIC mode: contactor is closing.
Output	Magnet contactor control connector output for addition axes	When an additional axis is used, the servo ON/OFF status of the additional axis can be synchronized with the robot arm. ( <a href="#">Page 97, "3.9 Magnet contactor control connector output (AXMC) for addition axes"</a> )

\*At the time of the power supply OFF, the output point of contact is always open.

[Note] The contact capacity of each input/output terminal is DC24V/10mA – 100mA. Don't connect the equipment except for this range. The use exceeding contact capacity causes failure. In the customer's system, do not ground the + side of 24V power supply prepared by customer for connect to the controller. (related with emergency stop and parallel input/output) If it connects with the controller under the condition that the + side is grounded, it will lead to failure of controller.

Pin number assignment of each terminal and the circuit diagram are shown in [Fig. 3-14 \(CR750\)](#) or [Fig. 3-13 \(CR751\)](#).

#### 3.6.1 Connection of the external emergency stop

The external emergency stop input and door switch input and enabling device input are opened at shipment as shown in [Fig. 3-14 \(CR750\)](#) or [Fig. 3-13 \(CR751\)](#).

Connect the external emergency stop switch and door switch with the following procedure.

And, the example of the connection and notes of the emergency stop are described in [Page 139, "6.1.7 Examples of safety measures"](#) Refer to it together

[Caution] The emergency stop circuit is duplicated inside the controller. The emergency stop switch uses a double contact-type switch, so please be sure to fix both of the contacts to the connector pins as shown below in order to ensure the wiring is duplicated. An error will continue to occur in the event that only one of the pins is connected.

1) Please prepare the emergency stop switch, door switch and enabling device.

a) External emergency switch

- CR750 controller.....CNUSR11 connector "between 3 and 4" and CNUSR12 Connector "between 3 and 4".
- CR751 controller.....CNUSR1 connector "between 2 and 27" and "between 7 and 32".

b) Door switch

- CR750 controller.....CNUSR11 connector "between 7 and 8" and CNUSR12 connector "between 7 and 8".
- CR751 controller.....CNUSR1 connector "between 4 and 29" and "between 9 and 34".

c) Enabling device

- CR750 controller.....CNUSR11 connector "between 9 and 10" and CNUSR12 connector "between 9 and 10".
- CR751 controller.....CNUSR1 connector "between 5 and 30" and "between 10 and 35".

[Caution] Be sure to use a shield cable for the emergency stop wiring cable. And when operating in an environment that is easily affected by noise, be sure to fix the attached ferrite core (model number: E04SR301334, manufacturer: Seiwa Electric Mfg. Co., Ltd.). Be sure to place the ferrite core more than 30 cm from the connecting terminal section.

**⚠ CAUTION** Make sure there are no mistakes in the wiring. Connecting differently to the way specified in the manual can result in errors, such as the emergency stop not being released. In order to prevent errors occurring, please be sure to check that all functions (such as the teaching box emergency stop, customer emergency stop, and door switch) are working properly after the wiring setup is completed.

**⚠ CAUTION** You should always connect doubly connection of the emergency stop, the door switch, and the enabling switch. In connection of only one side, if the relay of customer use should break down, it may not function correctly. And, the output contacts from the robot controller (robot error output, emergency stop output, mode output, addition axis contactor control output) are dual contacts (synchronizes). You should connect surely by dual line with the customer's equipment as well as connection of the emergency stop and the door switch.

**⚠ CAUTION** Please make sure to wire the multiple emergency stop switches so that they each function independently. Check and make sure that the emergency stop doesn't only function under an AND condition (when multiple emergency stop switches are ON at the same time).

(1) CR750 controller

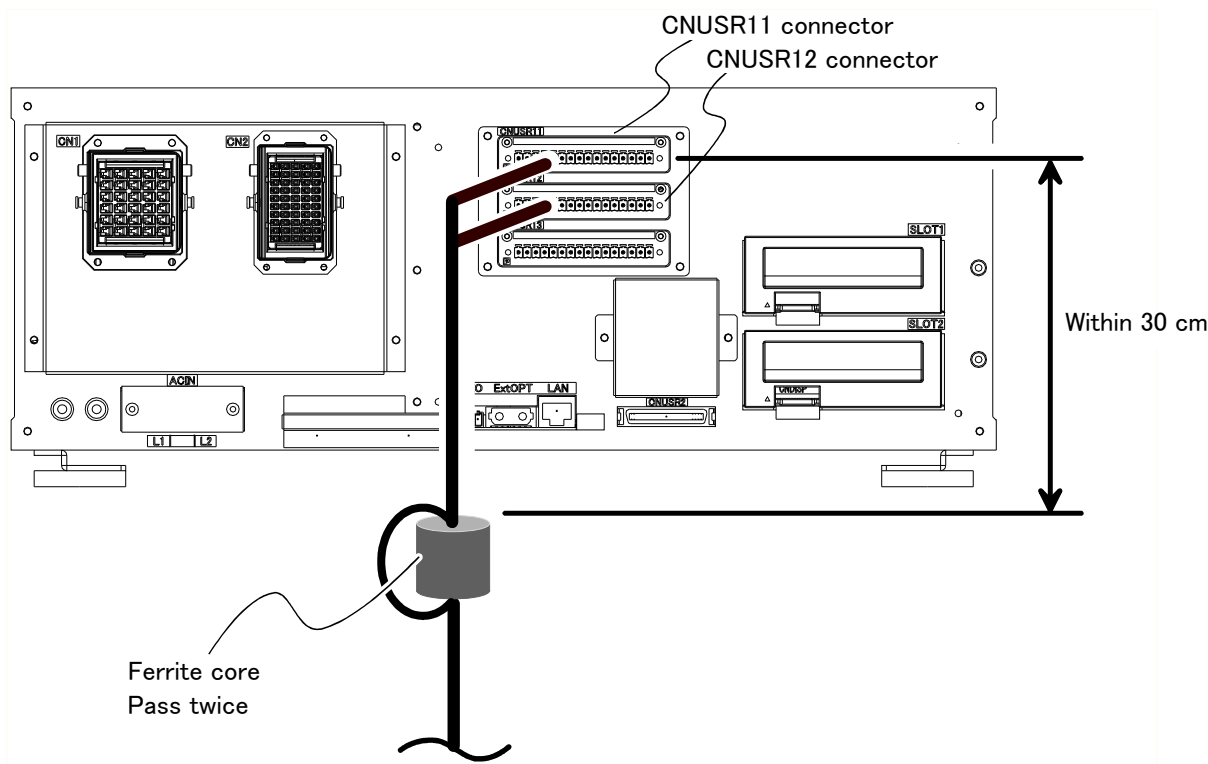

Fig.3-9 : Emergency stop cable connection (CR750)

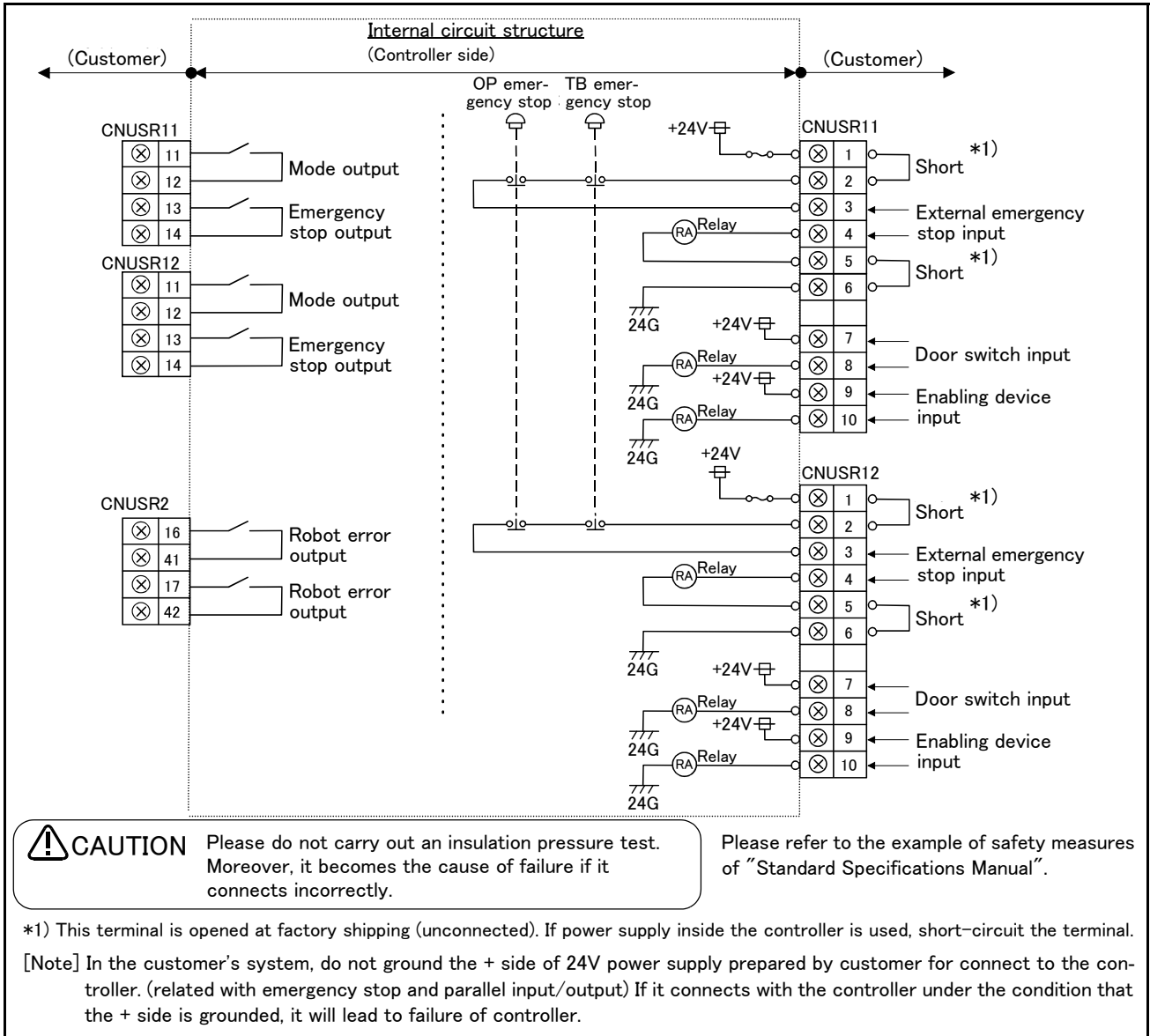

Fig.3-10 : External emergency stop connection (CR750)

**CAUTION**

Place the emergency stop switch in an easily operable position, and be sure to wire it to the emergency stop correctly by referencing [Page 139, "6.1.7 Examples of safety measures"](#).

This is a necessary measure in order to ensure safe operation so that the robot can be stopped immediately by pressing the emergency stop switch in the event that the robot malfunctions.

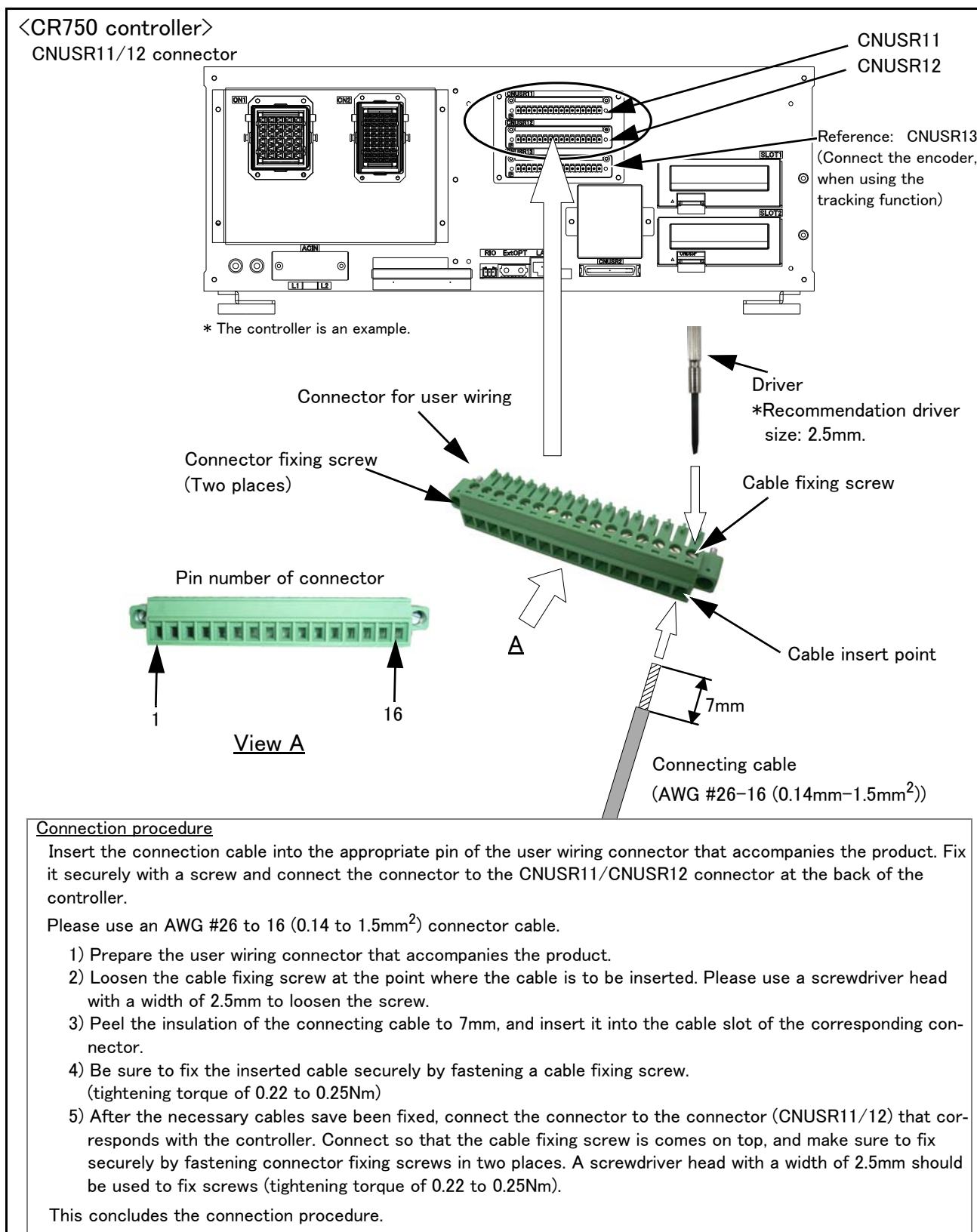

Fig.3-11 : Method of wiring for external emergency stop connection (CR750 (CNUSR11/12))

## ⚠ CAUTION

Makes sure that there is no mistake when connecting to the target connectors. Connecting incorrectly will result in the robot breaking down or malfunctioning. The connector on the controller side that connects to the user wiring connector is CNUSR11 or CNUSR12. Be careful not to connect to CNUSR13 as the robot will not operate properly.

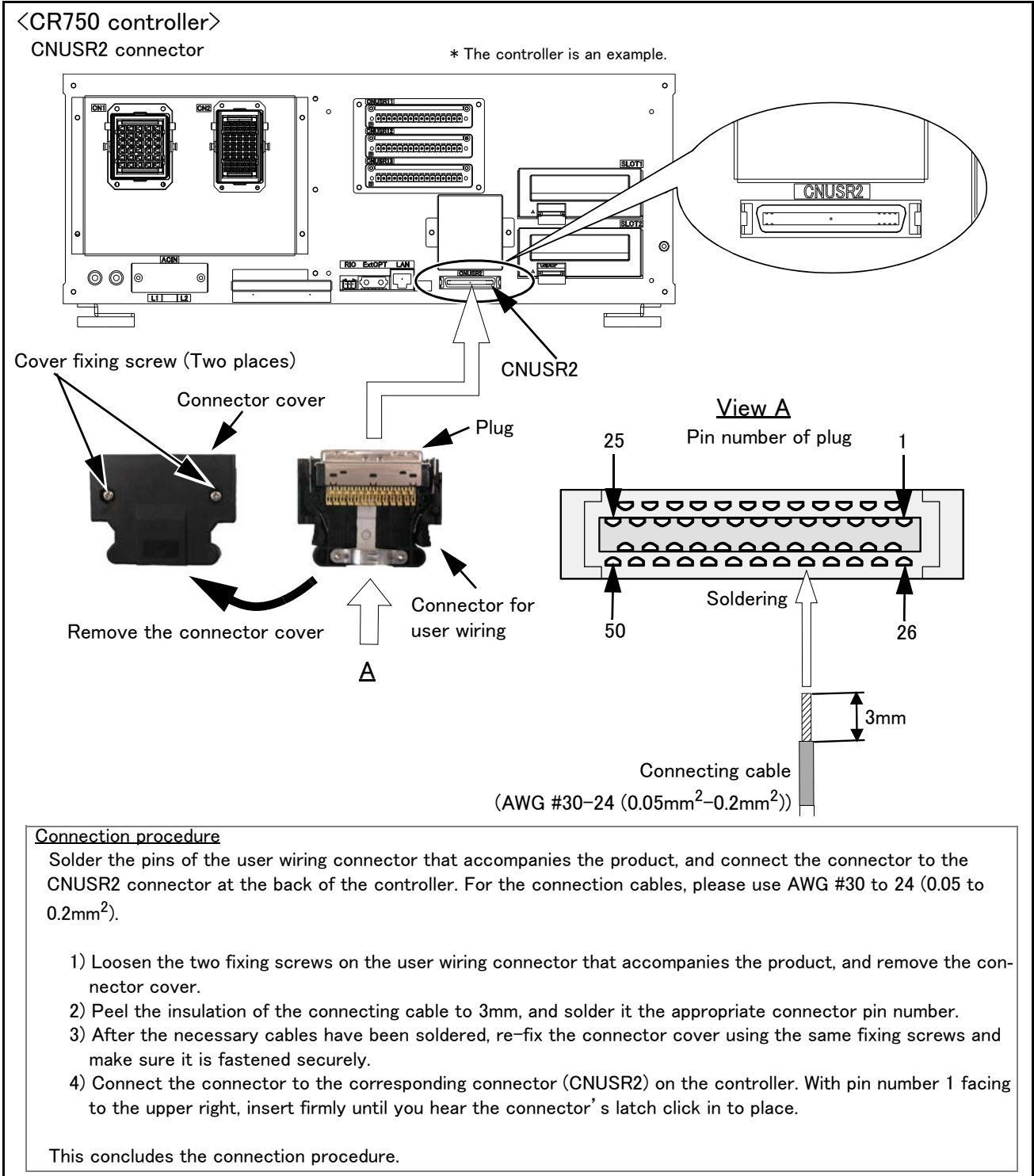

Fig.3-12 : Method of wiring for external emergency stop connection (CR750 (CNUSR2))

**CAUTION**

When soldering please take care to only connect to the specified pin number. Connecting to a different pin number or short-circuiting with another pin will result in the robot breaking down or malfunctioning.



## (2) CR751 controller

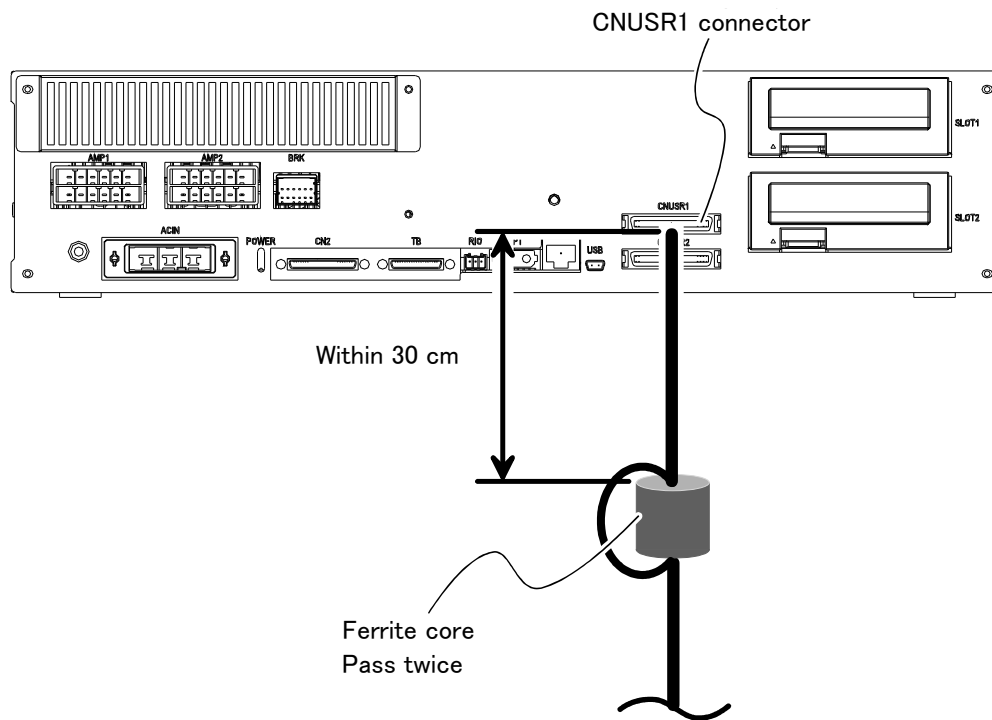

Fig.3-13 : Emergency stop cable connection (CR751)

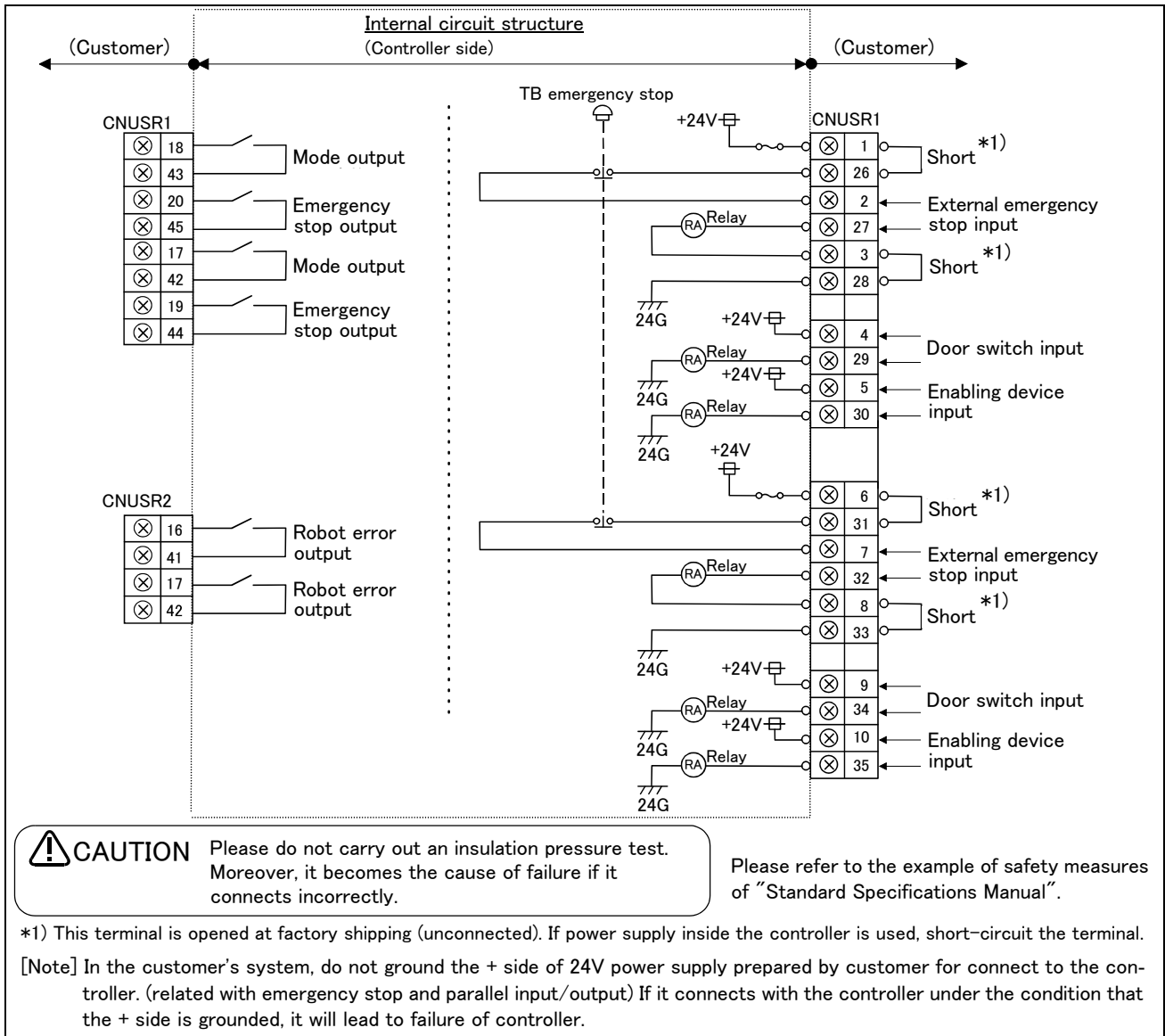

Fig.3-14 : External emergency stop connection (CR751)

**CAUTION**

Place the emergency stop switch in an easily operable position, and be sure to wire it to the emergency stop correctly by referencing [Page 139, "6.1.7 Examples of safety measures"](#).

This is a necessary measure in order to ensure safe operation so that the robot can be stopped immediately by pressing the emergency stop switch in the event that the robot malfunctions.

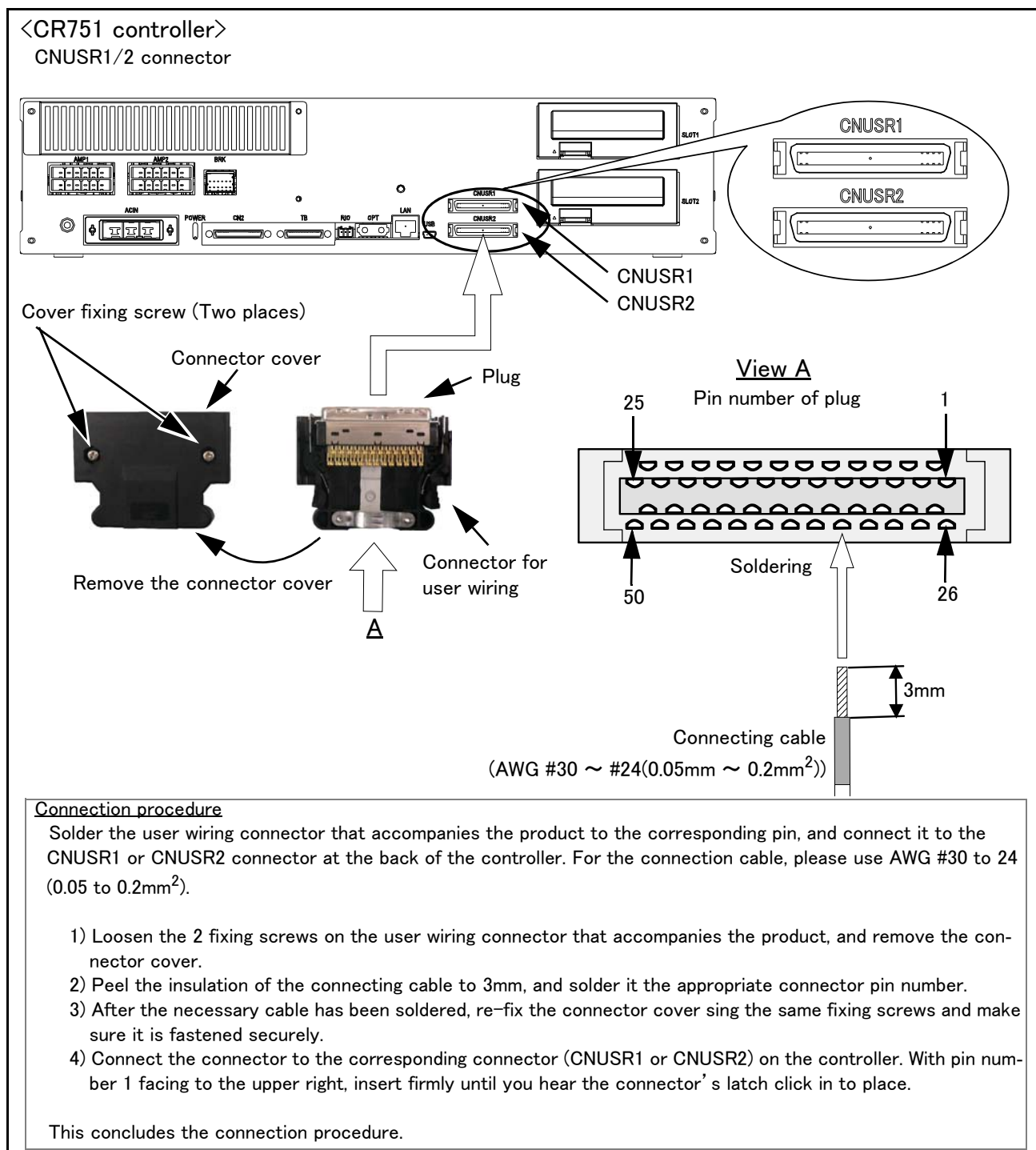

Fig.3-15 : Method of wiring for external emergency stop connection (CR751 (CNUSR1/2))

**CAUTION**

When soldering please take care to only connect to the specified pin number. Connecting to a different pin number or short-circuiting with another pin will result in the robot breaking down or malfunctioning.

The connectors on the controller side are CNUSR1 (upper side) and CNUSR2 (lower side). Make sure that there is no mistake when connecting to the target connectors. Connecting incorrectly will result in the robot breaking down or malfunctioning.

3.6.2 Special stop input (SKIP)

The skip is the input signal to stop the robot. The pin 9, 34 of the CNUSR2 connector shown in Fig. 3-16 (CR750) or Fig. 3-17 (CR751).

Table 3-4 : Special stop input electric specification

Item		Specifications	Internal circuit
Type		DC input	
No. of input point		1	
Insulation method		Photo-coupler insulation	
Rated input voltage		DC24V	
Rated input current		Approx. 11mA	
Working voltage range		DC 21.6 ~ 26.4V (Ripple rate within 5%)	
ON voltage/ON current		DC 8V or more / 2mA or more	
OFF voltage/OFF current		DC 4V or less / 1mA or less	
Input resistance		Approx. 2.2 k Ω	
Response time	OFF → ON	1ms or less	
	ON → OFF	1ms or less	
Common method		1 point per common	
External wire connection method		Connector	

(1) CR750 controller

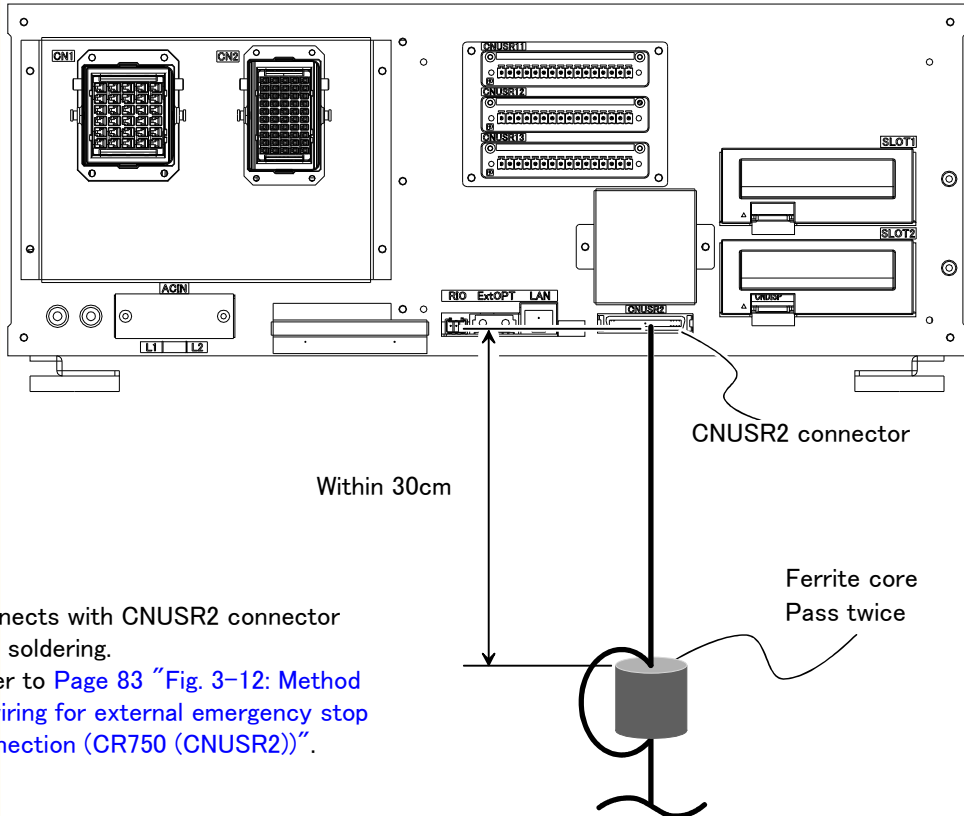

\* Connects with CNUSR2 connector with soldering.  
Refer to Page 83 "Fig. 3-12: Method of wiring for external emergency stop connection (CR750 (CNUSR2))".

Note) In the customer's system, do not ground the + side of 24V power supply prepared by customer for connect to the controller. (related with emergency stop and parallel input/output) If it connects with the controller under the condition that the + side is grounded, it will lead to failure of controller.

Fig.3-16 : Connection of the special-stop-input (CR750)

## (2) CR751 controller

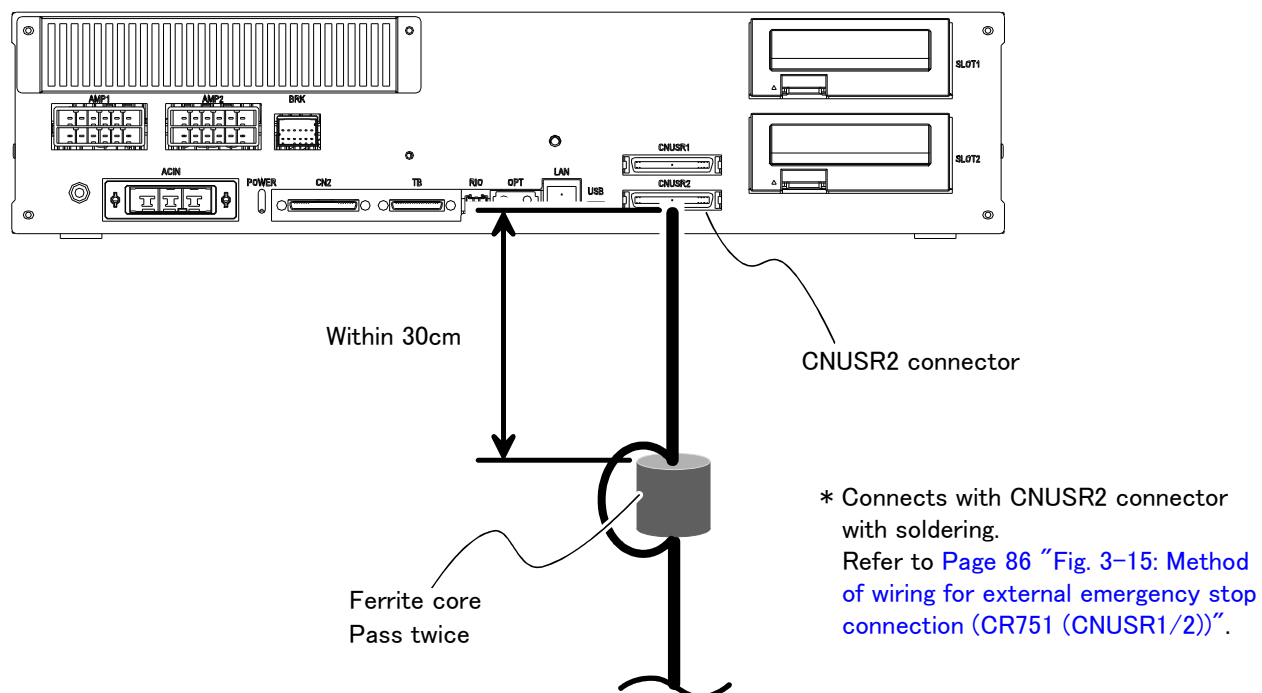

Note) In the customer's system, do not ground the + side of 24V power supply prepared by customer for connect to the controller. (related with emergency stop and parallel input/output) If it connects with the controller under the condition that the + side is grounded, it will lead to failure of controller.

Fig.3-17 : Connection of the special-stop-input (CR751)

### 3.6.3 Door switch function

This function retrieves the status of the switch installed on the door of the safety fence, etc., and stops the robot when the door is opened. This differs from an emergency stop in that the servo turns OFF when the door is opened and an error does not occur. Follow the wiring example shown in Page 85 "Fig. 3-14: External emergency stop connection (CR751)" or Page 84 "Fig. 3-13: Emergency stop cable connection (CR751)", and Page 139, "6.1.7 Examples of safety measures". Those figure explains the wire is contact closes when the door is closed. Details of this function according to the robot status are shown below.

- \*During automatic operation .....When the door is opened, the servo turns OFF and the robot stops. An error occurs.  
The process of the restoration: Close the door, reset the alarm, turn on the servo, and restart
- \*During teaching.....Even when the door is opened, the servo can be turned ON and the robot moved using the teaching pendant.

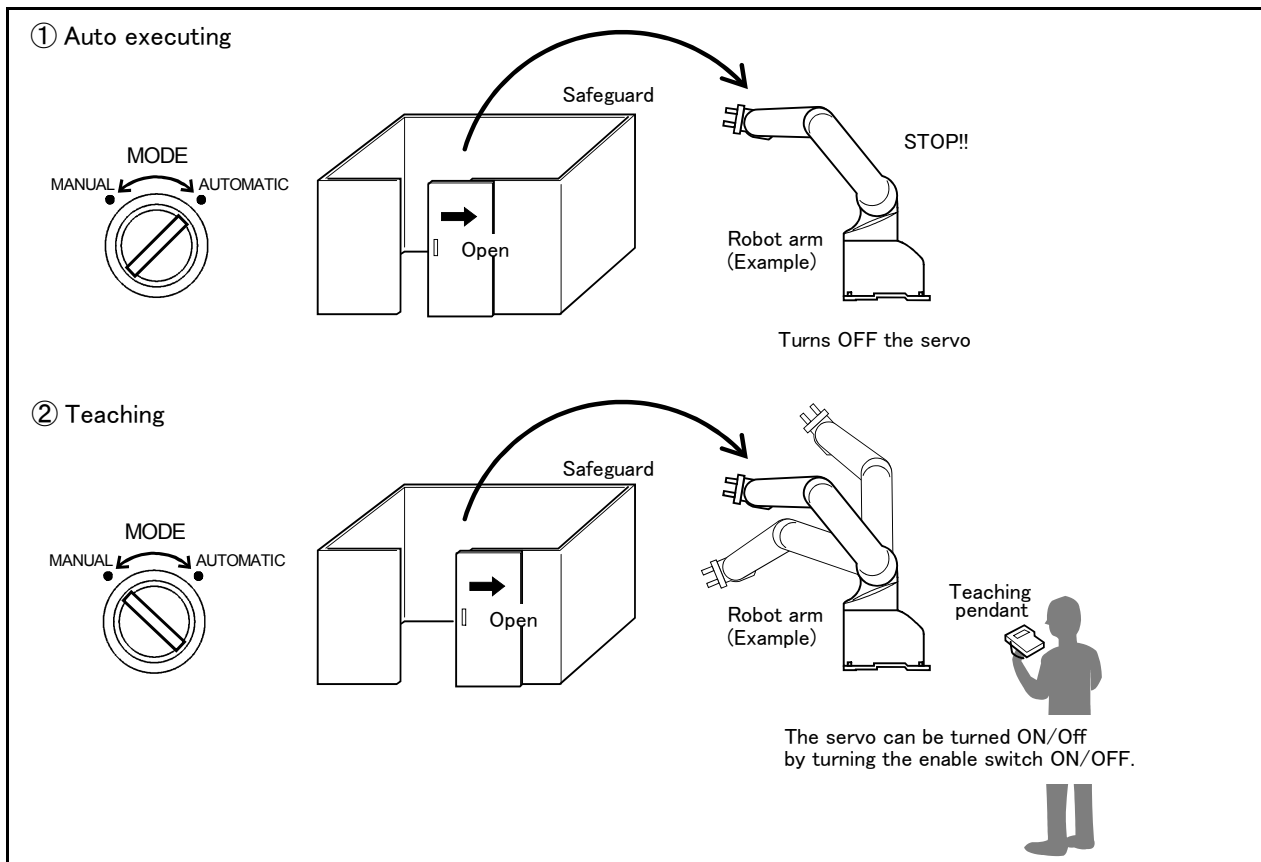

Fig.3-18 : Door switch function

### 3.6.4 Enabling device function

When the abnormalities occur in teaching operations etc., the robot's servo power can be immediately cut only by switch operation of the enabling device\*1) (servo-off), and the safety increases. To use the robot safely, please be sure to connect the enabling device.

#### (1) When door is opening

Please do teaching by two-person operations. One person has T/B, the other has enabling device. Turn on the servo power, in the condition that both of switches are pushed. (Enable switch of T/B and enabling device) Then the jog operation will be available. You can off the servo power only by releasing the switch of the enabling device. And, care that the servo-on and releasing the brake cannot be done in the condition that the switch of the enabling device is released.

\*1) Recommendation products: HE1G-L20MB (IDEC)

## (2) When door is closing

You can turn on the servo power by operation of only T/B. In this case perform jog operation outside the safeguard sure.

## (3) Automatic Operation/Jog Operation/Brake Release and Necessary Switch Settings

The following is a description of various operations performed on the robot and switch settings that are required.

Table 3-5 : Various operations and necessary switch settings

No	Operation	Related switch settings <sup>Note1)</sup>					Description
		Mode of controller	T/B enable/disable	T/B enable switch	Enabling device input terminal	Door switch input terminal	
1	Jog operation	Manual	Enable	ON	Close(ON)	—	If the enabling device input is set to Close (On), the state of door switch input does not matter.
2	Jog operation <sup>Note2)</sup>	Manual	Enable	ON	Open(OFF)	Close (Door Close)	If the enabling device input is set to Open (Off), door switch input must be in a state of Close
3	Brake release <sup>Note3)</sup>	Manual	Enable	ON	Close(ON)	—	Irrespective of the state of door switch input, enabling device input must be in a state of Close (On).
4	Automatic operation	Automatic	Disable	—	—	Close (Door Close)	Door switch input must always be in a state of Close (Door Close).

Note1) “—” in the table indicates that the state of switch concerned does not matter.

Refer to the following for operation of each switch.

- Mode of CR750 controller: .....Page 65, “3.2 Names of each part”
- Mode of CR751 controller: .....Page 91, “3.7 Mode changeover switch input”
- T/B enable/disable:.....Page 100, “(1) Teaching pendant (T/B)”
- T/B enable switch: .....Page 100, “(1) Teaching pendant (T/B)”
- Enabling device input terminal:.....Page 139, “6.1.7 Examples of safety measures”
- Door switch input terminal:.....Page 139, “6.1.7 Examples of safety measures”

Note2) Jog operation, if door switch input is set for Close (Door Close), must be performed outside the safety barrier.

Note3) It is imperative that brake release operation be carried out by two persons. One person turns on the enabling device (“Close” on the enabling device input terminal) while the other manipulates the T/B. Brake release can be effected only when both of the enabling switch device and the T/B enable switch are placed in intermediate position (lightly gripped position). At this point, the state of door switch input does not matter.

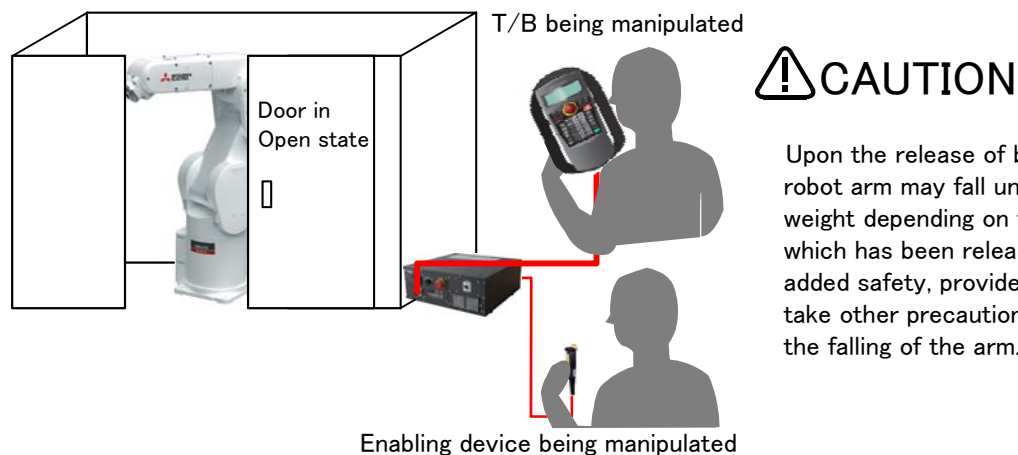

Fig.3-19 : Brake release operation

### 3.7 Mode changeover switch input

Connect the key switch of customer prepared and change the right of robot's operation by switch operation. The key switch can be installed in the operation panel of customer preparation.

<Right of operation (mode)>

**AUTOMATIC**.....The operation from external equipment becomes available. Operation which needs the right of operation from T/B cannot be performed. It is necessary to set the parameter for the rights of operation to connection with external equipment. Refer to the separate volume, "Instruction Manual/Detailed Explanation of Functions and Operations" for detail.

**MANUAL** .....When T/B is available, only the operation from T/B becomes available. Operation which needs the right of operation from external equipment cannot be performed.

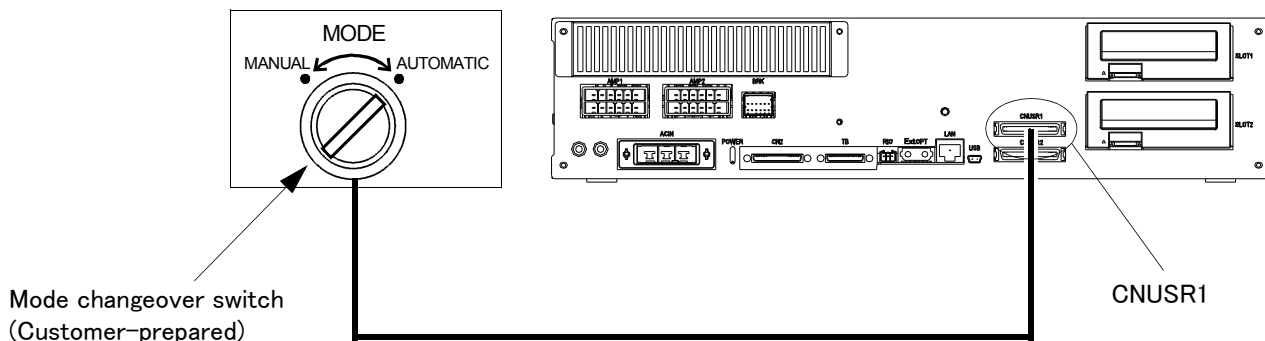

Fig.3-20 : Mode changeover switch image figure (CR751)

#### (1) Specification of the key switch interface

The function and specification of the key switch interface are shown below.

Table 3-6 : Function of the key switch interface

Pin number and Function (Connector: CNUSR1)		Change mode <sup>Note1)</sup>	
Pin number	Function	MANUAL	AUTOMATIC
49	1st line KEY input	Open	Close
24	Power supply +24V of pin number 49		
50	2nd line KEY input	Open	Close
25	Power supply +24V of pin number 50		

Note1) The mode changes by both opening or both closing between 30-5 pin and between 35-10 pin. Maintain the current mode except it.

[Note] In the customer's system, do not ground the + side of 24V power supply prepared by customer for connect to the controller. (related with emergency stop and parallel input/output) If it connects with the controller under the condition that the + side is grounded, it will lead to failure of controller.

Table 3-7 : Specification of the mode changeover switch input

Item	Specification	Remarks
Rated voltage	DC24V	Supply from the controller.
Current rating	Approx. 10mA	Select the switch or button which operates normally in 24V/10mA.
Input resistance	Approx. 2.2kΩ	
Response time (OFF->ON)	Approx. 15ms	Example: The response time the program starts, after pushing the run button.
Common method	1 point per common	
Connection method	Connector	
Conformity electric wire size	AWG#24 to #18	0.2 to 0.75mm <sup>2</sup>
Maker/Type	-	Maker: PHOENIX CONTACT/ Type: FKC2.5/4-STF-5.0B



## (2) Connection of the mode changeover switch input

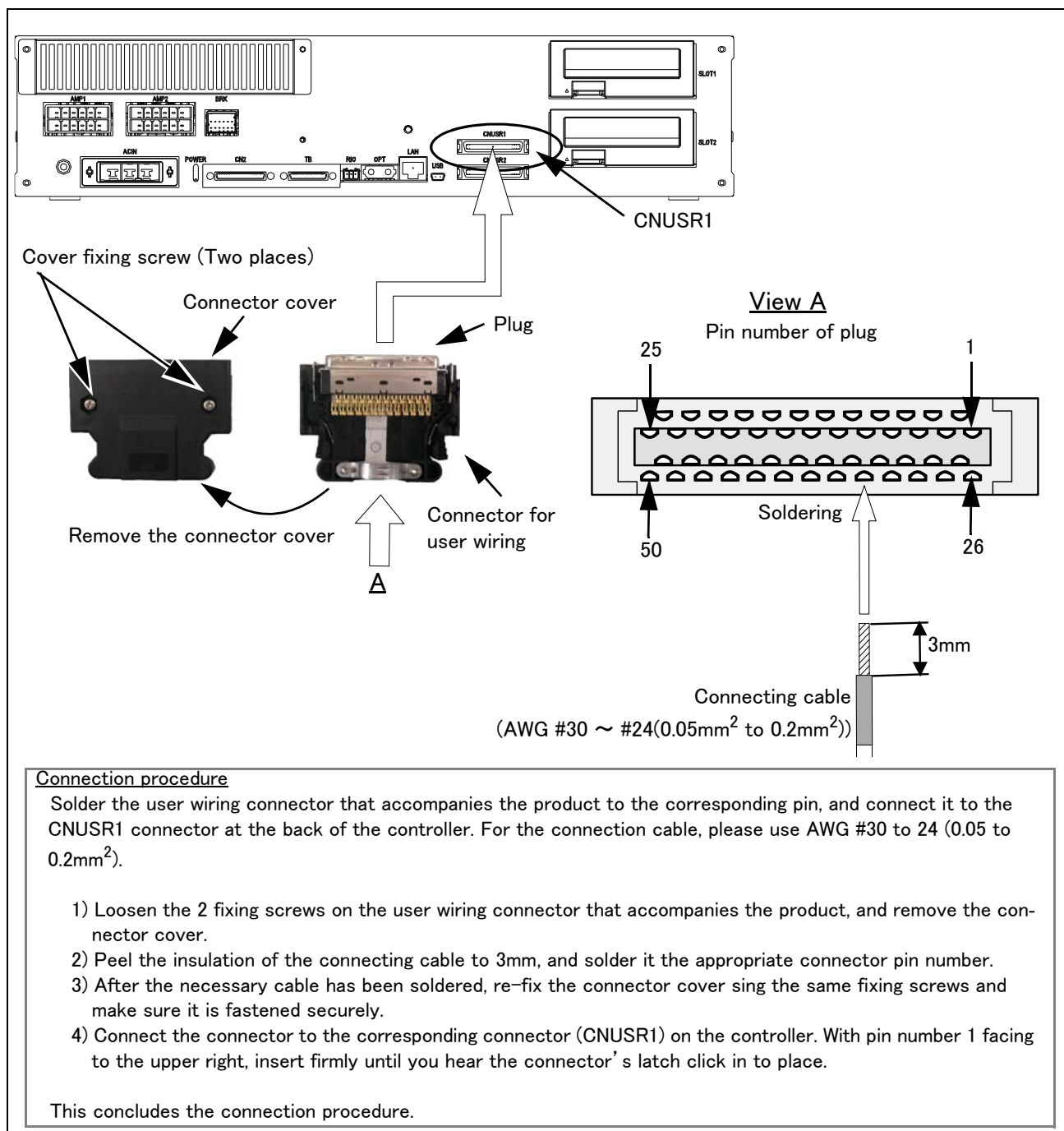

Fig.3-21 : Connection of the mode changeover switch input (CR751)

### 3.8 Additional Axis Function

This controller is equipped with an additional axis interface for controlling an additional axis when a traveling axis or rotary table is added to the robot. A maximum of eight axes of servo motors can be controlled at the same time by connecting a general-purpose servo amplifier (MR-J3-B, MR-J4-B series) that supports Mitsubishi's SSCNET III.

Refer to the separate "Additional axis interface Instruction Manual" for details on the additional axis function.

#### 3.8.1 Wiring of the Additional Axis Interface

Table 3-8 shows the connectors for additional axes inside the controller. Fig. 3-22 (CR750) and Fig. 3-23 (CR751) shows a connection example (configuration example).

Table 3-8 : Dedicated connectors inside the controller

Name	Connector name	Details
Connector for additional axes	ExtOpt	The connector for connecting the general-purpose servo amplifier.

#### (1) CR750 controller

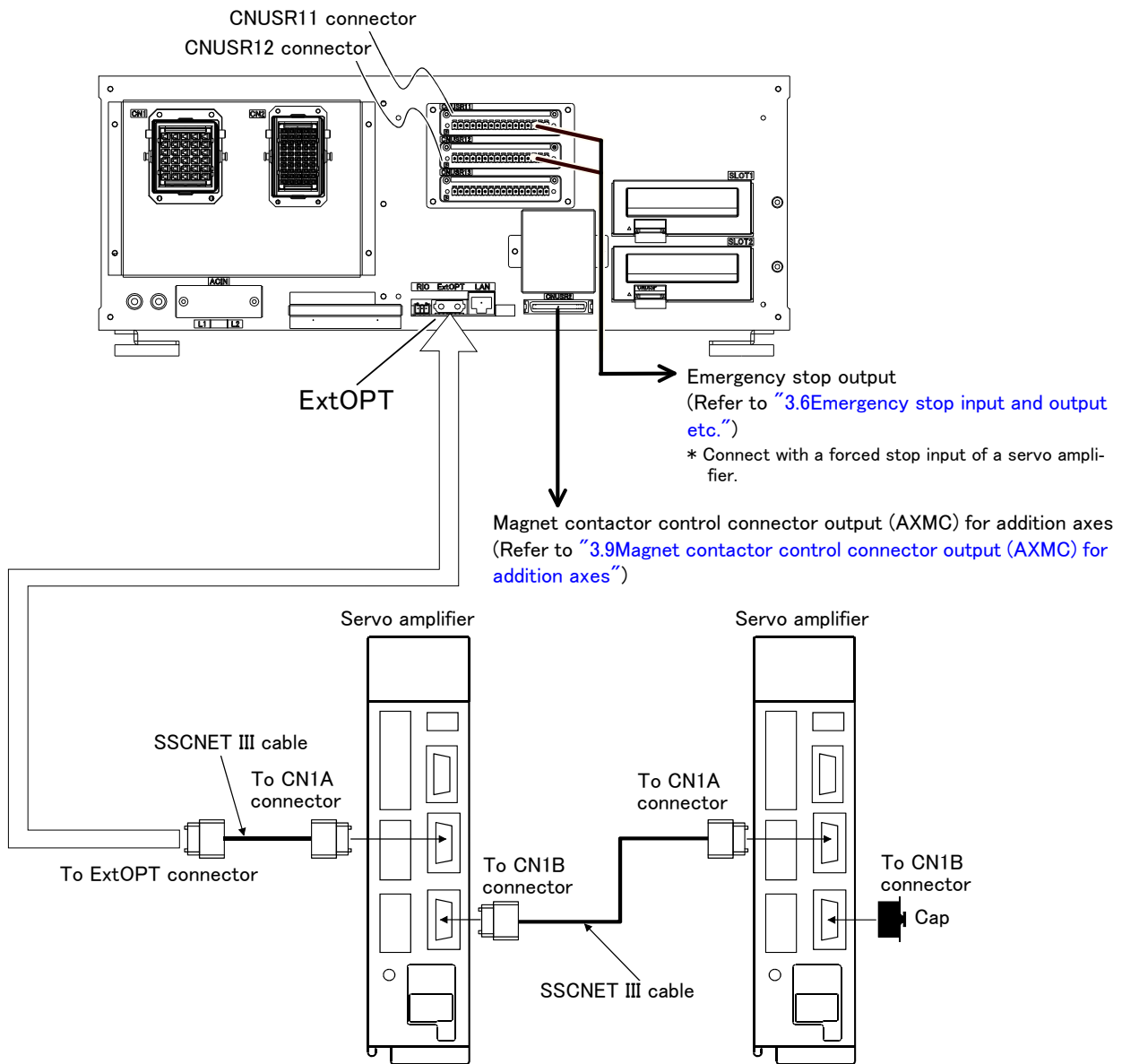

\* It cannot communicate, if connection of CN1A and CN1B is mistaken.

Fig.3-22 : Example of addition axis connection (CR750)

(2) CR751 controller

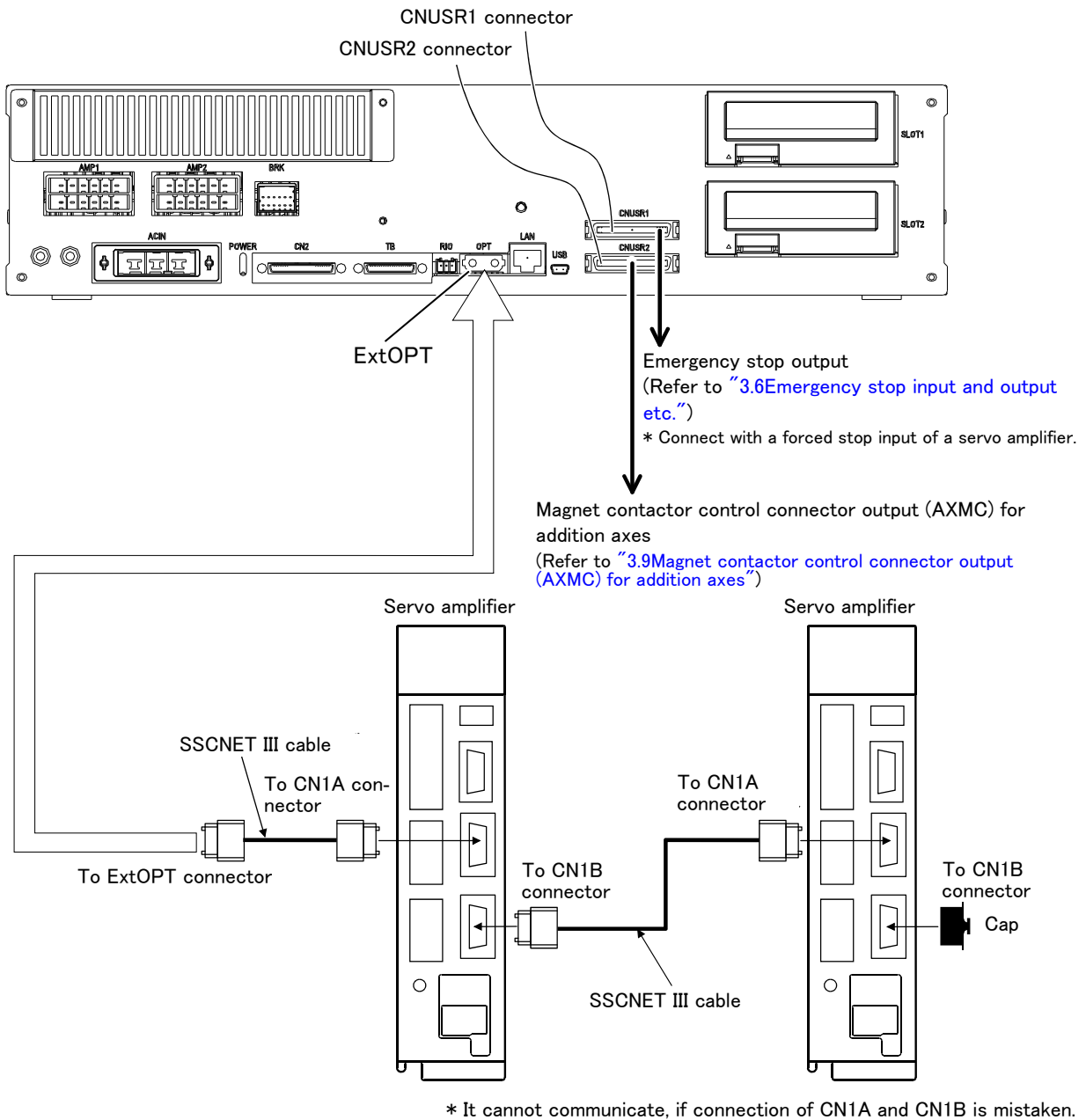

Fig.3-23 : Example of addition axis connection (CR751)

(3) Example of the installation of the noise filter

1) EMC filter (recommended)

Please install the recommendation filter shown below according to the example of connection.

1) Combination with the servo amplifier

Servo amplifier	Recommended filter (Soshin Electric)		Mass [kg]([lb])
	Model	Leakage current [mA]	
MR-J3-10B to MR-J3-100B MR-J3-10B1 to MR-J3-40B1	(Note) HF3010A-UN	5	3 (6.61)
MR-J3-250B ▪ MR-J3-350B	(Note) HF3030A-UN		5.5 (12.13)
MR-J3-500B ▪ MR-J3-700B	(Note) HF3040A-UN	1.5	6.0 (13.23)
MR-J3-11KB to MR-J3-22KB	(Note) HF3100A-UN	6.5	15 (33.07)
MR-J3-60B4 ▪ MR-J3-100B4	TF3005C-TX	5.5	6(13.23)
MR-J3-200B4 to MR-J3-700B4	TF3020C-TX		7.5(16.54)
MR-J3-11KB4	TF3030C-TX		12.5(27.56)
MR-J3-15KB4	TF3040C-TX		
MR-J3-22KB4	TF3060C-TX		

Note. A surge protector is separately required to use any of these EMC filters.

2) Connection example

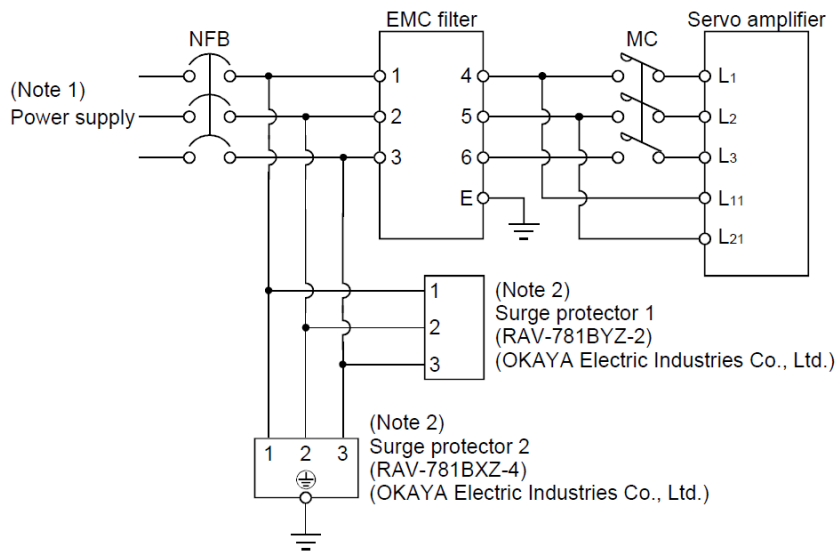

Note1) For 1-phase 200V to 230VAC power supply, connect the power supply to L1, L2 and leave L3 open.  
There is no L3 for 1-phase 100 to 120 VAC power supply.

Note2) The example is when a surge protector is connected.

Fig.3-24 : Example of EMC noise filter installation

2) Line noise filter

This filter is effective in suppressing noises radiated from the power supply side and output side of the servo amplifier and also in suppressing high-frequency leakage current (zero-phase current) especially within 0.5MHz to 5MHz band.

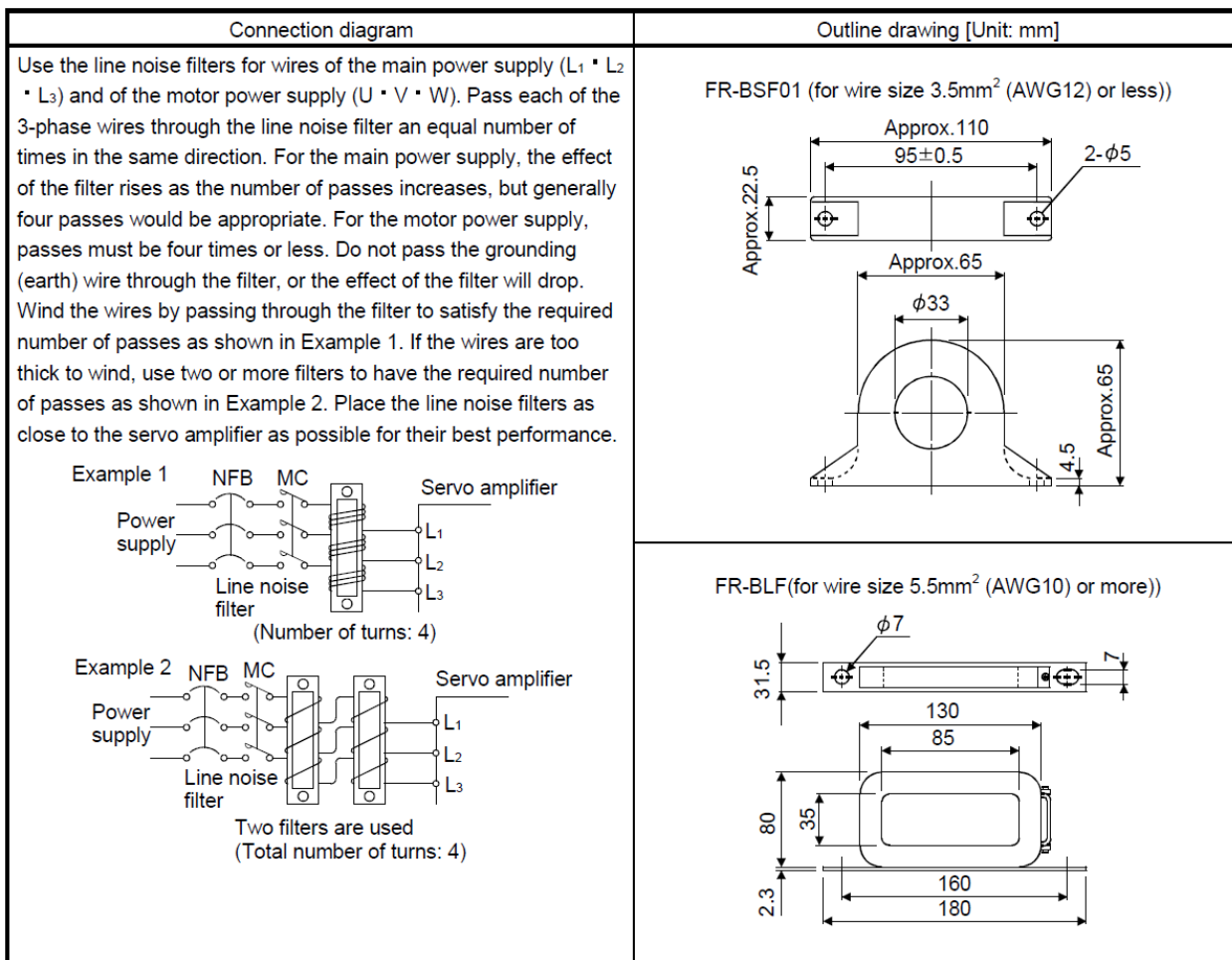

Fig.3-25 : Example of noise filter installation

### 3.9 Magnet contactor control connector output (AXMC) for addition axes

When an additional axis is used, the servo ON/OFF status of the additional axis can be synchronized with the servo ON/OFF status of the robot itself by using the output contact (AXMC) provided on the rear or inside of the controller and configuring a circuit so that the power to the servo amplifier for the additional axis can be turned off when this output is open.

An example circuit and an image of how to connect the controller connector are shown below. When you are using an additional axis, please perform appropriate circuit connections by referring to these drawings.

Refer to the separate "Additional axis interface Instruction Manual" for details on the additional axis function.

Note1) you use the addition axis function as a user mechanism who became independent of the robot arm, please do not connect this output signal. Servo-on of the user mechanism may be unable.

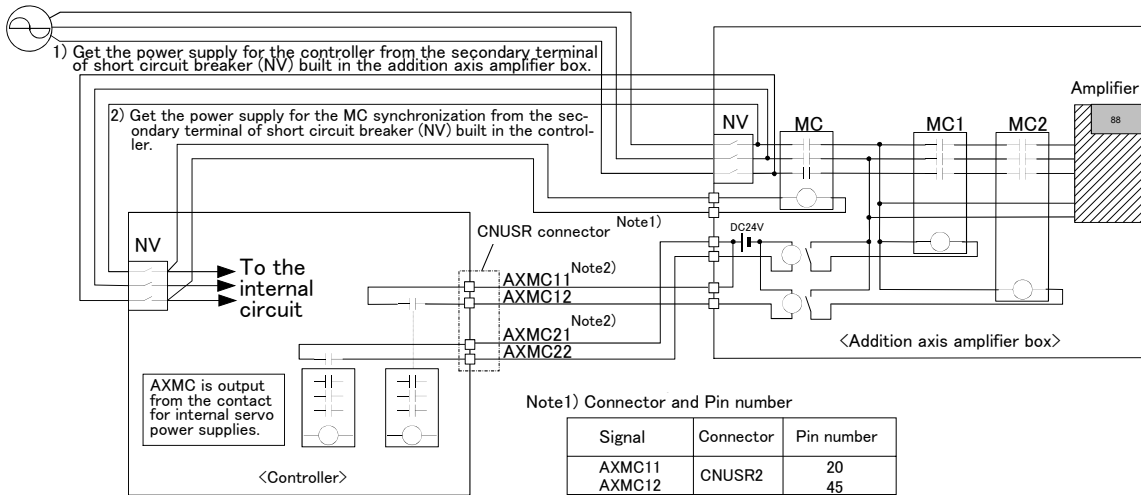

Note1) Connector and Pin number

Signal	Connector	Pin number
AXMC11	CNUSR2	20
AXMC12		45
AXMC21	CNUSR2	19
AXMC22		44

Note2) This output is opened, if the robot turns off the servo by occurrence of alarm etc.  
<Electric specification>  
DC24V/10mA to 100mA

[Note] In the customer's system, do not ground the + side of 24V power supply prepared by customer for connect to the controller. (related with emergency stop and parallel input/output) If it connects with the controller under the condition that the + side is grounded, it will lead to failure of controller.

Fig.3-26 : Example of circuit for addition axes of Magnet contactor control output

(1) CR750 controller

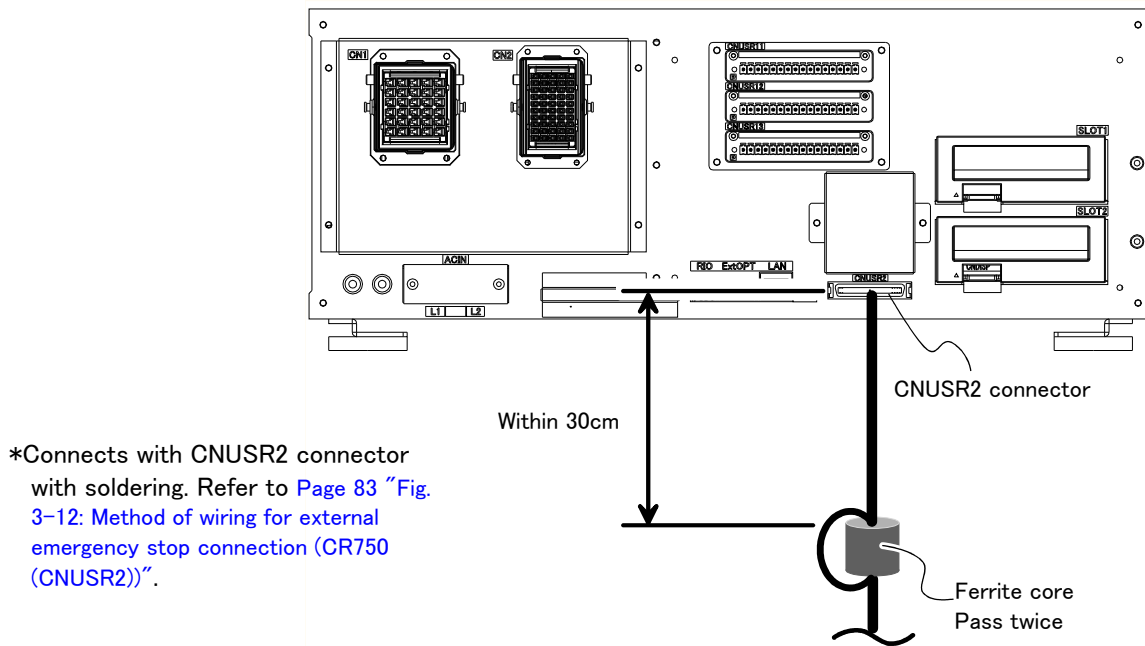

Fig.3-27 : AXMC terminal connector (CR750)

(2) CR751 controller

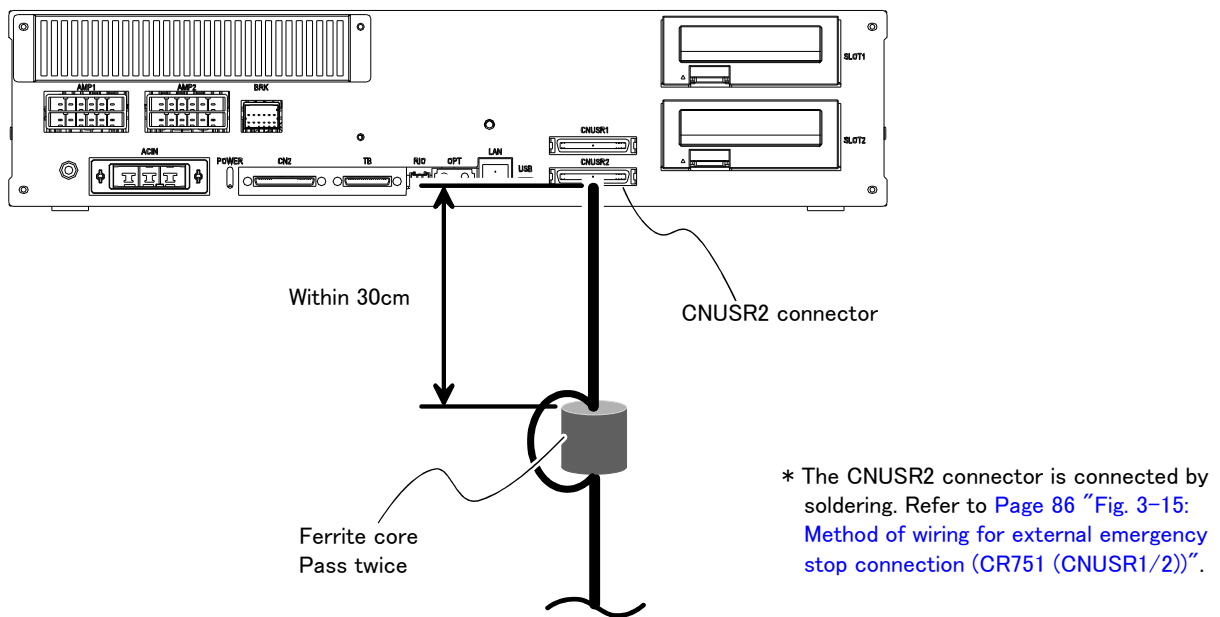

Fig.3-28 : AXMC terminal connector (CR751)

### 3.10 Options

■ What are options?

There are a variety of options for the robot designed to make the setting up process easier for user needs.

User installation is required for the options.

Options come in two types: "set options" and "single options".

1. Set options .....A combination of single options and parts that together, form a set for serving some purpose.
2. Single options .....That are configured from the fewest number of required units of a part. Please choose user's purpose additionally.



## (1) Teaching pendant (T/B)

- Order type: CR750 controller.....R32TB: Cable length 7m  
R32TB-15: Cable length 15m  
CR751 controller.....R33TB: Cable length 7m  
R33TB-15: Cable length 15m

## ■ Outline



This is used to create, edit and control the program, teach the operation position and for jog feed, etc.

For safety proposes, a 3-position enable switch is mounted.\*1)

## ■ Configuration

Table 3-9 : Configuration device

Part name	Type	Qty.	Mass (kg) <sup>Note1)</sup>	Remarks
CR750 controller				
Teaching pendant	R32TB	Either one pc.	1.7	Cable length is 7m. Hand strap is attached.
	R32TB-15		2.8	Cable length is 15m. Hand strap is attached.
CR751 controller				
Teaching pendant	R33TB	Either one pc.	1.7	Cable length is 7m. Hand strap is attached.
	R33TB-15		2.8	Cable length is 15m. Hand strap is attached.

Note1) Mass indicates one set.

## ■ Specifications

Table 3-10 : Specifications

Items	Specifications	Remarks
Outline dimensions	195(W) x 292(H) x 106(D) (refer to outline drawing)	
Body color	Dark gray	
Mass	Approx. 0.9kg (only arm, excluding cable)	
Connection method	Connection with controller and connector.	
Interface	RS-422	
Display method	LCD method: 24 characters x 8 lines, LCD illumination: with backlight	At 8x8 font
Operation section	36 keys	

## \*1) &lt;3-position enable switch&gt;

In ISO/10218 (1992) and JIS-B8433 (1993), this is defined as an "enable device". These standards specify that the robot operation using the teaching pendant is enabled only when the "enable device" is at a specified position. With the Mitsubishi Electric industrial robot, the above "enable device" is configured of an "Enable/Disable switch" and "Enable switch".

The 3-position enable switch has three statuses. The following modes are entered according to the switch state.

- a) "Not pressed" .....The robot does not operate. \*)
- b) "Pressed lightly" .....The robot can be operated and teaching is possible.
- c) "Pressed with force" .....The robot does not operate. \*)

\*) Operations, such as program editing and status display, other than robot operation are possible.

Safety is secured as the servo power is turned OFF simultaneously with the input of the emergency stop.

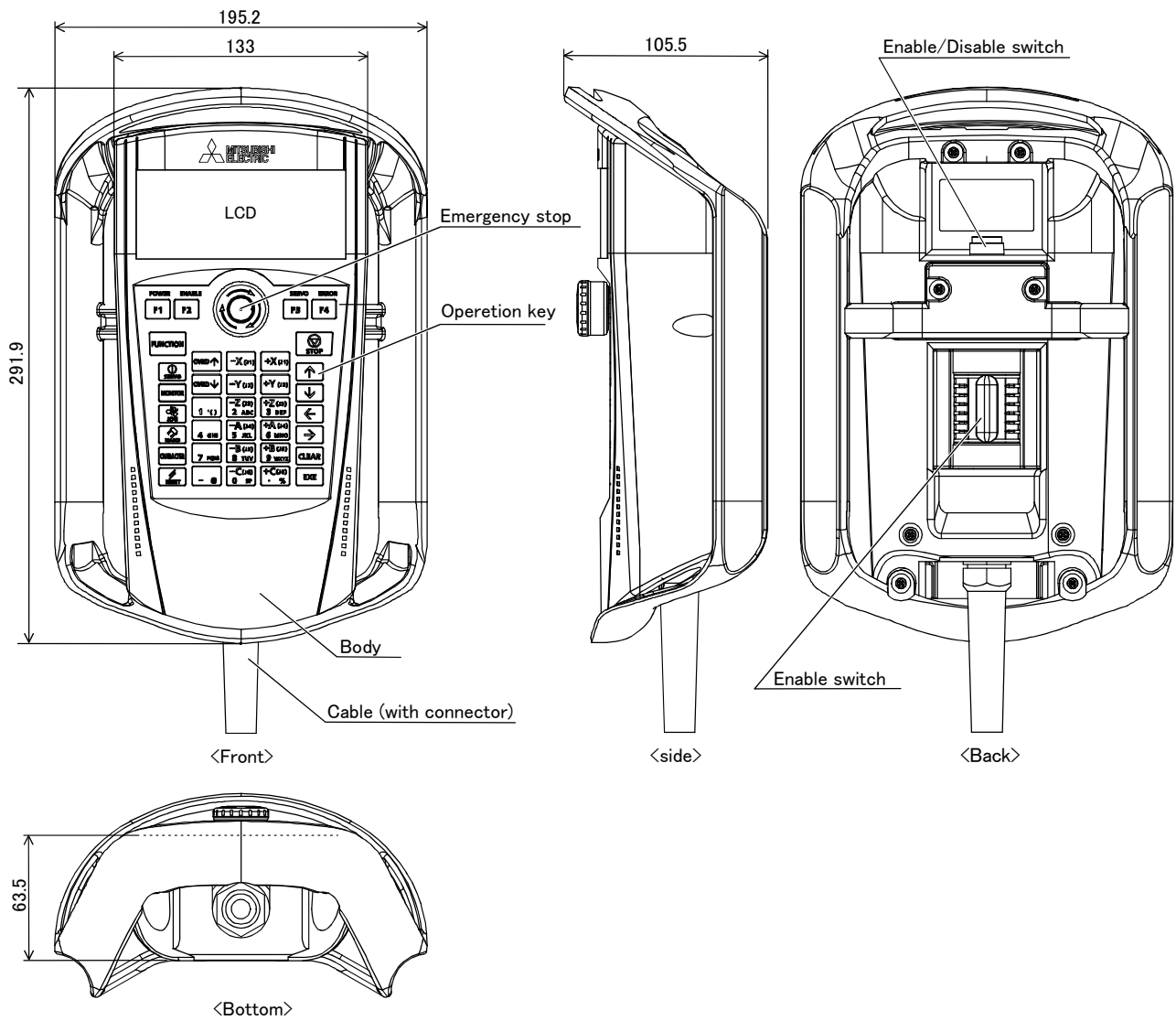

Fig.3-29 : Outside dimensions of teaching pendant

■ Installation method

The teaching pendant is connected to the T/B connector on the front of the controller.

### ■ Key layout and main functions



- ① [Emergency stop] switch..... The robot servo turns OFF and the operation stops immediately.
- ② [Enable/Disable] switch ..... This switch changes the T/B key operation between enable and disable.
- ③ [Enable] switch..... When the [Enable/Disable] switch “ ② ” is enabled, and this key is released or pressed with force, the servo will turn OFF, and the operating robot will stop immediately.
- ④ LCD display panel ..... The robot status and various menus are displayed.
- ⑤ Status display lamp ..... Display the state of the robot or T/B.
- ⑥ [F1], [F2], [F3], [F4]..... Execute the function corresponding to each function currently displayed on LCD.
- ⑦ [FUNCTION] key ..... Change the function display of LCD.
- ⑧ [STOP] key..... This stops the program and decelerates the robot to a stop.
- ⑨ [OVRD ↑ ][OVRD ↓ ] key ..... Change moving speed. Speed goes up by [OVRD ↑ ] key. Speed goes down by [OVRD ↓ ] key
- ⑩ [JOG] operation key ..... Move the robot according to jog mode. And, input the numerical value.
- ⑪ [SERVO] key ..... Press this key with holding AA key lightly, then servo power will turn on.
- ⑫ [MONITOR] key ..... It becomes monitor mode and display the monitor menu.
- ⑬ [JOG] key..... It becomes jog mode and display the jog operation.
- ⑭ [HAND] key..... It becomes hand mode and display the hand operation.
- ⑮ [CHARACTER] key..... This changes the edit screen, and changes between numbers and alphabetic characters.
- ⑯ [RESET] key..... This resets the error. The program reset will execute, if this key and the EXE key are pressed.
- ⑰ [ ↑ ][ ↓ ][ ← ][ → ] key..... Moves the cursor each direction .
- ⑱ [CLEAR] key ..... Erase the one character on the cursor position.
- ⑲ [EXE] key..... Input operation is fixed. And, while pressing this key, the robot moves when direct mode.
- ⑳ Number/Character key..... Erase the one character on the cursor position. And, inputs the number or character

Fig.3-30 : Teaching pendant key layout and main functions

(2) Parallel I/O interface

■ Order type : ● 2D-TZ368 (Sink type)/2D-TZ378 (Source type)

■ Outline



This is used to expand the external inputs and outputs

- The connecting cable with external equipment is not attached. Since we are preparing the external input-and-output cable (2D-CBL05 or 2D-CBL15) as the option, please use.

Notes)Although the combined use with the parallel input-and-output unit (2A-RZ361/2A-RZ371) of another option is also possible, please use the setup of the station number by the different number separately. The station number is automatically determined by the position of the option slot which installed this interface. (station number 0 to 1)

■ Configuration

Table 3-11 : Configuration device

Part name	Type	Qty.	Mass (kg) <sup>Note1)</sup>	Remarks
Parallel I/O interface	2D-TZ368	Either one pc.	0.4	Input/output 32 points/32 points 2D-TZ368 is sink type. 2D-TZ378 is source type.
	2D-TZ378			

Note1) Mass indicates one set.

■ Specifications

Table 3-12 : Electrical specifications of input circuits

Item	Specification		Internal circuit
Type	DC input		<p>&lt;Sink type&gt;</p> <p>&lt;Source type&gt;</p>
Number of input points	32		
Insulation method	Photo coupler insulation		
Rated input voltage	DC12V	DC24V	
Rated input current	Approx. 3mA	Approx. 9mA	
Working voltage range	DC10.2 ~ 26.4V (Ripple factor should be less than 5%)		
ON voltage/ON current	DC8V or more/2mA or more		
OFF voltage/ OFF current	DC4V or less/1mA or less		
Input resistance	Approx. 2.7k Ω		
Response time	OFF-ON	10ms or less(DC24V)	
	ON-OFF	10ms or less(DC24V)	
Common method	32 points per common		
External cable connection method	Connector		

Table 3-13 : Electrical specifications for the output circuits

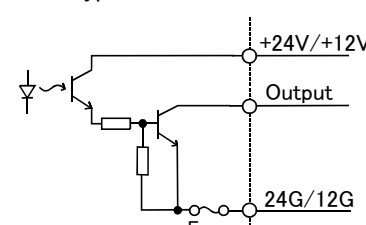
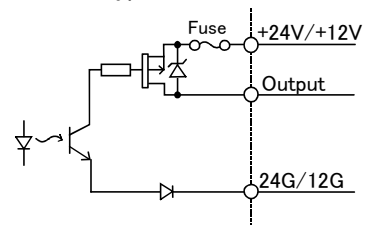
Item		Specification	Internal circuit
Type		Transistor output	<p>&lt;Sink type&gt;</p>  <p>&lt;Source type&gt;</p> 
No. of output points		32	
Insulation method		Photo-coupler insulation	
Rated load voltage		DC12V/DC24V	
Rated load voltage range		DC10.2 ~ 30V (peak voltage DC30V)	
Max. load current		0.1A/point (100%)	
Leakage current at OFF		Within 0.1mA	
Max. voltage drop at ON		DC0.9V(TYP.) <sup>Note1)</sup>	
Response time	OFF-ON	10ms or less(Resistance load) (hardware response time)	
	ON-OFF	10ms or less(Resistance load) (hardware response time)	
Fuse rating		Fuse 1.6A(one per common) Replacement possible (max. 3)	
Common method		16 points per common (common terminal: 2points)	
External wire connection method		Connector	
External power supply	Voltage	DC12/24V(DC10.2 ~ 30V)	
	Current	60mA(TYP.DC24V per common)(base drive current)	

Note1) The maximum voltage drop value at signal ON.

Refer to it for the equipment connected to the output circuit.



### Caution

The protection fuse of the output circuit prevents the failure at the time of the load short circuit and incorrect connection. The load connected of the customer should be careful not to exceed maximum rating current. The internal transistor may be damaged if maximum rating current is exceeded.

#### ■ Installation method

The expansion parallel input/output interface is installed in the controller. Refer to separate "Instruction Manual/Controller setup, basic operation, and maintenance" for details on the installing method.

If it installs in the option SLOT of the controller, the station number will be assigned automatically.

SLOT1: station number 0(0 to 31)

SLOT2: station number 1(32 to 63)



### Caution

If it uses together with parallel input-and-output unit 2A-RZ361/2A-RZ371, please do not overlap with the station number of the parallel input-and-output interface.

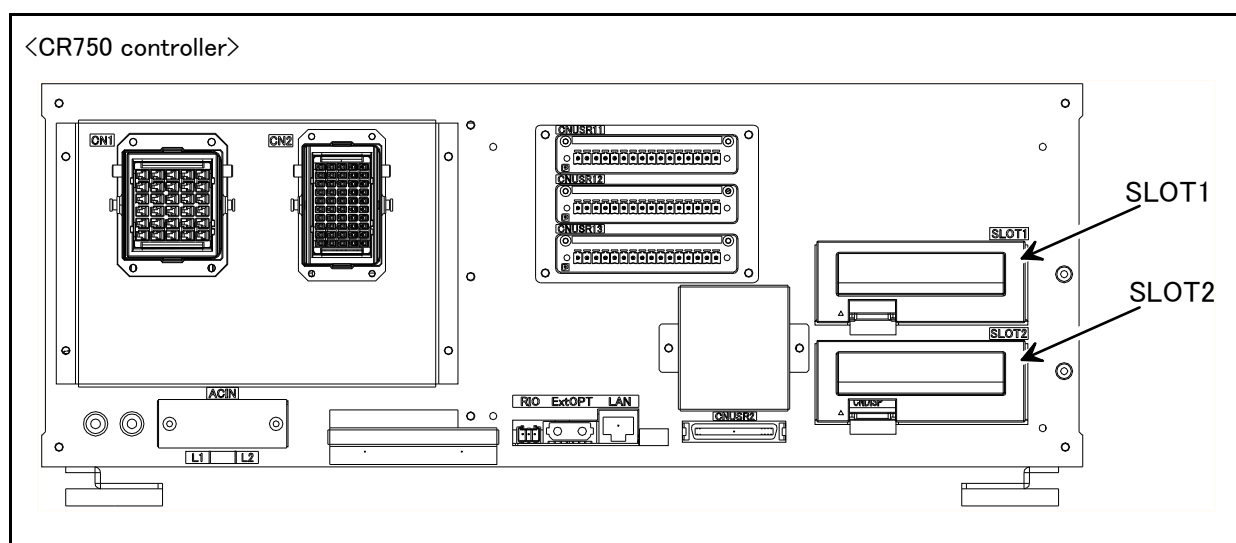

Fig.3-31 : Parallel I/O interface installation position (CR750)

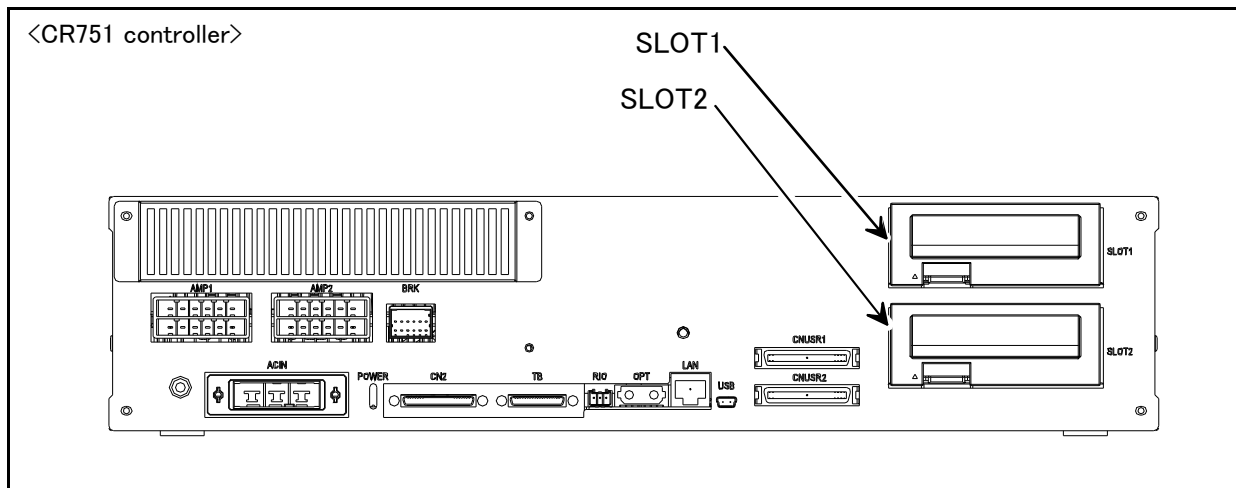

Fig.3-32 : Parallel I/O interface installation position (CR751)

■ Pin layout of connector

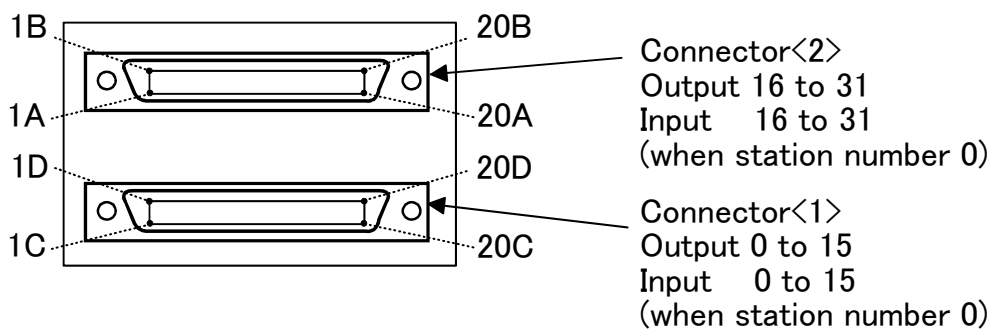

Fig.3-33 : Pin layout of connector

■ Connector pin No. and signal assignment

The station number is fixed by the slot to install and the allocation range of the general-purpose input-and-output signal is fixed.

Table 3-14 : The slot number and the station number

Slot number	Station number	Range of the general-purpose input-and-output signal	
		Connector <1>	Connector <2>
SLOT1	0	Input : 0 to 15 Output : 0 to 15	Input : 16 to 31 Output : 16 to 31
SLOT2	1	Input : 32 to 47 Output : 32 to 47	Input : 48 to 63 Output : 48 to 63

The connector pin number of the parallel input-and-output interface installed in SLOT1 and signal number allocation are shown in Table 3-15 and Table 3-16. If it installs in other slots, please interpret and utilize.

Table 3-15 : Connector&lt;1&gt; pin assignment list and external I/O cable (2D-CBL\*\*) color(SLOT1)

Pin No.	Line color	Function name		Pin No.	Line color	Function name	
		General-purpose	Dedicated/power supply, common			General-purpose	Dedicated/power supply, common
1C	Orange/Red a	General-purpose input 15	24G/12G: For pins 5D-20D	1D	Orange/Black a	General-purpose output 15	+24V/+12V(COM): For pins 5D-20D
2C	Gray/Red a		COM : For pins 5C-20C <sup>Note1)</sup>	2D	Gray/Black a		Reserved
3C	White/Red a		Reserved	3D	White/Black a		Reserved
4C	Yellow/Red a		Reserved	4D	Yellow/Black a		Reserved
5C	Pink/Red a			5D	Pink/Black a		
6C	Orange/Red b	General-purpose input 14		6D	Orange/Black b	General-purpose output 14	
7C	Gray/Red b	General-purpose input 13		7D	Gray/Black b	General-purpose output 13	
8C	White/Red b	General-purpose input 12		8D	White/Black b	General-purpose output 12	
9C	Yellow/Red b	General-purpose input 11		9D	Yellow/Black b	General-purpose output 11	
10C	Pink/Red b	General-purpose input 10		10D	Pink/Black b	General-purpose output 10	
11C	Orange/Red c	General-purpose input 9	Operation rights input signal <sup>Note2)</sup>	11D	Orange/Black c	General-purpose output 9	
12C	Gray/Red c	General-purpose input 8		12D	Gray/Black c	General-purpose output 8	
13C	White/Red c	General-purpose input 7		13D	White/Black c	General-purpose output 7	
14C	Yellow/Red c	General-purpose input 6		14D	Yellow/Black c	General-purpose output 6	
15C	Pink/Red c	General-purpose input 5		15D	Pink/Black c	General-purpose output 5	
16C	Orange/Red d	General-purpose input 4	Servo ON input signal <sup>Note2)</sup>	16D	Orange/Black d	General-purpose output 4	Operation rights output signal <sup>Note2)</sup>
17C	Gray/Red d	General-purpose input 3	Start input <sup>Note2)</sup>	17D	Gray/Black d	General-purpose output 3	
18C	White/Red d	General-purpose input 2	Error reset input signal <sup>Note2)</sup>	18D	White/Black d	General-purpose output 2	
19C	Yellow/Red d	General-purpose input 1	Servo OFF input signal <sup>Note2)</sup>	19D	Yellow/Black d	General-purpose output 1	
20C	Pink/Red d	General-purpose input 0	Stop input <sup>Note3)</sup>	20D	Pink/Black d	General-purpose output 0	

Note1) Sink type: +24V/+12V(COM), Source type: 24G/12G

Note2) The dedicated signal is assigned at shipping. It can change with the parameter.

Note3) The dedicated input signal (STOP) is assigned at shipping. The signal number is fixing.

Table 3-16 : Connector&lt;2&gt; pin assignment list and external I/O cable (2D-CBL\*\*) color(SLOT1)

Pin No.	Line color	Function name		Pin No.	Line color	Function name	
		General-purpose	Dedicated/power supply, common			General-purpose	Dedicated/power supply, common
1A	Orange/Red a	General-purpose input 31	24G/12G: For pins 5B-20B	1B	Orange/Black a	General-purpose output 31	+24V/+12V(COM): For pins 5B-20B
2A	Gray/Red a		COM : For pins 5A-20A <sup>Note1)</sup>	2B	Gray/Black a		Reserved
3A	White/Red a		Reserved	3B	White/Black a		Reserved
4A	Yellow/Red a		Reserved	4B	Yellow/Black a		Reserved
5A	Pink/Red a			5B	Pink/Black a		
6A	Orange/Red b	General-purpose input 30		6B	Orange/Black b	General-purpose output 30	
7A	Gray/Red b	General-purpose input 29		7B	Gray/Black b	General-purpose output 29	
8A	White/Red b	General-purpose input 28		8B	White/Black b	General-purpose output 28	
9A	Yellow/Red b	General-purpose input 27		9B	Yellow/Black b	General-purpose output 27	
10A	Pink/Red b	General-purpose input 26		10B	Pink/Black b	General-purpose output 26	
11A	Orange/Red c	General-purpose input 25		11B	Orange/Black c	General-purpose output 25	
12A	Gray/Red c	General-purpose input 24		12B	Gray/Black c	General-purpose output 24	
13A	White/Red c	General-purpose input 23		13B	White/Black c	General-purpose output 23	
14A	Yellow/Red c	General-purpose input 22		14B	Yellow/Black c	General-purpose output 22	
15A	Pink/Red c	General-purpose input 21		15B	Pink/Black c	General-purpose output 21	
16A	Orange/Red d	General-purpose input 20		16B	Orange/Black d	General-purpose output 20	
17A	Gray/Red d	General-purpose input 19		17B	Gray/Black d	General-purpose output 19	
18A	White/Red d	General-purpose input 18		18B	White/Black d	General-purpose output 18	
19A	Yellow/Red d	General-purpose input 17		19B	Yellow/Black d	General-purpose output 17	
20A	Pink/Red d	General-purpose input 16		20B	Pink/Black d	General-purpose output 16	

Note1) Sink type: +24V/+12V(COM), Source type: 24G/12G

<Reference> The example of connection with our PLC

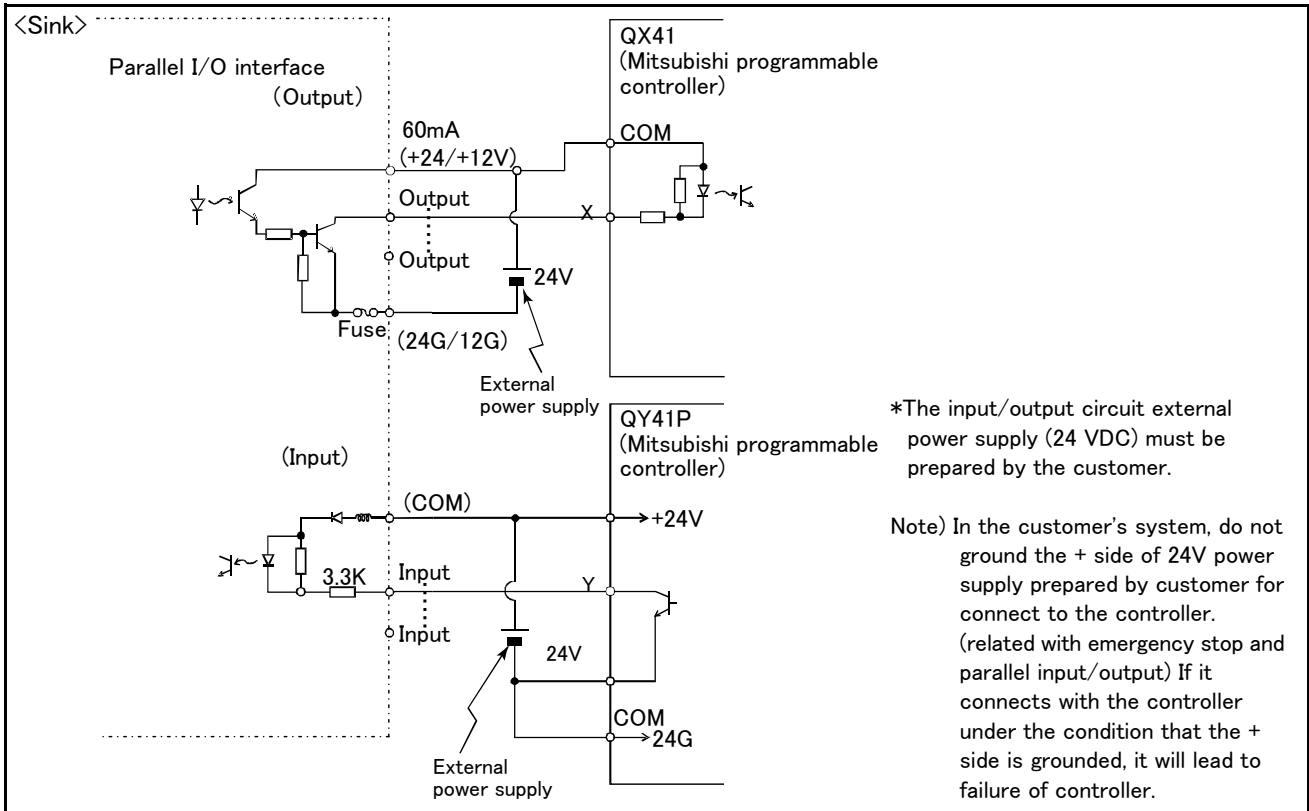

Table 3-17 : Connection with a Mitsubishi PLC (Example of sink type)

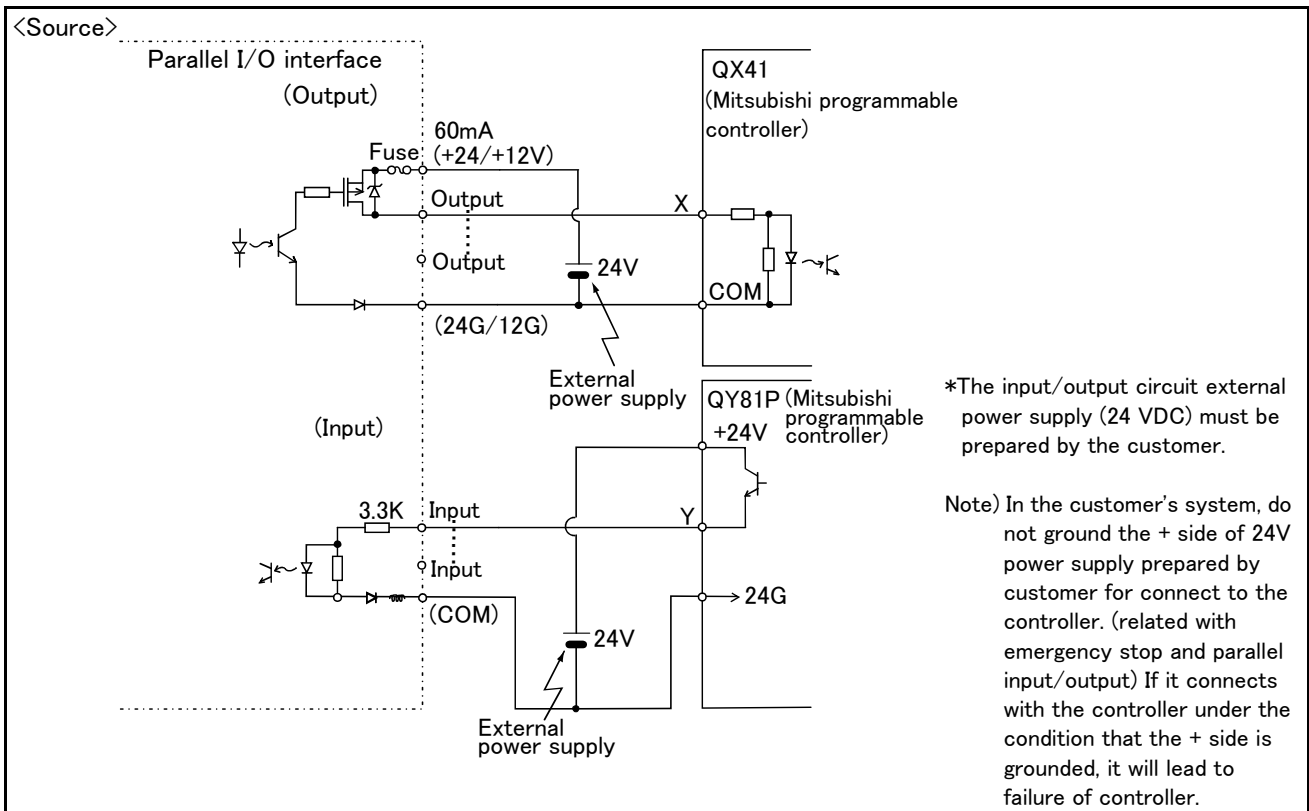

Table 3-18 : Connection with a Mitsubishi PLC (Example of source type)



## (3) External I/O cable

■ Order type : ● 2D-CBL □□ Note) The numbers in the boxes □□ refer to the length. (05: 5m, 15: 15m)

## ■ Outline



This is the dedicated cable used to connect an external peripheral device to the connector on the parallel I/O interface. For parallel I/O unit is another option 2A-CBL.\*\*. One end matches the connector on the parallel input/output unit, and the other end is free. Connect the peripheral device's input/output signal using the free end. One cable correspond to the input 16 points and output 16 points. Two cables are needed to connection of (input 32 points and output 32 points) with built-in standard.

## ■ Configuration

Table 3-19 : Configuration device

Part name	Type	Qty.	Mass (kg) <sup>Note1)</sup>	Remarks
External I/O cable	2D-CBL □□	1 pc.	0.7(5m) 1.84(15m)	5m or 15m

Note1) Mass indicates one set.

## ■ Specifications

Table 3-20 : Specifications

Items	Specifications
Number of cables x cable size	AWG #28 x 20P (40 pairs)
Total length	5m, 15m

## ■ Connector pin numbers and cable colors

Table 3-21 : Connector pin numbers and cable colors

Pin no.	Cable colors	Pin no.	Cable colors	Pin no.	Cable colors	Pin no.	Cable colors
1A/C	Orange/Red a	11A/C	Orange/Red c	1B/D	Orange/Black a	11B/D	Orange/Black c
2A/C	Gray/Red a	12A/C	Gray/Red c	2B/D	Gray/Black a	12B/D	Gray/Black c
3A/C	White/Red a	13A/C	White/Red c	3B/D	White/Black a	13B/D	White/Black c
4A/C	Yellow/Red a	14A/C	Yellow/Red c	4B/D	Yellow/Black a	14B/D	Yellow/Black c
5A/C	Pink/Red a	15A/C	Pink/Red c	5B/D	Pink/Black a	15B/D	Pink/Black c
6A/C	Orange/Red b	16A/C	Orange/Red d	6B/D	Orange/Black b	16B/D	Orange/Black d
7A/C	Gray/Red b	17A/C	Gray/Red d	7B/D	Gray/Black b	17B/D	Gray/Black d
8A/C	White/Red b	18A/C	White/Red d	8B/D	White/Black b	18B/D	White/Black d
9A/C	Yellow/Red b	19A/C	Yellow/Red d	9B/D	Yellow/Black b	19B/D	Yellow/Black d
10A/C	Pink/Red b	20A/C	Pink/Red d	10B/D	Pink/Black b	20B/D	Pink/Black d

Notes) Pin number of connector<1> are 1C, 2C, ...,20C, 1D, 2D, ...,20D, connector<2> are 1A, 2A, ...,20A, 1B, 2B, ...,20B.

■ Connections and outside dimensions

The sheath of each signal cable (40 lines) is color indicated and marked with dots. Refer to the cable color specifications in "Table 3-32: Connector pin numbers and cable colors" when making the connections.

(Eg.) Pin number: color indication

1 : Orange / Red / a

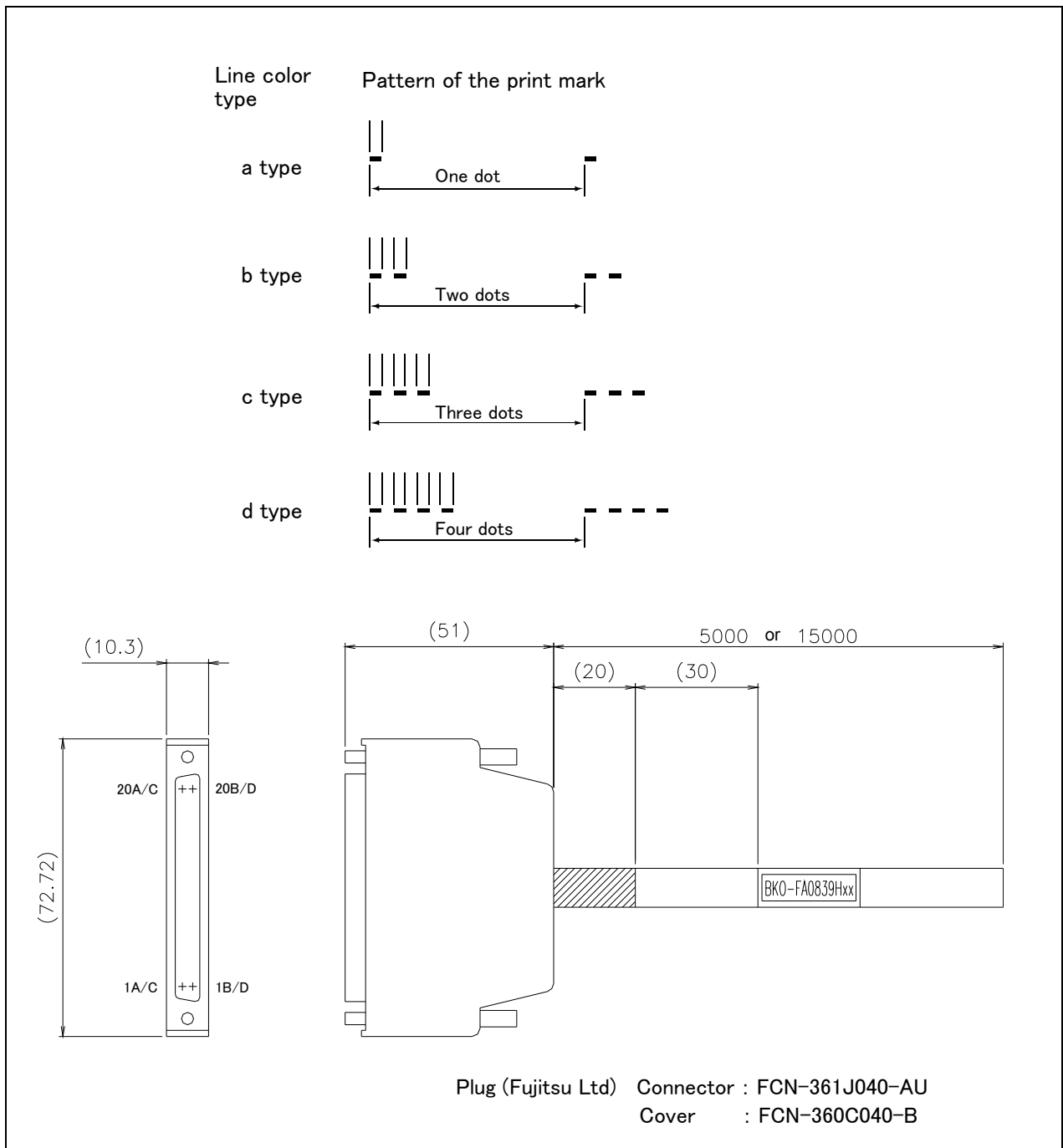
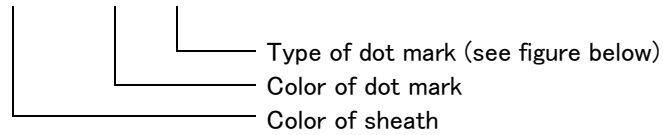

Fig.3-34 : Connections and outside dimensions

## (4) Parallel I/O unit

- Order type: 2A-RZ361(Sink type)  
2A-RZ371(Source type)

- Outline



This is used to expand the external inputs and outputs. One one equal with this unit is built into the control unit among controllers the standard.

- The connection cable is not included. Prepare the optional external input/output cable (2A-CBL05 or 2A-CBL15).
- Use 2A-RZ361 if the external input/output signal logic is of the sink type and 2A-RZ371 for source type signal logic.

Notes) Although the combined use with the parallel I/O interface (2D-TZ368) of another option is also possible, please use the setup of the station number by the different number separately. The station number is automatically fixed by the position of the option slot which installed the parallel I/O interface in 0-1.

- Configuration

Table 3-22 : Configuration device

Part name	Type	Qty.	Mass (kg) <sup>Note1)</sup>	Remarks
Parallel I/O unit	2A-RZ361	Either one pc.	0.7	Input/output 32 points/32 points 2A-RZ361 is the sink type. 2A-RZ371 is the source type.
	2A-RZ371		0.7	
Robot I/O link connection connector	NETcable-1	2 sets	-	Connector with pins. The cable must be prepared and wired by the customer.
Power connection connector	DCcable-2	1 set	-	Connector with pins. The cable must be prepared and wired by the customer.
Terminator	R-TM	1 pc.	-	100Ω (1/4W)

Note1) Mass indicates one set.

- Specifications

- The parallel I/O interface (2D-TZ368) of another option, and the a maximum of eight pieces in all. (One station occupies one unit.)
- The power supply (24V) must be prepared by the customer and connected with the power connection cable (DCcable-2)  
A separate 24V power supply is required for the input/output circuit wiring.

Table 3-23 : Electrical specifications of input circuits

Item	Specification		Internal circuit
Type	DC input		<p>&lt;Sink type&gt;</p> <p>&lt;Source type&gt;</p>
Number of input points	32		
Insulation method	Photo coupler insulation		
Rated input voltage	12VDC	24VDC	
Rated input current	Approx 3mA	Approx 7mA	
Working voltage range	10.2 to 26.4VDC(Ripple factor should be less than 5%.)		
ON voltage/ON current	8VDC or more/ 2mA or more		
OFF voltage/ OFF current	4VDC or less/ 1mA or less		
Input resistance	Approx. 3.3kΩ		
Response time	OFF-ON	10ms or less (24VDC)	
	ON-OFF	10ms or less (24VDC)	
Common method	8 points per common		
External cable connection method	Connector		

Table 3-24 : Electrical specifications for the output circuits

Item		Specification	Internal circuit
Type		Transistor output	<div style="display: flex; flex-direction: column; align-items: center;"> <div style="text-align: center; margin-bottom: 20px;"> <p>&lt;Sink type&gt;</p> </div> <div style="text-align: center;"> <p>&lt;Source type&gt;</p> </div> </div>
No. of output points		32	
Insulation method		Photo-coupler insulation	
Rated load voltage		12VDC/24VDC	
Rated load voltage range		10.2 to 30VDC(peak voltage 30VDC)	
Max. load current		0.1A/point (100%)	
Leakage current at OFF		0.1mA or less	
Max. voltage drop at ON		0.9VDC(TYP.) <sup>Note1)</sup>	
Response time	OFF-ON	2ms or less (hardware response time)	
	ON-OFF	2ms or less (Resistance load) (hardware response time)	
Fuse rating		Fuse 3.2A (one per common) Replacement not possible	
Common method		8 points per common (common terminal: 4 points)	
External wire connection method		Connector	
External power supply	Voltage	12VDC/24VDC(10.2 to 30VDC)	
	Current	60mA (TYP. 24VDC per common) (base drive current)	

Note1) The maximum voltage drop value at signal ON.  
Refer to it for the equipment connected to the output circuit.

**⚠ CAUTION** The output circuit protective fuses prevent failure in case of load short-circuit and improper connections. Please do not connect loads that cause the current to exceed the maximum rated current. If the maximum rated current is exceeded, the internal transistors may be damaged.

**⚠ CAUTION** Inputs the power supply for control (DCcable-2) then inputs the controller's power supply.

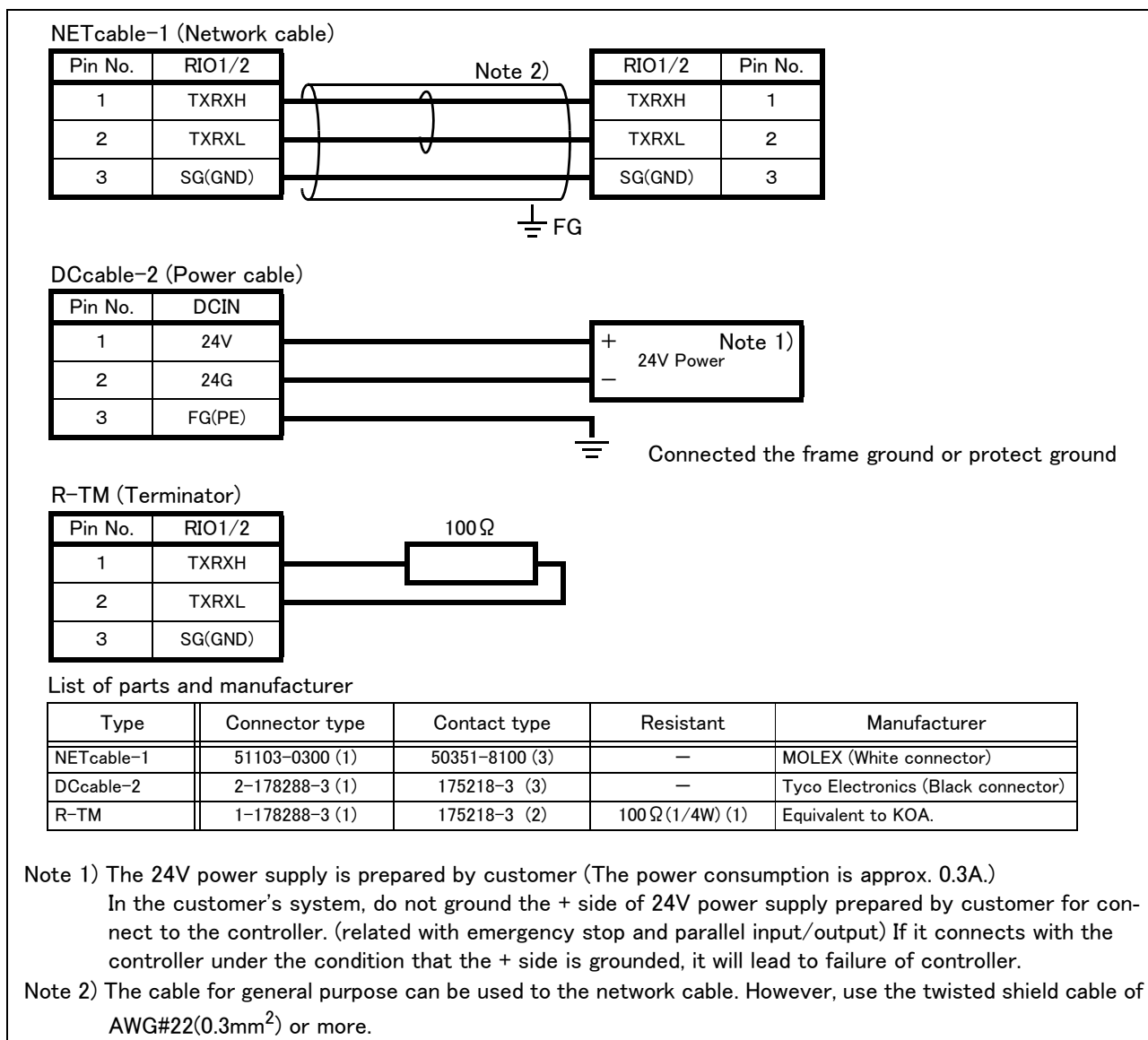

Fig.3-35 : Specifications for the connection cable

■ Installation method

The expansion parallel input/output unit is installed outside of the controller. Connect with the network connection cable (NETcable-1) from the RIO connector in the rear/into of the controller.(Terminator is connected at the time of shipment)

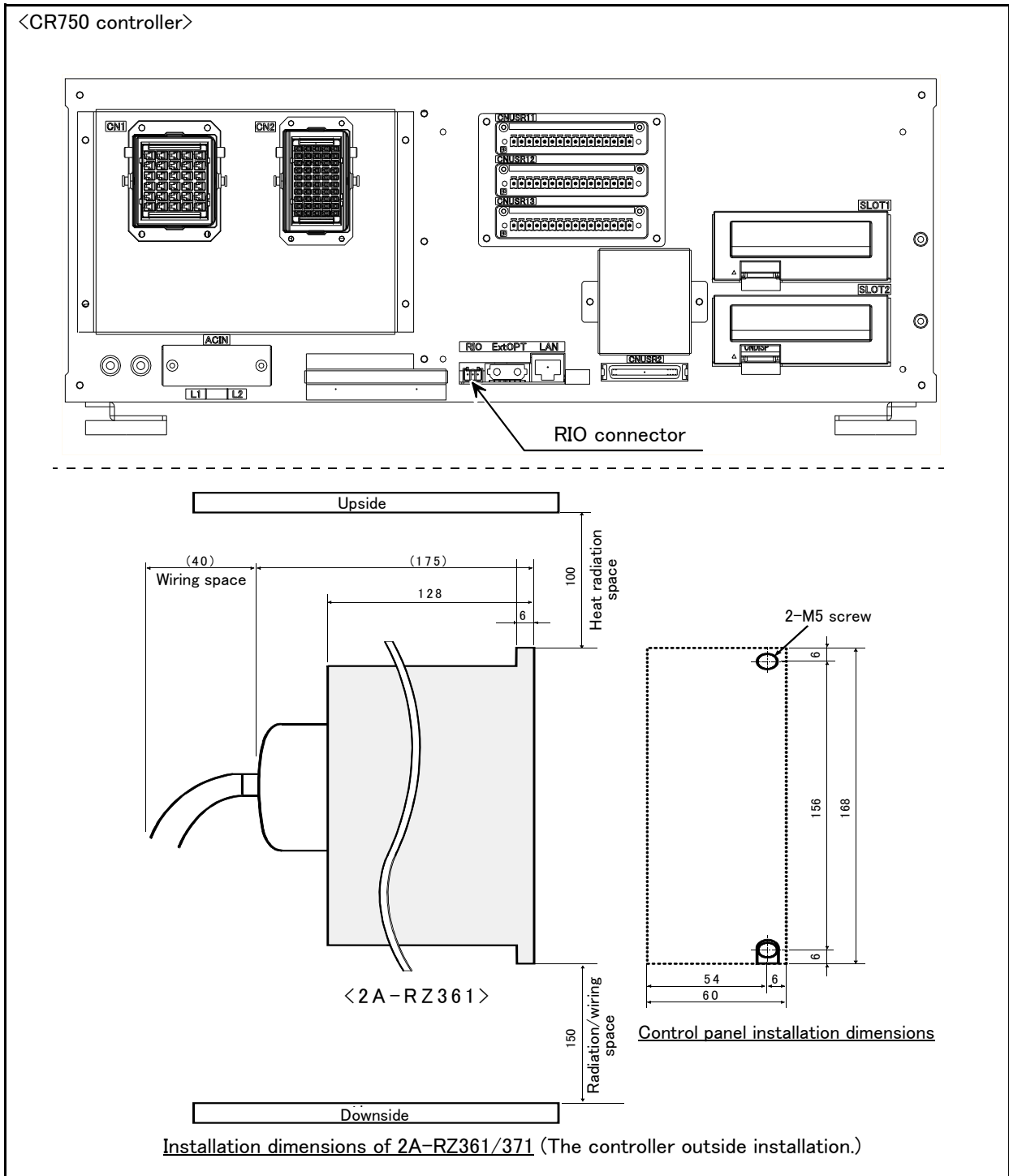

Fig.3-36 : Installing the parallel I/O unit (CR750)

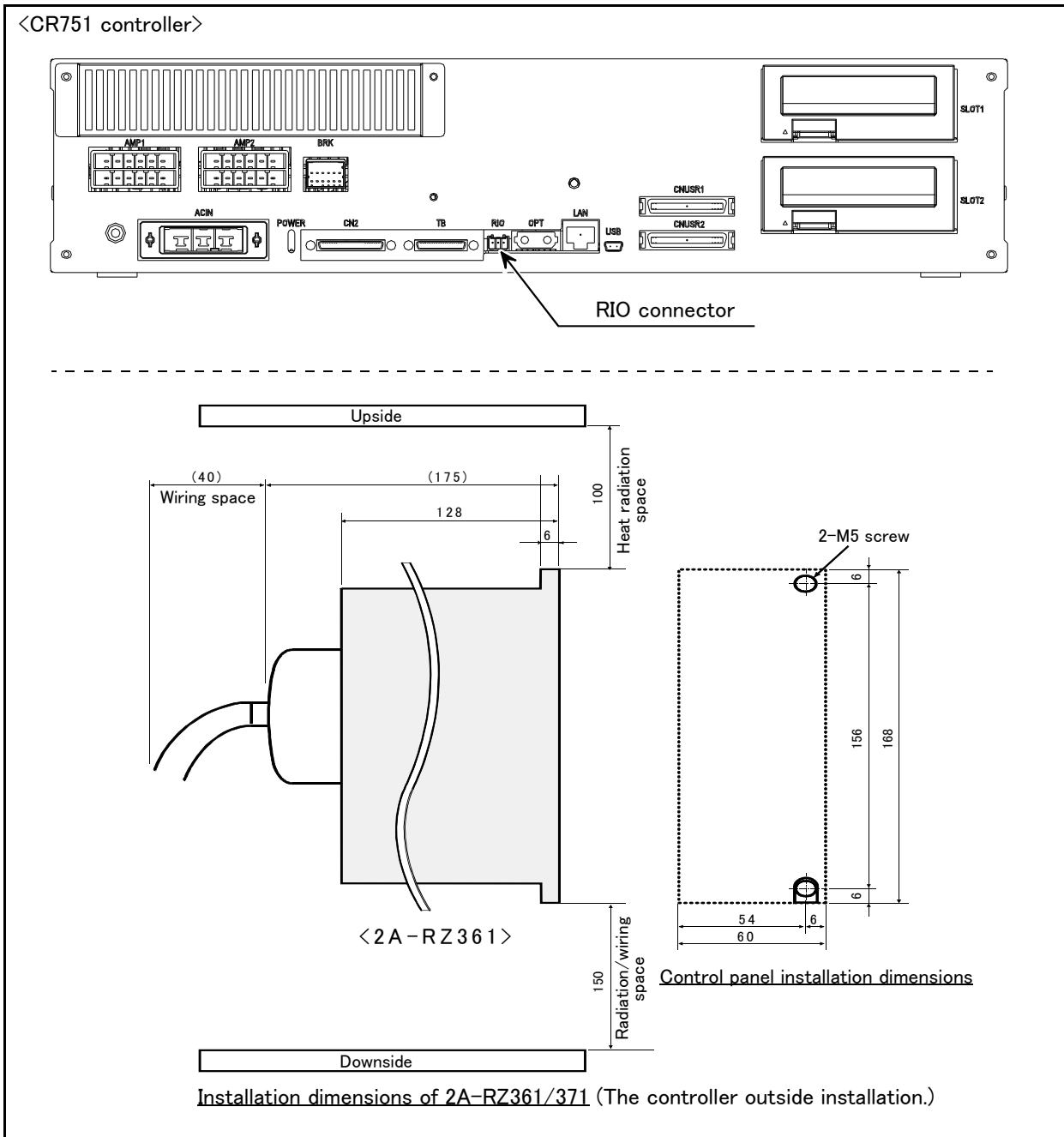

Fig.3-37 : Installing the parallel I/O unit (CR751)

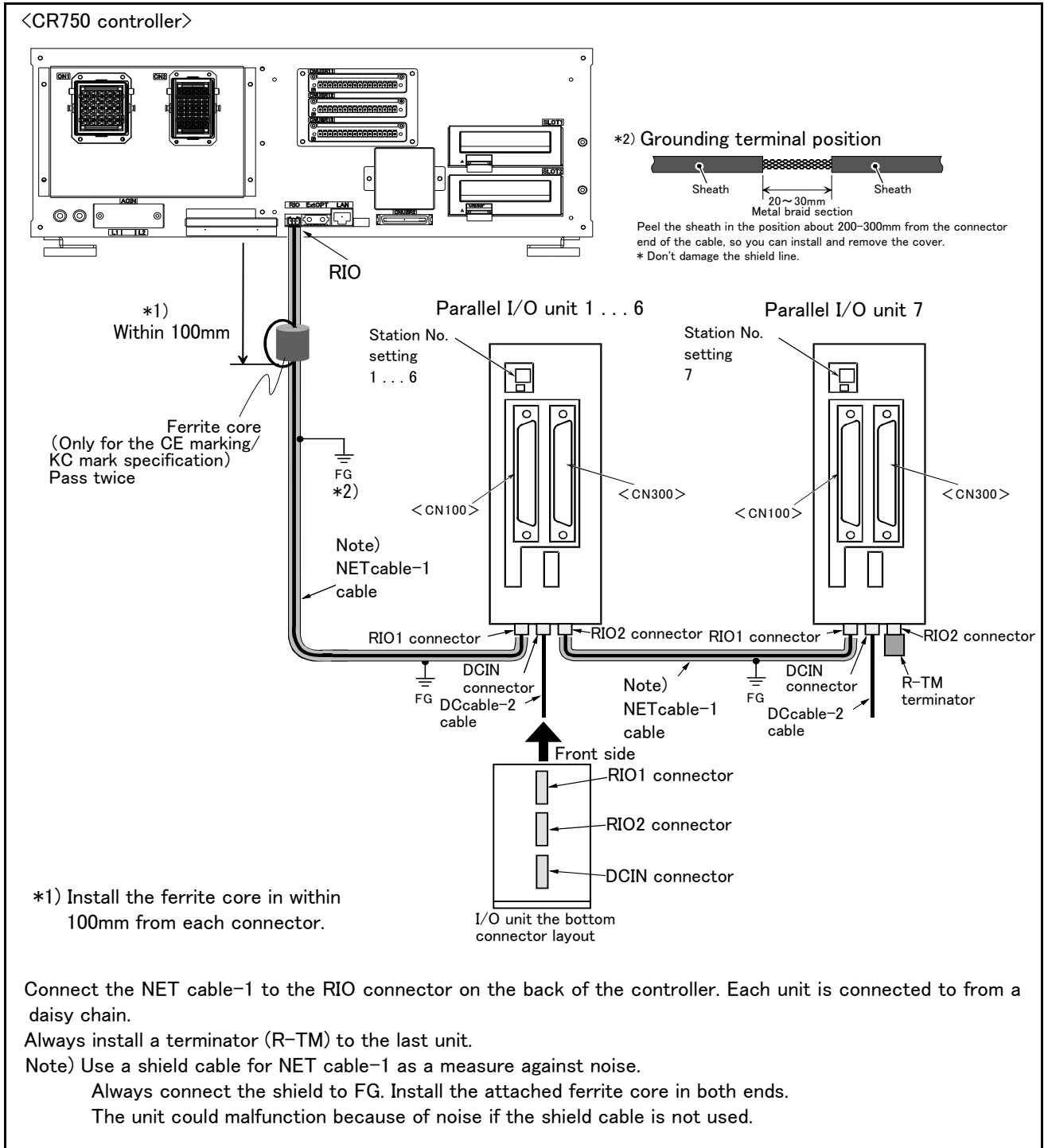

Fig.3-38 : Connection method of expansion parallel I/O unit (CR750)



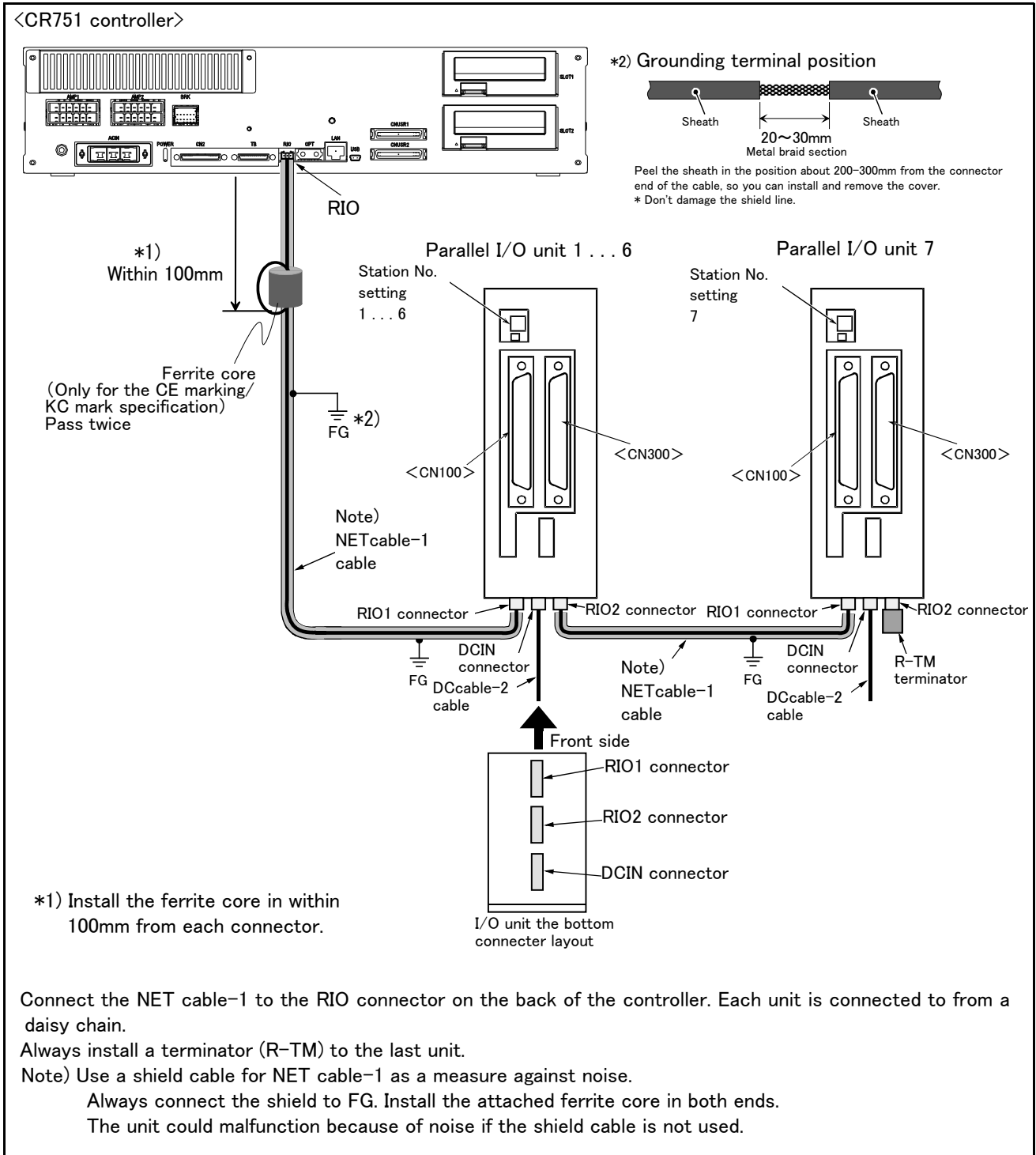
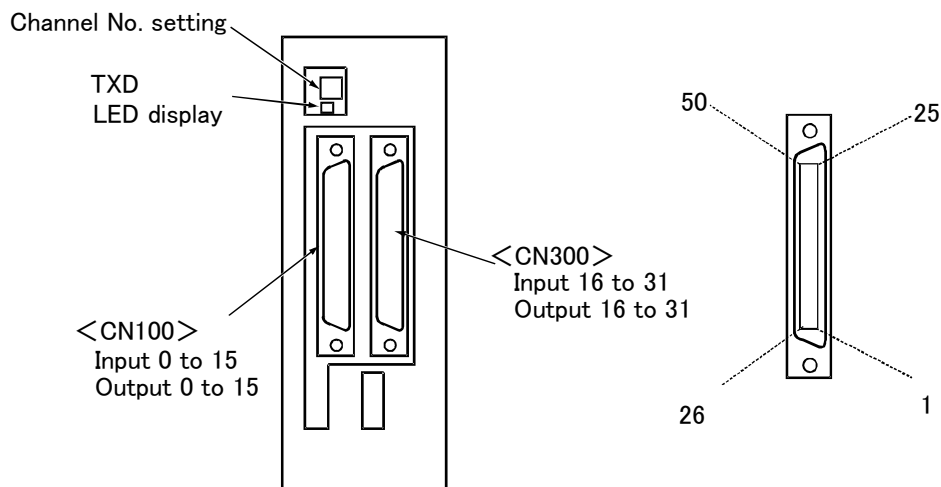

Fig.3-39 : Connection method of expansion parallel I/O unit (CR751)

■ Pin arrangement of the connector



\*2A-RZ361/2 A-RZ371 are 32/32 input-and-output units. (One-station occupancy)

Fig.3-40 : Pin arrangement of the parallel I/O unit

■ Assignment of pin number and signal

The assignment range of the general-purpose input-and-output signal is fixed by the setup of the station number.

Table 3-25 : Assignment of pin number and signal

Unit Number	Station number	CN100	CN300
1st set	0	Input : 0 to 15 Output : 0 to 15	Input : 16 to 31 Output : 16 to 31
2nd set	1	Input : 32 to 47 Output : 32 to 47	Input : 48 to 63 Output : 48 to 63
3rd set	2	Input : 64 to 79 Output : 64 to 79	Input : 80 to 95 Output : 80 to 95
4th set	3	Input : 96 to 111 Output : 96 to 111	Input : 112 to 127 Output : 112 to 127
5th set	4	Input : 128 to 143 Output : 128 to 143	Input : 144 to 159 Output : 144 to 159
6th set	5	Input : 160 to 175 Output : 160 to 175	Input : 176 to 191 Output : 176 to 191
7th set	6	Input : 192 to 207 Output : 192 to 207	Input : 208 to 223 Output : 208 to 223
8th set	7	Input : 224 to 239 Output : 224 to 239	Input : 240 to 255 Output : 240 to 255

The connector pin number of the parallel I/O unit of the station number 0 and signal number assignment are shown in Table 3-26 and Table 3-27. If it is set as other station number, please interpret and utilize.

■ Parallel I/O interface (First expansion unit)

Table 3-26 : Connector CN100pin No. and signal assignment list (2A-CBL □□)

Pin No.	Line color	Function name		Pin No.	Line color	Function name	
		General-purpose	Dedicated/power supply, common			General-purpose	Dedicated/power supply, common
1	Orange/Red A		FG	26	Orange/Blue A		FG
2	Gray/Red A		0V:For pins 4-7, 10-13	27	Gray/Blue A		0V:For pins 29-32, 35-38
3	White/Red A		12V/24V:For pins 4-7	28	White/Blue A		12V/24V:For pins 29-32
4	Yellow/Red A	General-purpose output 0	Operating output <sup>Note1)</sup>	29	Yellow/Blue A	General-purpose output 4	
5	Pink/Red A	General-purpose output 1	In servo ON output signal <sup>Note1)</sup>	30	Pink/Blue A	General-purpose output 5	
6	Orange/Red B	General-purpose output 2	Error occurring output signal <sup>Note1)</sup>	31	Orange/Blue B	General-purpose output 6	
7	Gray/Red B	General-purpose output 3	Operation rights output signal <sup>Note1)</sup>	32	Gray/Blue B	General-purpose output 7	
8	White/Red B		0V:For pins 4-7, 10-13	33	White/Blue B		0V:For pins 29-32, 35-38
9	Yellow/Red B		12V/24V:For pins 10-13	34	Yellow/Blue B		12V/24V:For pins 35-38
10	Pink/Red B	General-purpose output 8		35	Pink/Blue B	General-purpose output 12	
11	Orange/Red C	General-purpose output 9		36	Orange/Blue C	General-purpose output 13	
12	Gray/Red C	General-purpose output 10		37	Gray/Blue C	General-purpose output 14	
13	White/Red C	General-purpose output 11		38	White/Blue C	General-purpose output 15	
14	Yellow/Red C		COM0:For pins 15-22 <sup>Note2)</sup>	39	Yellow/Blue C		COM1:For pins 40-47 <sup>Note2)</sup>
15	Pink/Red C	General-purpose input 0	Stop input <sup>Note3)</sup>	40	Pink/Blue C	General-purpose input 8	
16	Orange/Red D	General-purpose input 1	Servo OFF input signal <sup>Note1)</sup>	41	Orange/Blue D	General-purpose input 9	
17	Gray/Red D	General-purpose input 2	Error reset input signal <sup>Note1)</sup>	42	Gray/Blue D	General-purpose input 10	
18	White/Red D	General-purpose input 3	Start input <sup>Note1)</sup>	43	White/Blue D	General-purpose input 11	
19	Yellow/Red D	General-purpose input 4	Servo ON input signal <sup>Note1)</sup>	44	Yellow/Blue D	General-purpose input 12	
20	Pink/Red D	General-purpose input 5	Operation rights input signal <sup>Note1)</sup>	45	Pink/Blue D	General-purpose input 13	
21	Orange/Red E	General-purpose input 6		46	Orange/Blue E	General-purpose input 14	
22	Gray/Red E	General-purpose input 7		47	Gray/Blue E	General-purpose input 15	
23	White/Red E		Reserved	48	White/Blue E		Reserved
24	Yellow/Red E		Reserved	49	Yellow/Blue E		Reserved
25	Pink/Red E		Reserved	50	Pink/Blue E		Reserved

Note1) The dedicated signal is assigned at shipping. It can change with the parameter.

Note2) Sink type:12V/24V(COM),Source type:0V(COM)

Note3) The dedicated input signal (STOP) is assigned at shipping. The signal number is fixing.

Table 3-27 : Connector CN300pin No. and signal assignment list (2A-CBL □□ )

Pin No.	Line color	Function name		Pin No.	Line color	Function name	
		General-purpose	Dedicated/power supply, common			General-purpose	Dedicated/power supply, common
1	Orange/Red A		FG	26	Orange/Blue A		FG
2	Gray/Red A		0V:For pins 4-7, 10-13	27	Gray/Blue A		0V:For pins 29-32, 35-38
3	White/Red A		12V/24V:For pins 4-7	28	White/Blue A		12V/24V:For pins 29-32
4	Yellow/Red A	General-purpose output 16		29	Yellow/Blue A	General-purpose output 20	
5	Pink/Red A	General-purpose output 17		30	Pink/Blue A	General-purpose output 21	
6	Orange/Red B	General-purpose output 18		31	Orange/Blue B	General-purpose output 22	
7	Gray/Red B	General-purpose output 19		32	Gray/Blue B	General-purpose output 23	
8	White/Red B		0V:For pins 4-7, 10-13	33	White/Blue B		0V:For pins 29-32, 35-38
9	Yellow/Red B		12V/24V:For pins 10-13	34	Yellow/Blue B		12V/24V:For pins 35-38
10	Pink/Red B	General-purpose output 24		35	Pink/Blue B	General-purpose output 28	
11	Orange/Red C	General-purpose output 25		36	Orange/Blue C	General-purpose output 29	
12	Gray/Red C	General-purpose output 26		37	Gray/Blue C	General-purpose output 30	
13	White/Red C	General-purpose output 27		38	White/Blue C	General-purpose output 31	
14	Yellow/Red C		COM0:For pins 15-22 <sup>Note1)</sup>	39	Yellow/Blue C		COM1:For pins 40-47 <sup>Note1)</sup>
15	Pink/Red C	General-purpose input 16		40	Pink/Blue C	General-purpose input 24	
16	Orange/Red D	General-purpose input 17		41	Orange/Blue D	General-purpose input 25	
17	Gray/Red D	General-purpose input 18		42	Gray/Blue D	General-purpose input 26	
18	White/Red D	General-purpose input 19		43	White/Blue D	General-purpose input 27	
19	Yellow/Red D	General-purpose input 20		44	Yellow/Blue D	General-purpose input 28	
20	Pink/Red D	General-purpose input 21		45	Pink/Blue D	General-purpose input 29	
21	Orange/Red E	General-purpose input 22		46	Orange/Blue E	General-purpose input 30	
22	Gray/Red E	General-purpose input 23		47	Gray/Blue E	General-purpose input 31	
23	White/Red E		Reserved	48	White/Blue E		Reserved
24	Yellow/Red E		Reserved	49	Yellow/Blue E		Reserved
25	Pink/Red E		Reserved	50	Pink/Blue E		Reserved

Note1) Sink type:12V/24V(COM),Source type:0V(COM)

<Reference> The example of connection with our PLC

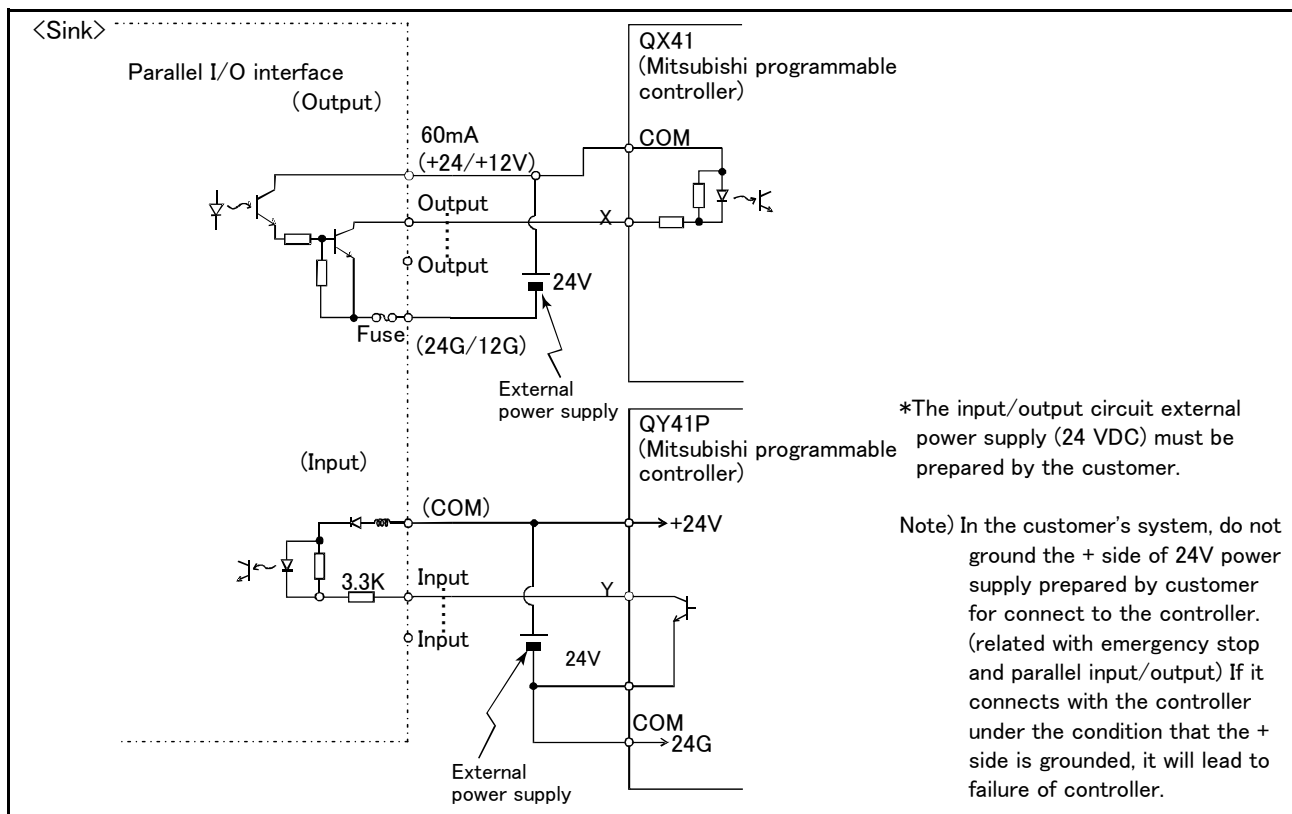

Table 3-28 : Connection with a Mitsubishi PLC (Example of sink type)

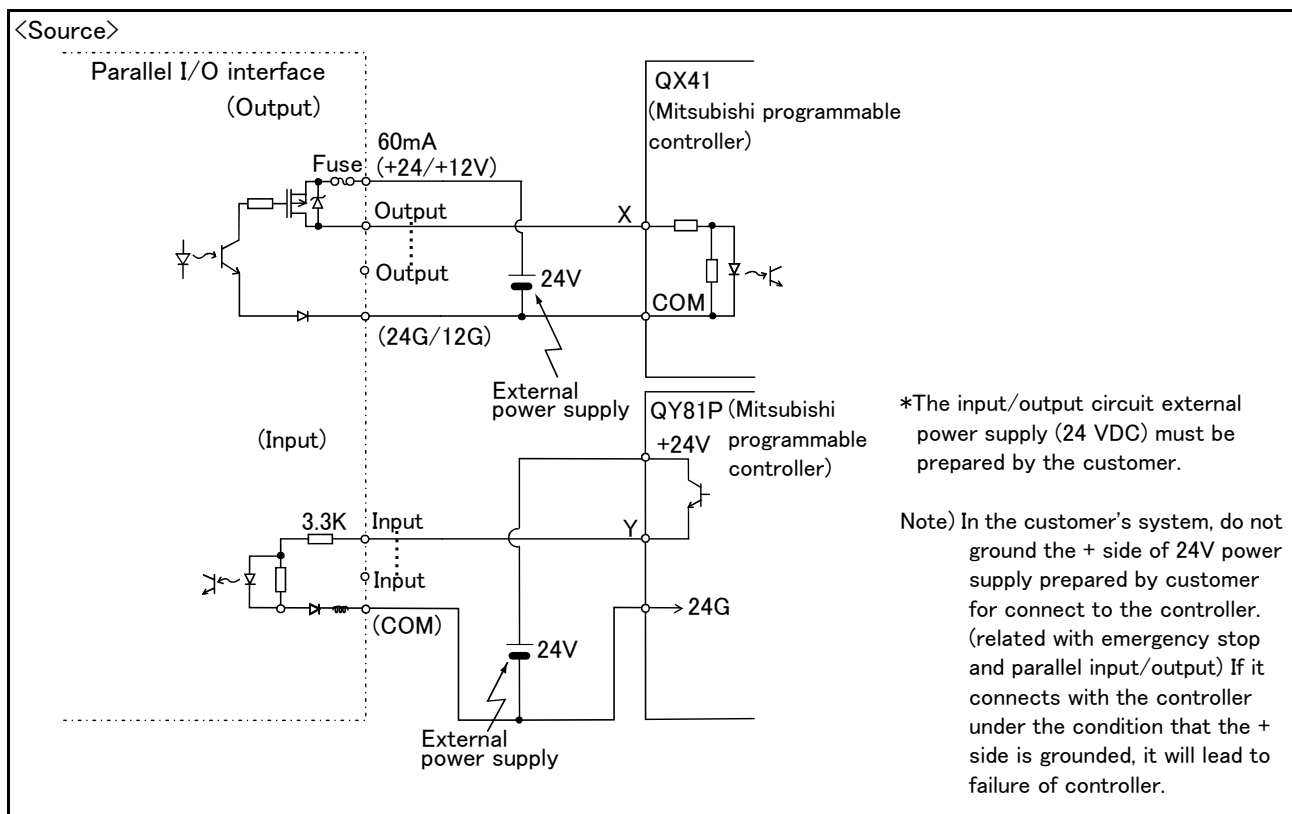

Table 3-29 : Connection with a Mitsubishi PLC (Example of source type)

(5) External I/O cable

■ Order type: 2A-CBL □□ Note) The numbers in the boxes □□ refer to the length. (05: 5m、15: 15m)

■ Outline



This is the dedicated cable used to connect an external peripheral device to the connector on the parallel input/output unit.  
 One end matches the connector on the parallel input/output unit, and the other end is free. Connect the peripheral device's input/output signal using the free end.  
 One cable correspond to the input 16 points and output 16 points.  
 Two cables are needed to connection of (input 32 points and output 32 points) with built-in standard.

■ Configuration

Table 3-30 : Configuration device

Part name	Type	Qty.	Mass(kg) <sup>Note1)</sup>	Remarks
External I/O cable	2A-CBL □□	1pc.	0.7(5m) 1.84(15m)	5m or 15m

Note1) Mass indicates one set.

■ Specifications

Table 3-31 : Specifications

Items	Specifications
Number of cables x cable size	50 pairs x AWG #28
Total length	5m or 15m

■ Connector pin numbers and cable colors

Table 3-32 : Connector pin numbers and cable colors

Pin no.	Cable colors	Pin no.	Cable colors	Pin no.	Cable colors	Pin no.	Cable colors	Pin no.	Cable colors
1	Orange/Red A	11	Orange/Red C	21	Orange/Red E	31	Orange/Blue B	41	Orange/Blue D
2	Gray/Red A	12	Gray/Red C	22	Gray/Red E	32	Gray/Blue B	42	Gray/Blue D
3	White/Red A	13	White/Red C	23	White/Red E	33	White/Blue B	43	White/Blue D
4	Yellow/Red A	14	Yellow/Red C	24	Yellow/Red E	34	Yellow/Blue B	44	Yellow/Blue D
5	Pink/Red A	15	Pink/Red C	25	Pink/Red E	35	Pink/Blue B	45	Pink/Blue D
6	Orange/Red B	16	Orange/Red D	26	Orange/Blue A	36	Orange/Blue C	46	Orange/Blue E
7	Gray/Red B	17	Gray/Red D	27	Gray/Blue A	37	Gray/Blue C	47	Gray/Blue E
8	White/Red B	18	White/Red D	28	White/Blue A	38	White/Blue C	48	White/Blue E
9	Yellow/Red B	19	Yellow/Red D	29	Yellow/Blue A	39	Yellow/Blue C	49	Yellow/Blue E
10	Pink/Red B	20	Pink/Red D	30	Pink/Blue A	40	Pink/Blue C	50	Pink/Blue E

■ Connections and outside dimensions

The sheath of each signal cable (50 lines) is color indicated and marked with dots. Refer to the cable color specifications in "Table 3-32: Connector pin numbers and cable colors" when making the connections.

(Eg.) Pin number: color indication

1 : Orange / Red / A

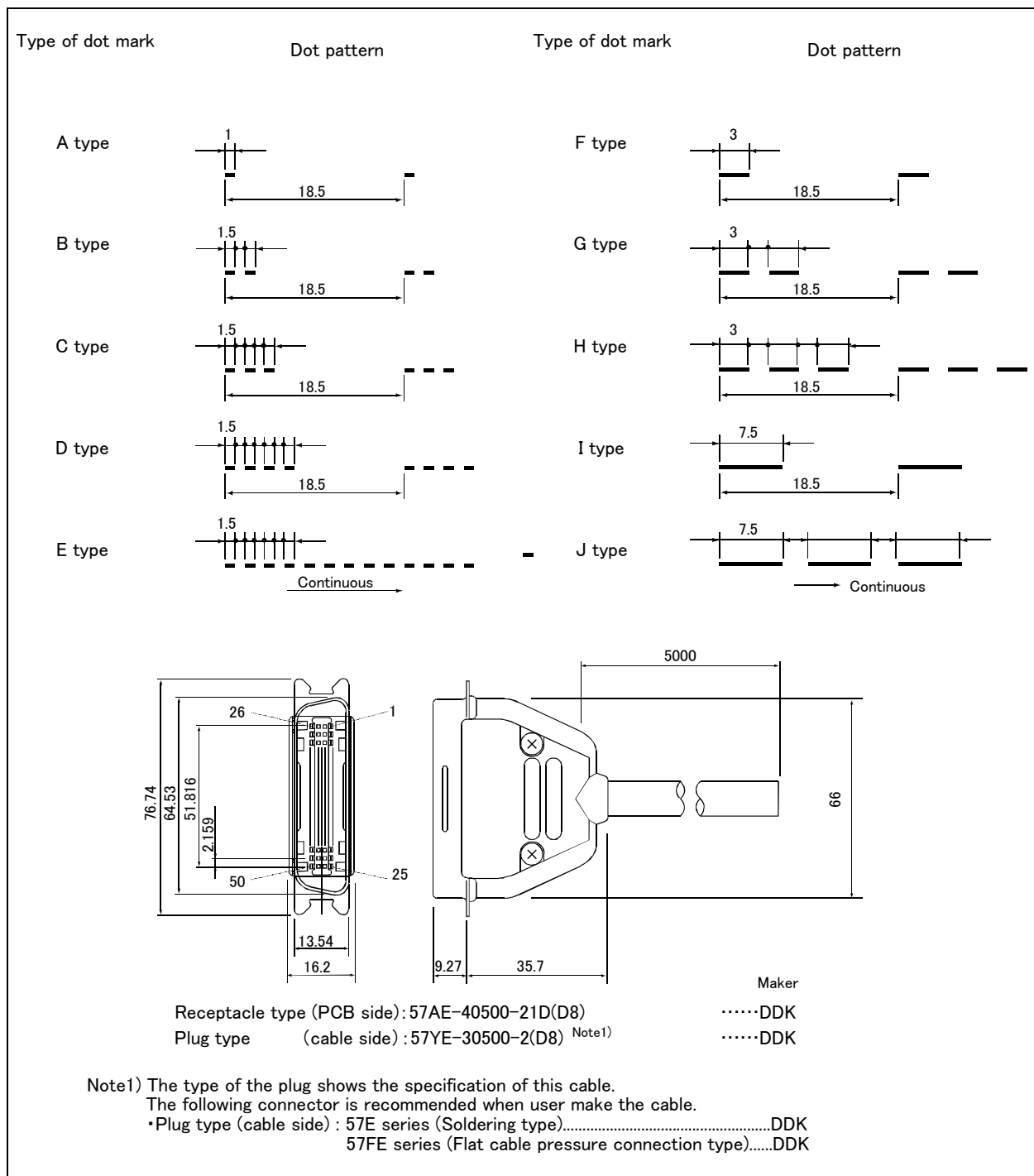
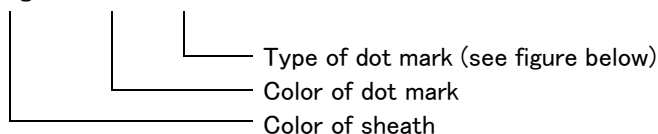

Fig.3-41 : Connections and outside dimensions

(6) CC-Link interface

■ Order type: ● 2D-TZ576

■ Outline



The CC-Link interface is the option interface to not only add bit data to the robot controller, but also to add CC-Link field network function that allows cyclic transmission of word data.

■ Configuration

Table 3-33 : Configuration device

Part name	Type	Qty.	Mass(kg) <sup>Note1)</sup>	Remarks
CC-Link interface	TZ576	1	0.6	
Manual	BFP-A8701	1	-	
Ferrite core	E04SR301334	2	-	Be sure to install this for noise countermeasure.
Cable clamp	AL4	2	-	
	AL5	2	-	

Note1) Mass indicates one set.

Table 3-34 : Procured by the customer

Part name	Type	Qty.	Remarks
Master station	QJ61BT11(Q series)	1	FX series products are not supported.
	QJ61BT11N(Q series)		
	AJ61QBT11(QnA series)		
	A1SJ61QBT11(QnAS series)		
	AJ61BT11(A series)		
	A1SJ61BT11(AnS series)		
	A80BD-J61BT11(personal computer board)		
Communication cable	-	1	Shielded 3-core twisted cable This cable may be manufactured by the customer.
Terminal resistor	-	1	110Ω or 130Ω is recommended.

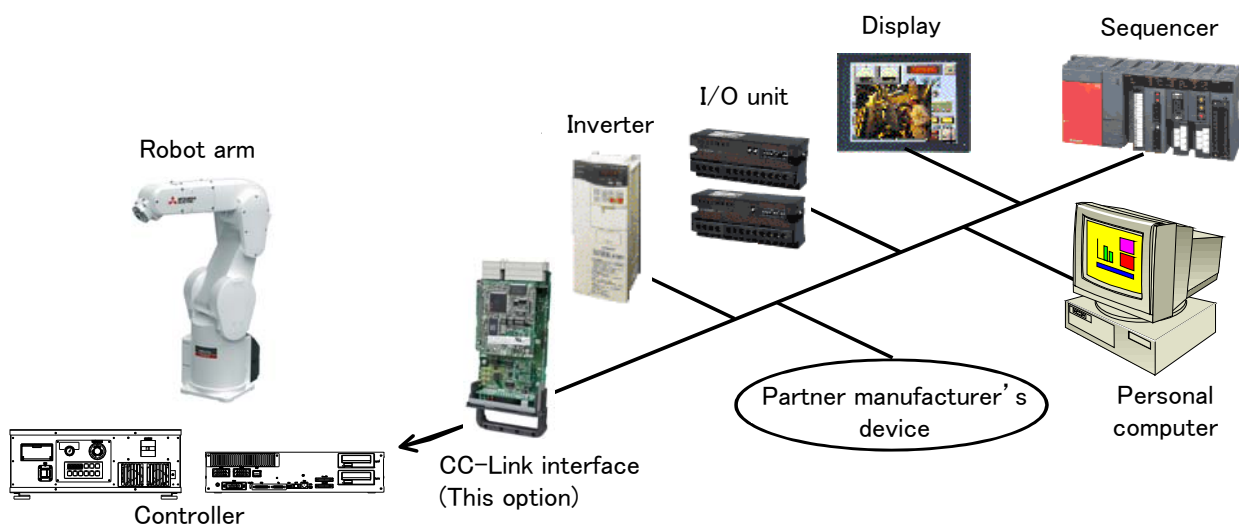

Fig.3-42 : Example of CC-Link Product Configuration



## ■ Specifications

Table 3-35 : Specifications

Item		Specifications				Remarks	
Communication function		Bit data and word data can be transmitted.				Word data are used by the registers.	
Station type		Intelligent device station <sup>Note1)</sup>					
Support station		Local station				No master station function	
The version corresponding to CC-Link		Ver.2				The extended cyclic setup is possible.	
Mountable option slot		Slot 1, 2					
Number of mountable CC-Link interface cards		1				Multiple CC-Link interface cards cannot be inserted.	
Number of stations		1 to 64 stations				When four stations are occupied, continuous station numbers are used. The station numbers are set by a DIP switch.	
Transmission speed		10M/5M/2.5M/625K/156K bps				This is set by the rotary SW.	
Station number		1 to 64				When two or more stations are occupied, continuous station numbers are used.	
Number of occupied stations		1/2/3/4					
Extended cyclic setup		1/2/4/8					
Maximum link point		Remote I/O (RX, RY).	Each 896 points				The two last cannot be used.
		Remote register (RW <sub>r</sub> , RW <sub>w</sub> )	Each 128 register				16 bits/register
Extended cyclic setup		–	1 fold setup	2 fold setup	3 fold setup	4 fold setup	
Link point per set	When one station is occupied	Remote I/O (RX, RY).	32 point	32 point	64 point	128 point	
		Remote register ( RW <sub>w</sub> )	4 word	8 word	16 word	32 word	
		Remote register (RW <sub>r</sub> )	4 word	8 word	16 word	32 word	
	When two stations is occupied	Remote I/O (RX, RY).	64 point	96 point	192 point	384 point	
		Remote register ( RW <sub>w</sub> )	8 word	16 word	32 word	64 word	
		Remote register (RW <sub>r</sub> )	8 word	16 word	32 word	64 word	
	When three stations is occupied	Remote I/O (RX, RY).	96 point	160 point	320 point	640 point	
		Remote register ( RW <sub>w</sub> )	12 word	24 word	48 word	96 word	
		Remote register (RW <sub>r</sub> )	12 word	24 word	48 word	96 word	
	When four stations is occupied	Remote I/O (RX, RY).	128 point	224 point	448 point	896 point	
		Remote register ( RW <sub>w</sub> )	16 word	32 word	64 word	128 word	
		Remote register (RW <sub>r</sub> )	16 word	32 word	64 word	128 word	
Number of the maximum occupancy station		4 stations					
The I/O first number of the robot controller.		No. 6000 – The number corresponding to the station number by the setup of the parameter "CCFIX."					

Note1) The CC-Link interface supports neither the transient transmission function nor the FX series.

■ Functions

(1) Communication function

- The number of usable points is 896 points maximum for bit control and 128 points maximum for word control.

(2) Easy setup

- The CC-Link interface card can be set by a rotary switch or DIP switch.
- No separate space is required to mount the CC-Link interface card as it is embedded in the robot controller (can only be mounted into slot 2).
- Easy wiring since only four terminals need to be connected.
- Dedicated commands have been added to MELFA-BASIC V (robot programming language); thus, no complex interface programming is required.

(3) High-speed response

- The link scan time when connecting 64 stations is approximately 7.2 ms, achieving superior high-speed response performance.
- A transmission speed can be selected from 10M, 5M, 2.5M, 625K and 156K bps according to the transmission distance.

## (7) RT ToolBox2/RT ToolBox2 mini

- Order type : ● RT ToolBox2  
                   \*For windows CD-ROM : 3D-11C-WINE  
 ● RT ToolBox2 mini  
                   \*For windows CD-ROM : 3D-12C-WINE

## ■ Outline



This is handy software that fully uses the personal computer functions. It can be used in various stages from the robot specifications study (tact study, etc.) to the design support (creation and editing of programs), start up support (execution, control and debugging of program), and maintenance.

The "personal computer support software" which supports these function fully, and the "personal computer support software mini" which does not have the simulation function are available.

## ■ Configuration

Table 3-36 : Product configuration

Part name	Type	Medium	Mass (kg) <sup>Note1)</sup>	Remarks
RT ToolBox2	3D-11C-WINE	CD-ROM	0.2	
RT ToolBox2 mini	3D-12C-WINE	CD-ROM	0.2	

Note1) Mass indicates one set.

## ■ Features

- (1) Simple operation with guidance method and menu method  
 The Windows standard is used for windows operation, so the controller initialization and startup operations can be carried out easily by following the instructions given on the screen. Even a beginner can easily carry out the series of operations from program creation to execution.
- (2) Increased work efficiency with ample support functions  
 The work efficiency is greatly improved with the multi-window method that carries out multiple steps and displays in parallel. The renumbering function, and copy, search, syntax check and step execution are especially sufficient, and are extremely useful when editing or debugging the program.  
 With the simulation function support, the program can be debugged and the tact checked before starting the machine at the site. This allows the on-site startup work efficiently to be greatly improved.
- (3) The maintenance forecast function increases the efficiency of maintenance work. Analyze the load condition while the robot is actually operating. Based on this analysis, calculate the time for maintenance, such as lubrication and belt replacement. By utilizing this information, the line stop time as well as the maintenance costs can be reduced.
- (4) The position recovery support function increases the recovery efficiency in the event of origin position displacement. This function compensates the origin settings and position data by just reproducing several previous teaching points when hand and/or arm displacement occurs, when replacing the motor and the belts, or when reloading the robot. This function can reduce the time required for recovery.

■ Functions

Table 3-37 : Functions

Function		Functional existence <sup>Note1)</sup>		Details
Compatible model		○	○	Personal computer running Windows XP, Windows Vista, Windows 7, Windows 8, or Windows 8.1. <sup>Note2)</sup>
Program editing functions	Editing functions	○	○	<ul style="list-style-type: none"> <li>▪ MELFA BASIC V language compatible</li> <li>▪ Multiple editing screen simultaneously display</li> <li>▪ Command input, comment writing</li> <li>▪ Position data editing</li> <li>▪ File operation (writing to controller, floppy disk, personal computer)</li> <li>▪ Search and replace function (using characters, line Nos., labels)</li> <li>▪ Copy, cut, paste, insert (per character, line), undo (per command statement, position conversion)</li> <li>▪ Line No. automatic generation, renumbering</li> <li>▪ Batch syntax check</li> <li>▪ Command template</li> <li>▪ Position conversion batch editing</li> <li>▪ Position variable template</li> <li>▪ Print, print preview</li> </ul>
	Control functions	○	○	<ul style="list-style-type: none"> <li>▪ Program file control (list, copy, movement, delete, content comparison, name change, protect)</li> </ul>
	Debugging functions	○	○	<ul style="list-style-type: none"> <li>▪ Direct editing of program in controller</li> <li>▪ Confirmation of robot program operation (step execution, direct execution)</li> </ul>
Simulation function		○	×	<ul style="list-style-type: none"> <li>▪ Off-line simulation of robot program operation using CG (computer graphics)</li> <li>▪ Tact time calculation</li> </ul>
Monitor functions		○	○	<ul style="list-style-type: none"> <li>▪ Robot operation monitor (robot operation state, stop signal, error monitor, program monitor (execution program, variables), general-purpose input/output signals (forced output possible), dedicated input/output signals, operation confirmation (operation range, current position, hand, etc.)</li> <li>▪ Operation monitor (working time statistics, production information, robot version)</li> <li>▪ Servo monitor (load)</li> </ul>
Maintenance function		○	○	<ul style="list-style-type: none"> <li>▪ Parameter setting</li> <li>▪ Batch, divided backup</li> </ul>

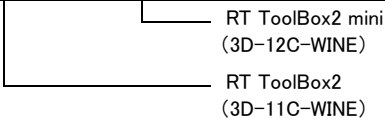

Note1) The functions included with the RT ToolBox2 and the RT ToolBox2 mini are shown below.

○ : Function provided    × : Function not provided

Note2) Recommend corresponding to CE Marking, an FCC standard, and a VCCI standard.

## (8) Instruction Manual (bookbinding)

■ Order type: ● 5F-FA01-PE01 .....RH-3FH-D series

■ Outline

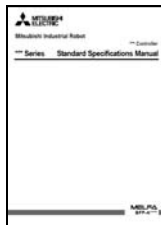

This is a printed version of the CD-ROM (instruction manual) supplied with this product.

■ Configuration

Table 3-38 : Product configuration

Name	Type	Mass (Kg) <sup>Note1)</sup>	Specifications
Instruction Manual	5F-FA01-PE01	2.6	The instructions manual set of "RH-3FH-D series".
Safety Manual	BFP-A8006	-	Items relating to safety in handling the robot
Standard Specifications	BFP-A8878	-	Specification of the robot arm and controller
Robot Arm Setup & Maintenance	BFP-A8865	-	Installation method of the robot arm, jog operation, and maintenance and inspection procedures
Controller Setup, Basic Operation and Maintenance	BFP-A8867	-	Installation method of the controller, basic operation, and maintenance and inspection procedures
Detailed Explanation of Functions and Operations	BFP-A8869	-	Functions of the controller and T/B, operation method, and explanation of MELFA-BASIC V
Troubleshooting	BFP-A8871	-	Causes of errors occurred and their countermeasures
Additional axis function	BFP-A8663	-	Function of the additional axis, operation method.
Tracking Function Manual	BFP-A8664	-	Function of the Tracking, operation method.
GOT Direct Connection Extended Function	BFP-A8849	-	Explains of data configuration of shared memory, monitoring, and operating procedures, between the GOT and controller.

Note1) Mass indicates one set.

### 3.11 Maintenance parts

The consumable parts used in the controller are shown in [Table 3-39](#). Purchase these parts from your dealer when required. Some Mitsubishi-designated parts differ from the maker's standard parts. Thus, confirm the part name, robot arm and controller serial No. and purchase the parts from your dealer.

Table 3-39 : Controller consumable parts list

No.	Name	Type <sup>Note1)</sup>	Qty.	Usage place	Supplier
1	Lithium battery	Q6BAT	1	CR750 controller: Inside of the interface cover CR751 controller: Inside of the filter cover	Mitsubishi Electric
2	Filter	CR750 controller: BKOFA0773H42 CR751 controller: BKOFA0773H41	1	Inside the filter cover	

Note1) Confirm the robot arm serial No., and contact the dealer or service branch of Mitsubishi Electric Co., for the type.

## 4 Software

## 4.1 List of commands

The available new functions in MELFA-BASIC V are given in [Table 4-1](#).

Table 4-1 : List of MELFA-BASIC V commands

Type	Class	Function	Input format (example)
Position and operation control	Joint interpolation	Moves to the designated position with joint interpolation.	Mov P1
	Linear interpolation	Moves to the designated position with linear interpolation.	Mvs P1
	Circular interpolation	Moves along a designated arc (start point → passing point → start point (end point)) with 3-dimensional circular interpolation (360 degrees).	Mvc P1,P2,P1
		Moves along a designated arc (start point → passing point → end point) with 3-dimensional circular interpolation.	Mvr P1,P2,P3
		Moves along the arc on the opposite side of a designated arc (start point → reference point → end point) with 3-dimensional circular interpolation.	Mvr2 P1,P9,P3
		Moves along a set arc (start point → end point) with 3-dimensional circular interpolation.	Mvr3 P1,P9,P3
		Speed designation	Designates the speed for various interpolation operations with a percentage (0.1% unit).
		Designate the speed for joint interpolation operation with a percentage (0.1% unit).	JOvrd 100
		Designates the speed for linear and circular interpolation with a numerical value (mm/s unit).	Spd 123.5
		Designates the acceleration/deceleration time as a percentage in respect to the predetermined maximum acceleration/deceleration. (1% unit)	Accel 50,80
		Automatically adjusts the acceleration/deceleration according to the parameter setting value.	Oadl ON
		Sets the hand and work conditions for automatic adjustment of the acceleration/deceleration.	Loadset 1,1
	Operation	Adds a process unconditionally to the operation.	Wth
		Adds a process conditionally to the operation.	WthIf
		Designates smooth operation.	Cnt 1,100,200
		Performance of movement is upgraded corresponding to the application.	MvTune 4
		Designates the positioning completion conditions with a No. of pulses.	Fine 200
		Designates the positioning completion conditions with a distance in a straight line	Fine 1, P
		Designates the positioning completion conditions with a joint interpolation.	Fine 0.5, J, 2
		Turns the servo power ON/OFF for all axes.	Servo OFF
		Limits the operation of each axis so that the designated torque is not exceeded.	Torq 4,10
	Position control	Designates the base conversion data.	Base P1
		Designates the tool conversion data.	Tool P1
	Float control	The robot arm rigidity is lowered and softened. (XYZ coordinate system)	Cmp Pos ,&B00000011
		The robot arm rigidity is lowered and softened. (JOINT coordinate system)	Cmp Jnt ,&B00000011
		The robot arm rigidity is lowered and softened. (TOOL coordinate system)	Cmp Tool ,&B00000011
		The robot arm rigidity is returned to the normal state.	Cmp Off
		The robot arm rigidity is designated.	CmpG 1.0,1.0,1.0,1.0,1.0,1.0,1.0,1.0
	Pallet	Defines the pallet.	Def Plt 1,P1,P2,P3,P4,5,3,1
		Operates the pallet grid point position.	Plt 1,M1
	Singular point passage	Move to a specified position using linear interpolation passing through a singular point.	Mvs P1 Type 0,2

Type	Class	Function	Input format (example)
Program control	Branching	Branches unconditionally to the designated place.	GoTo 120
		Branches according to the designated conditions.	If M1=1 Then GoTo *L100 Else GoTo 20 End If
		Repeats until the designated end conditions are satisfied.	For M1=1 TO 10  Next M1
		Repeats while the designated conditions are satisfied.	While M1<10  WEnd
		Branches corresponding to the designated expression value.	On M1 GoTo *La1, *Lb2, *Lc3
		Executes program block corresponding to the designated expression value..	Select Case 1  Break Case 2  Break End Select
		Moves the program process to the next line.	Skip
	Collision detection	Set to enable/disable the collision detection.	ColChk ON/OFF
		Set the detection level of the collision detection.	ColLvl 100,80,.....
	Subroutine	Executes the designated subroutine. (Within program)	GoSub *L200
		Returns from the subroutine.	Return
		Executes the designated program.	CallP "P10",M1,P1
		Defines the program argument executed with the CALLP command.	FPrm M10,P10
		Executes the subroutine corresponding to the designated expression value.	On M1 GoSub *La1, *Lb2, *Lc3
	Interrupt	Defines the interrupt conditions and process.	Def Act 1, M1=1 GoTo *L100
		Enables/disables the interrupt.	Act 1=1
		Defines the start line of the program to be executed when an interrupt is generated from the communication line.	On Com(1) GoSub *L100
		Enables the interrupt from the communication line.	Com(1) On
		Disables the interrupt from the communication line.	Com(1) Off
		Stops the interrupt from the communication line.	Com(1) Stop
	Wait	Designates the wait time, and the output signal pulse output time. (0.01s unit)	Dly 0.5
		Waits until the variable becomes the designated value.	Wait M_In(1)=1
	Stop	Stops the program execution.	Hlt
Generates an error. During program execution, continue, stop or servo OFF can be designated.		Error 9000	
End	Ends the program execution.	End	
Hand	Hand open	Opens the designated hand.	HOpen 1
	Hand close	Closes the designated hand.	HClose 1
Input/output	Assignment	Defines the input/output variables.	Def IO PORT1=BIT,0
	Input	Retrieves the general-purpose input signal.	M1=M_In(1)
	Output	Calls out the general-purpose output signal.	M_Out(1)=0
Parallel execution	Mechanism designation	Acquires the mechanism with the designated mechanism No.	GetM 1
		Releases the mechanism with the designated mechanism No.	ReIM 1
	Selection	Selects the designated program for the designated slot.	XLoad 2,"P102"
	Start/stop	Carries out parallel execution of the designated program.	XRun 3,"100",0
		Stops parallel execution of the designated program.	XStp 3
	Returns the designated program's execution line to the head and enters the program selection enabled state.	XRst 3	



Type	Class	Function	Input format (example)
Others	Definition	Defines the integer type or real number type variable.	Def Inte KAISUU
		Defines the character string variable.	Def Char MESSAGE
		Defines the layout variable. (Up to 3-dimensional possible)	Dim PDATA(2,3)
		Defines the joint variable.	Def Jnt TAIHI
		Defines the position variable.	Def Pos TORU
	Clear	Clears the general-purpose output signal, variables in program, variables between programs, etc.	Clr 1
	File	Opens a file.	Open "COM1:" AS #1
		Closes a file.	Close #1
		Inputs data from a file.	Input# 1,M1
		Outputs data to a file.	Print# 1,M1
	Comment	Describes a comment.	Rem "ABC"
	Label	Indicates the branching destination.	*SUB1

## 4.2 List of parameters

Show the main parameter in the [Table 4-2](#).

Table 4-2 : List of parameters

Parameter		Details
Standard tool coordinates.	MEXTL	Set the default value for the tool data. Unit: mm or deg.
Standard base coordinates	MEXBS	Set the relation of the world coordinate system and robot coordinate system. Unit: mm or deg.
XYZ operation range	MEPAR	Designate the overrun limit value for the world coordinate system.
JOINT operation range	MEJAR	Set the overrun limit value for each joint axis.
Free plane limit		This is the overrun limit set with the free plane. Create a plane with the three coordinates x1, y1, z1 to x3, y3, z3, and set the outer side of the plane as the outside operation range (error). The following three types of parameters are used.
	SFC1P : SFC8P	Eight types of free plane limits can be set in SFC1P to SFC8P. There are nine elements, set in the order of x1, y1, z1, x2, y2, z2, x3, y3, z3.
	SFC1ME : SFC8ME	Designate which mechanism to use eight types of set free plane limits. The mechanism No. to use is set with 1 to 3.
	SFC1AT : SFC8AT	Set the validity of the eight types of set free plane limits. (Valid 1/Valid 2/invalid = 1/-1/0)
User-defined area		An area (cube) defined with two XYZ coordinate points can be designated and that area set as the outside operation range. Furthermore, a signal can be output when the axis enters that area. Up to 32 types of area can be designated.
	AREA1CS : AREA32CS	Specify the coordinate system of the user definition area *. 0: Base coordinate system (conventional compatibility) 1: Robot coordinate system
	AREA1P1 : AREA32P1	Designated the 1st point of the area. There are eight elements, set in the order of x, y, z, a, b, c, L1, L2. (L1 and L2 are the additional axes.)
	AREA1P2 : AREA32P2	Designated the 2nd point of the area. There are eight elements, set in the order of x, y, z, a, b, c, L1, L2. (L1 and L2 are the additional axes.)
	AREA1ME : AREA32ME	Designate which mechanism to use the 32 types of set area. The mechanism No. to use is set with 1 to 3.
	AREA1AT : AREA32AT	Designate the area check type. (Invalid/zone/interference = 0/1/2) Zone: The dedicated output signal USRAREA turns ON. Interference: An error occurs..
Automatic return setting	RETPATH	Set to restart the program after returning to the interrupt position when resuming operation after an interruption.
Buzzer ON/OFF	BZR	Designate whether to the turn buzzer ON or OFF.
Jog setting	JOGJSP	Designate the joint jog and step operation speed. (Set dimension H/L amount, max. override.)
	JOGPSP	Designate the linear jog and step operation speed. (Set dimension H/L amount, max. override.)
Jog speed limit value	JOGSPMX	Limit the operation speed during the teaching mode. Max. 250[mm/s]
Hand type	HANDTYPE	Set the hand type of the single/double solenoid, and the signal No. (Single/double = S/D) Set the signal No. after the hand type. Example) D900
Stop input B contact designation	INB	Change the dedicated input (stop) to either of normal open or normal close.

Parameter		Details
User-designated origin	USERORG	Designate the user-designated origin position.
Program selection memory	SLOTON	Select the program selected previously when initializing the slot. The non-selected state will be entered when not set.
Communication setting	CBAU232	Set the baud rate.
	CLEN232	Set the character length.
	CPRTY232	Set the parity.
	CSTOP232	Set the stop bit.
	CTERM232	Set the end code.
Slot table	SLT1 : SLT32	Make settings (program name, operation type, order of priority, etc.) for each slot during slot initialization.
No. of multi-tasks	TASKMAX	Designate the No. of programs to be executed simultaneously. (Max. 32)
Select the function of singular point adjacent alarm	MESNGLS W	Designate the valid/invalid of the singular point adjacent alarm. (Invalid/Valid = 0/1) When this parameter is set up "VALID", this warning sound is buzzing even if parameter: BZR (buzzer ON/OFF) is set up "OFF".
Display language.	LNG	Change the language to display on the LCD display of teaching pendant.

## 5 Instruction Manual

### 5.1 The details of each instruction manuals

The contents and purposes of the documents enclosed with this product are shown below. Use these documents according to the application.

Instruction manuals enclosed in dashed lines in the list below are for optional products.

For special specifications, a separate instruction manual describing the special section may be enclosed.

Safety Manual	Explains the common precautions and safety measures to be taken for robot handling, system design and manufacture to ensure safety of the operators involved with the robot.
Standard Specifications	Explains the product's standard specifications, factory-set special specifications, option configuration and maintenance parts, etc. Precautions for safety and technology, when incorporating the robot, are also explained.
Robot Arm Setup & Maintenance	Explains the procedures required to operate the robot arm (unpacking, transportation, installation, confirmation of operation), and the maintenance and inspection procedures.
Controller Setup, Basic Operation and Maintenance	Explains the procedures required to operate the controller (unpacking, transportation, installation, confirmation of operation), basic operation from creating the program to automatic operation, and the maintenance and inspection procedures.
Detailed Explanation of Functions and Operations	Explains details on the functions and operations such as each function and operation, commands used in the program, connection with the external input/output device, and parameters, etc.
Troubleshooting	Explains the causes and remedies to be taken when an error occurs. Explanations are given for each error No.
Additional axis function	Explains the specifications, functions and operations of the additional axis control.
Tracking Function Manual	Explains the control function and specifications of conveyor tracking
Extended Function Instruction Manual	Explains the detailed description of data configuration of shared memory, monitoring, and operating procedures, about the PLC(CR750-Q/CR751-Q controller) and the GOT(CR750-D/CR751-D controller).

## 6 Safety

### 6.1 Safety

Measures to be taken regarding safety of the industrial robot are specified in the "Labor Safety and Sanitation Rules". Always follow these rules when using the robot to ensure safety.

#### 6.1.1 Self-diagnosis stop functions

This robot has the self-diagnosis stop functions shown in [Table 6-1](#) and the stop functions shown in [Table 6-2](#) for safe use.

Table 6-1 : Self-diagnosis stop functions

No.	Function	Details	Remarks
1	Overload protection function	Activates when the total servo current time exceeds the specified value.	The drive circuit is shut off. The robot stops, and an alarm displays.
2	Overcurrent diagnosis function	Activates when an overcurrent flows to the motor circuit.	The drive circuit is shut off. The robot stops, and an alarm displays.
3	Encoder disconnection diagnosis function	Activates when the encoder cable is disconnected.	The drive circuit is shut off. The robot stops, and an alarm displays.
4	Deflection over diagnosis function	Activates when an error occurs between the command value and actual position, and the error exceeds the specified amount.	The drive circuit is shut off. The robot stops, and an alarm displays.
5	AC power voltage drop diagnosis function	Activates when the AC power voltage drops below the specified value.	The drive circuit is shut off. The robot stops, and an alarm displays.
6	CPU error detection function	Activates when an error occurs in the CPU.	The drive circuit is shut off. The robot stops, and an alarm displays.
7	Overrun prevention function	Software limit detection	This is the limit provided by the software to enable operation only in the operation range.
		Mechanical stopper	This is the mechanical stopper provided outside the software.

Table 6-2 : List of stop functions

Stop function	Operation panel <sup>Note1)</sup>	Teaching pendant	External input	Details
Emergency stop	○	○	○	This is the stop with the highest degree of emergency. The servo power is shut off, and the mechanical brakes (all axes) activate to stop the robot. To recover, reset the alarm, and turn the servo ON with the servo ON command.
Stop	○	○	○	This is a stop operation with a high degree of emergency. The robot immediately decelerates and stops. Note that the servo power is not shut off. Use this when using the collision evasion sensor, etc.

Note1) Only CR750 controller has operation panel.

6.1.2 External input/output signals that can be used for safety protection measures

Table 6-3 : External input/output signals that can be used for safety protection measures

Signal	Connection point	Parameter	Functions	Usage method	
Input	External emergency stop <small>Note1)</small>	Connector (CR750 controller: CNSUSR11/12) (CR751 controller: CNSUSR1)	-	This servo power is shut off, and the robot stops immediately.	Externally installed emergency stop switch. Door switch on safety protection fence. Stopping at high-level error occurrence.
	Door switch		-		The door switch of the safe protection fence
	Enabling device input		-		Enabling device. The safety switch during teaching work
	Stop	Parallel I/O unit or interface	STOP	The program execution is stopped, and the robot stops. The servo power is not shut off.	The robot is stopped when a peripheral device fault occurs. The servo power is not shut off.
	Servo OFF		SRVOFF	The servo power can be shut off.	The robot is stopped when a peripheral device fault occurs. The servo power is not shut off.
	Automatic operation enable		AUTOENA	Disables automatic operation when inactive.	Door switch on safety protection fence
Output	Emergency stop output	Connector (CR750 controller: CNSUSR11/12) (CR751 controller: CNSUSR1)	-	Outputs the input signal of external emergency stop or emergency stop switch of T/B turned on.	Display and warn the pilot lamp, the input signal of external emergency stop or the emergency stop switch of T/B turned on.
	In servo ON	Parallel I/O unit or interface	SRVON	The servo power ON/OFF state is output.	The servo power ON/OFF state is shown and alerted with the display lamps.
	Waiting		STOP	Outputs that the robot is temporarily stopped.	The temporary stop state is shown and alerted with the display lamps.
	In alarm	Connector CR750/CR751 controller: (CNSUSR2)	ERRRESET -	Outputs when an alarm occurs in the robot.	The alarm state is shown and alerted with the display lamps.

Note1) The external emergency stop input is prepared as a normal close for safety proposes. Thus, if the emergency stop input circuit is opened when the robot is started up, the robot will not operate. Refer to [Page 139](#), "6.1.7 Examples of safety measures" for details.  
And, refer to [Page 90](#), "(3) Automatic Operation/Jog Operation/Brake Release and Necessary Switch Settings" for the function of the door switch input and the enabling device input.

6.1.3 Precautions for using robot

The safety measures for using the robot are specified in the "Labor Safety and Sanitation Rules". An outline of the rules is given below.

(1) Robot installation

- Secure sufficient work space required to safely perform work such as teaching and maintenance related to the robot.
- Install the controller outside the robot's motion space. (If a safety fence is provided, install outside the fence.)
- Install the controller where the entire robot operation can be viewed.
- Install display lamps, etc., to indicate the robot's operation state.
- Securely fix the robot arm onto the fixing table with the designated bolts.

(2) Prevention of contact with operator

- Install a safety fence or enclosure so that the operator cannot easily enter the robot's motion space.
- Install an interlock function that will stop the robot if the safety fence or enclosure door is opened.

(3) Work procedures

- Create and observe work procedures for the robot teaching, operation, inspection and emergencies.
- Create hand signals to be followed when several operators are working together.
- Create displays such as "Teaching in Progress" and "Inspection in Progress" to be put up when an operator is in the robot's motion space so that other operators will not operate the operation panel (controller, control panel).

(4) Training

- Train the operators about the operations, maintenance and safety required for the robot work.

- Only trained and registered operators must operate the robot. Participation in the "Special training for industrial robots" sponsored by the Labor Safety and Sanitation Committee, etc., is recommended for safety training.

(5) Daily inspection and periodic inspection

- Always inspect the robot before starting daily operations and confirm that there are no abnormalities.
- Set the periodic inspection standards in view of the robot's ambient environment and operation frequency, and perform periodic inspections.
- Make records when periodic inspections and repairs have been done, and store the records for three or more years.

6.1.4 Safety measures for automatic operation

- (1) Install safety fences so that operators will not enter the operation area during operation and indicate that automatic operation is in progress with lamps, etc.
- (2) Create signals to be given when starting operation, assign a person to give the signal, and make sure that the operator follows the signals.

6.1.5 Safety measures for teaching

Observe the following measures when teaching, etc., in the robot's operation range.

- (1) Specify and follow items such as procedures related to teaching work, etc.
- (2) Take measures so that operation can be stopped immediately in case of trouble, and measures so that operation can be restarted.
- (3) Take measures with the robot start switch, etc., to indicate that teaching work is being done.
- (4) Always inspect that stop functions such as the emergency stop device before starting the work.
- (5) Immediately stop the work when trouble occurs, and correct the trouble.
- (6) Take measures so that the work supervisor can immediately stop the robot operation when trouble occurs.
- (7) The teaching operator must have completed special training regarding safety. (Training regarding industrial robots and work methods, etc.)
- (8) Create signals to be used when several operators are working together.

6.1.6 Safety measures for maintenance and inspections, etc.

Turn the power OFF and take measures to prevent operators other than the relevant operator from pressing the start switch when performing inspections, repairs, adjustments, cleaning or oiling.

If operation is required, take measures to prevent hazards caused by unintentional or mistaken operations.

- (1) Specify and follow items such as procedures related to maintenance work, etc.
- (2) Take measures so that operation can be stopped immediately in case of trouble, and measures so that operation can be restarted.
- (3) Take measures with the robot start switch, etc., to indicate that work is being done.
- (4) Take measures so that the work supervisor can immediately stop the robot operation when trouble occurs.
- (5) The operator must have completed special training regarding safety. (Training regarding industrial robots and work methods, etc.)
- (6) Create signals to be used when several operators are working together.

## 6.1.7 Examples of safety measures

Two emergency-stop input circuits are prepared on the user wiring terminal block of the controller. Create a circuit as shown below for safety measures. In addition, the figure shows the normal state which is not in the emergency stop state.

[Caution] Since we have omitted the information in part because of explanation, there is the section different from the product. Also refer to [Page 149, "\(3\) External emergency stop connection \[supplementary explanation\]"](#).

[Note] · In the emergency-stop related wiring by the customer, if the coil (is not the contact points) of the relay prepared by the customer is connected to the controller, please be sure to implement the measure against the noise by the customer in the coil section. And, please also take the lifetime of noise suppression parts into consideration.

- Electric specification of the emergency-stop-related output terminal: 100mA/24V or less
- In the customer's system, do not ground the + side of 24V power supply prepared by customer for connect to the controller. (related with emergency stop and parallel input/output) If it connects with the controller under the condition that the + side is grounded, it will lead to failure of controller.

## (1) CR750 controller

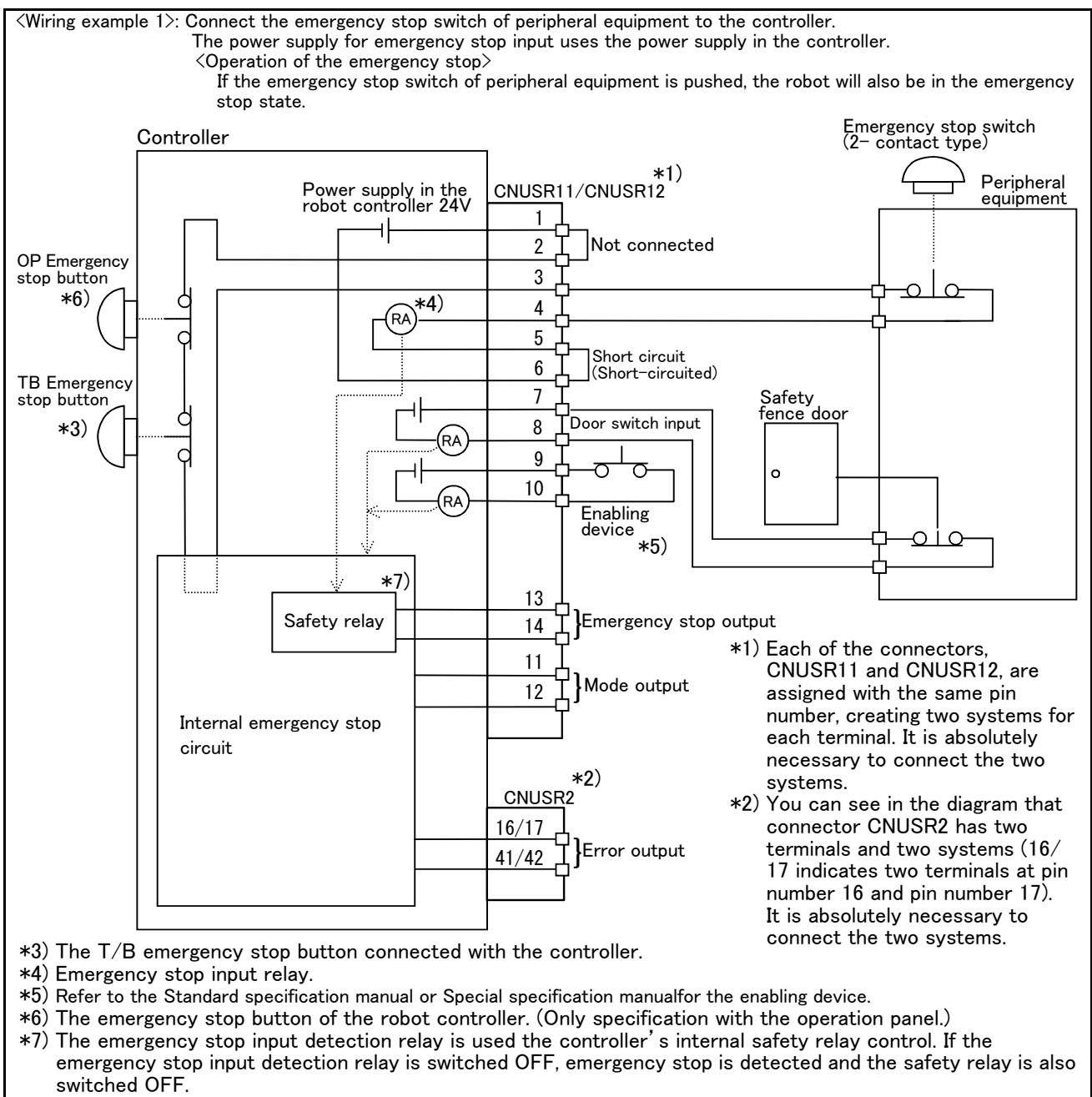
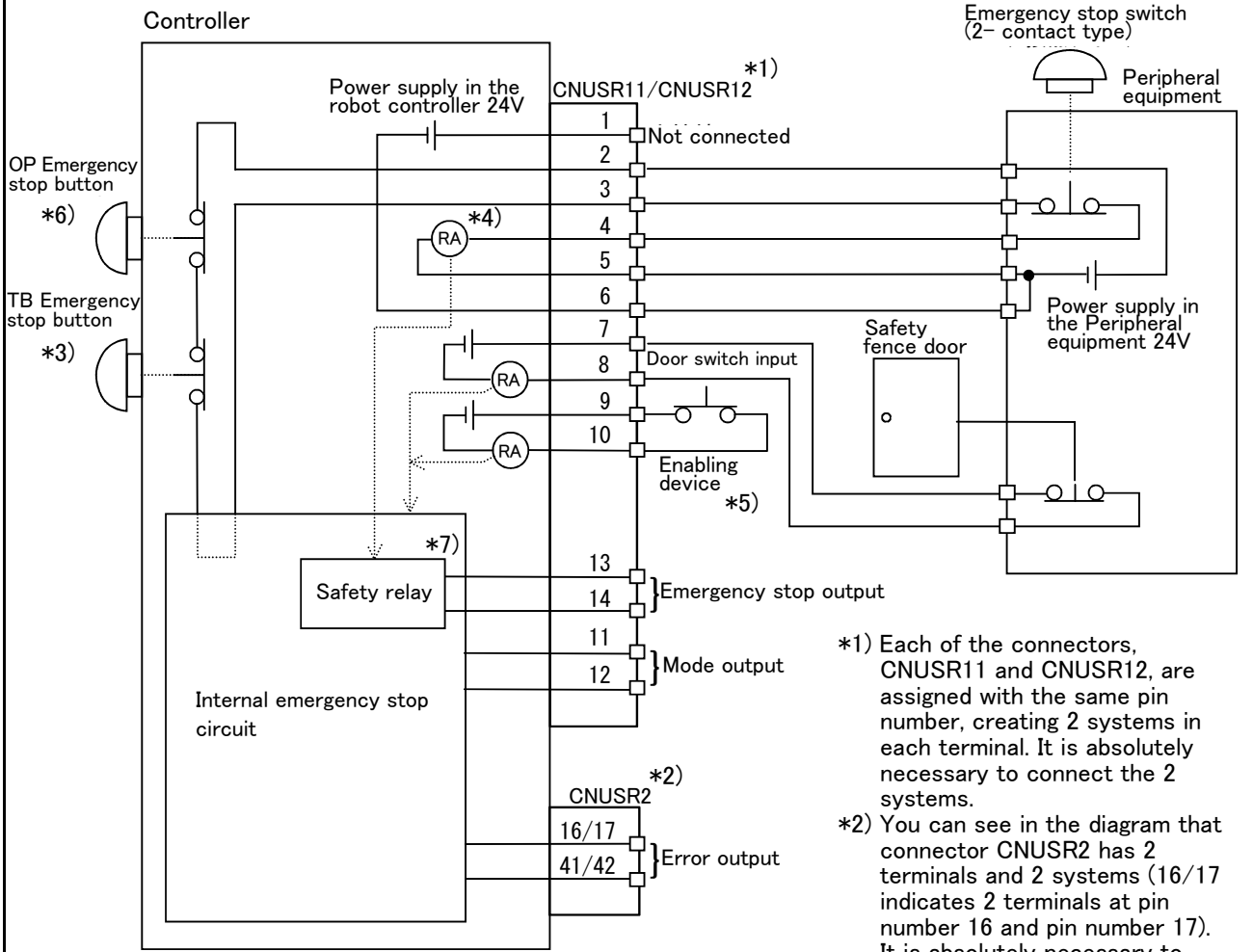

Fig.6-1 : Example of safety measures (CR750 wiring example 1)



<Wiring example 2>: Connect the emergency stop switch of peripheral equipment to the controller.  
 The power supply for emergency stop input uses the power supply of peripheral equipment.  
 <Operation of the emergency stop>  
 If the emergency stop switch of peripheral equipment is pushed, the robot will also be in the emergency stop state.



- \*1) Each of the connectors, CNUSR11 and CNUSR12, are assigned with the same pin number, creating 2 systems in each terminal. It is absolutely necessary to connect the 2 systems.
- \*2) You can see in the diagram that connector CNUSR2 has 2 terminals and 2 systems (16/17 indicates 2 terminals at pin number 16 and pin number 17). It is absolutely necessary to connect the 2 systems.

- \*3) The T/B emergency stop button connected with the controller.
- \*4) Emergency stop input relay.
- \*5) Refer to the Standard specification manual or the Special specification manual for the enabling device.
- \*6) The emergency stop button of the robot controller.  
(Only specification with the operation panel.)
- \*7) The emergency stop input detection relay uses the controller's internal safety relay control. If the emergency stop input detection relay is switched OFF, emergency stop is detected and the safety relay is also switched OFF.

Fig.6-2 : Example of safety measures (CR750 wiring example 2)

<Wiring example 3>: Connect the emergency stop switch, door switch, and enabling device of peripheral equipment to the controller. The power supply for emergency stop input uses the power supply of peripheral equipment. Monitor the emergency stop state by the peripheral equipment side.

<Operation of the emergency stop>

If the emergency stop switch of peripheral equipment is pushed, the robot will also be in the emergency stop state. And, if the emergency stop switch of OP or T/B is pushed in the state of the power of controller OFF, peripheral equipment state can be the emergency stop also.

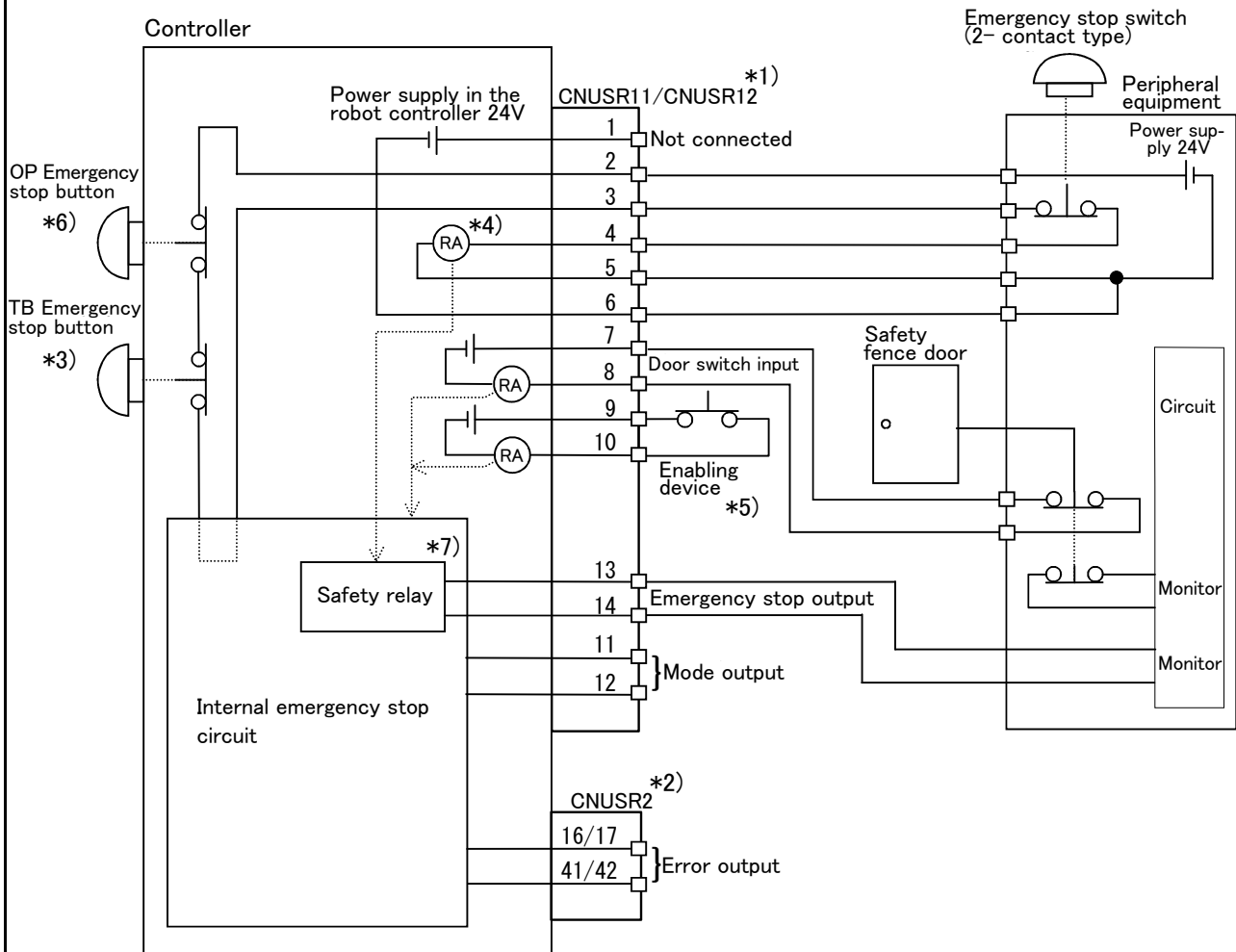

- \*1) Each of the connectors, CNUSR11 and CNUSR12, are assigned with the same pin number, creating 2 systems in each terminal. It is absolutely necessary to connect the 2 systems.
- \*2) You can see in the diagram that connector CNUSR2 has 2 terminals and 2 systems (16/17 indicates 2 terminals at pin number 16 and pin number 17). It is absolutely necessary to connect the 2 systems.
- \*3) The T/B emergency stop button connected with the controller.
- \*4) Emergency stop input relay.
- \*5) Refer to the Standard specification manual or the Special specification manual for the enabling device.
- \*6) The emergency stop button of the robot controller.  
(Only specification with the operation panel.)
- \*7) The emergency stop input detection relay uses the controller's internal safety relay control. If the emergency stop input detection relay is switched OFF, emergency stop is detected and the safety relay is also switched OFF.

Fig.6-3 : Example of safety measures (CR750 wiring example 3)

<Wiring example 4>: Connect the emergency stop switch of peripheral equipment, and the door switch to two controllers, and it interlocks. Connect the enabling device to the robot controller. The power supply for emergency stop input uses the power supply of peripheral equipment. Monitor the emergency stop state by the peripheral equipment side.

<Operation of the emergency stop>

If the emergency stop switch of peripheral equipment is pushed, the robot will also be in the emergency stop state. And, if the emergency stop switch of OP or T/B is pushed in the state of the power of controller OFF, peripheral equipment state can be the emergency stop also.

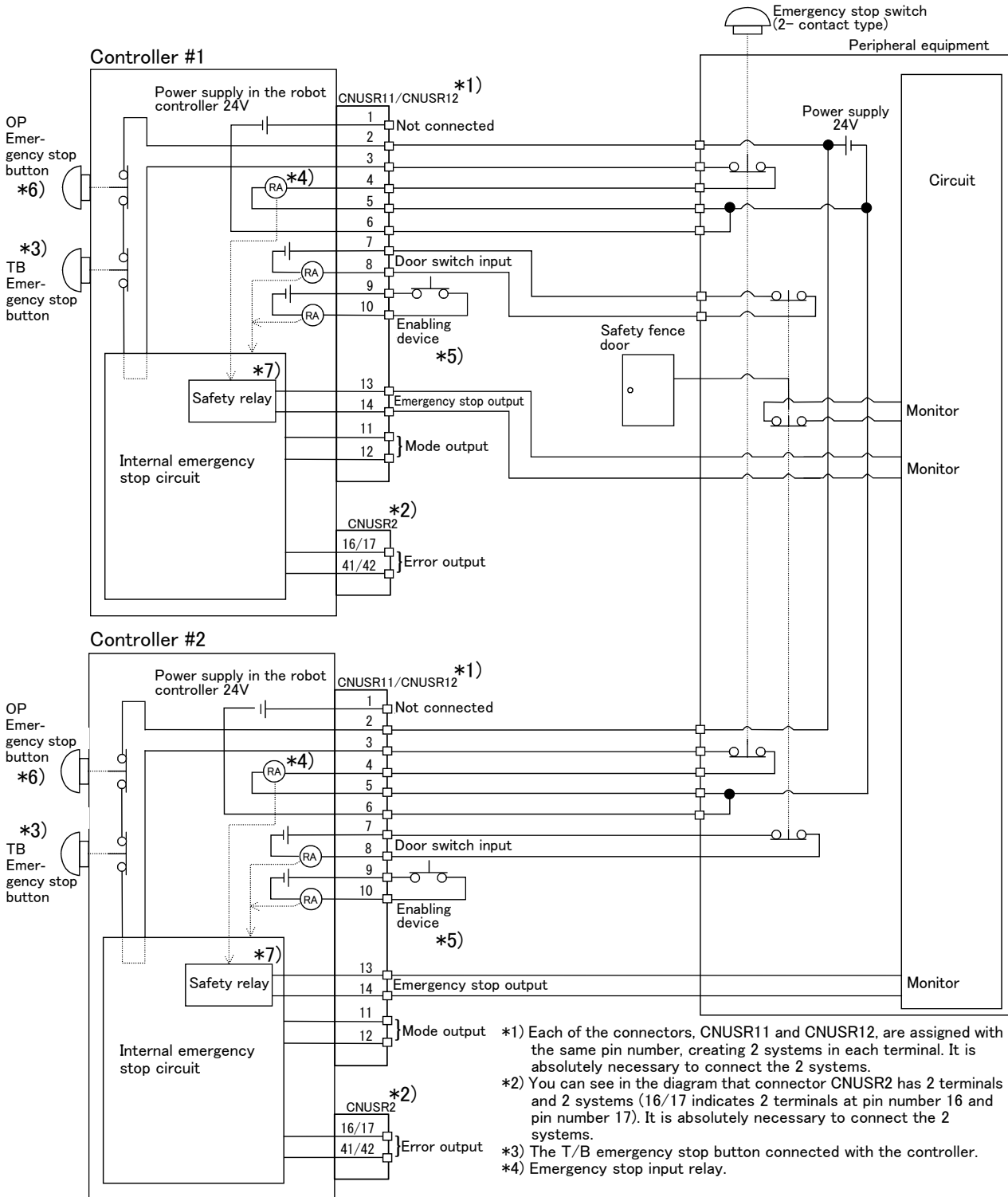

- \*1) Each of the connectors, CNUSR11 and CNUSR12, are assigned with the same pin number, creating 2 systems in each terminal. It is absolutely necessary to connect the 2 systems.
- \*2) You can see in the diagram that connector CNUSR2 has 2 terminals and 2 systems (16/17 indicates 2 terminals at pin number 16 and pin number 17). It is absolutely necessary to connect the 2 systems.
- \*3) The T/B emergency stop button connected with the controller.
- \*4) Emergency stop input relay.
- \*5) Refer to the Standard specification manual or the Special specification manual for the enabling device.
- \*6) The emergency stop button of the robot controller. (Only specification with the operation panel.)
- \*7) The emergency stop input detection relay uses the controller's internal safety relay control. If the emergency stop input detection relay is switched OFF, emergency stop is detected and the safety relay is also switched OFF.

Fig.6-4 : Example of safety measures (CR750 wiring example 4)

<Wiring example 5>: Connect the controller to the safety relay  
Use the controller's emergency stop button command as an input to the safety relay.

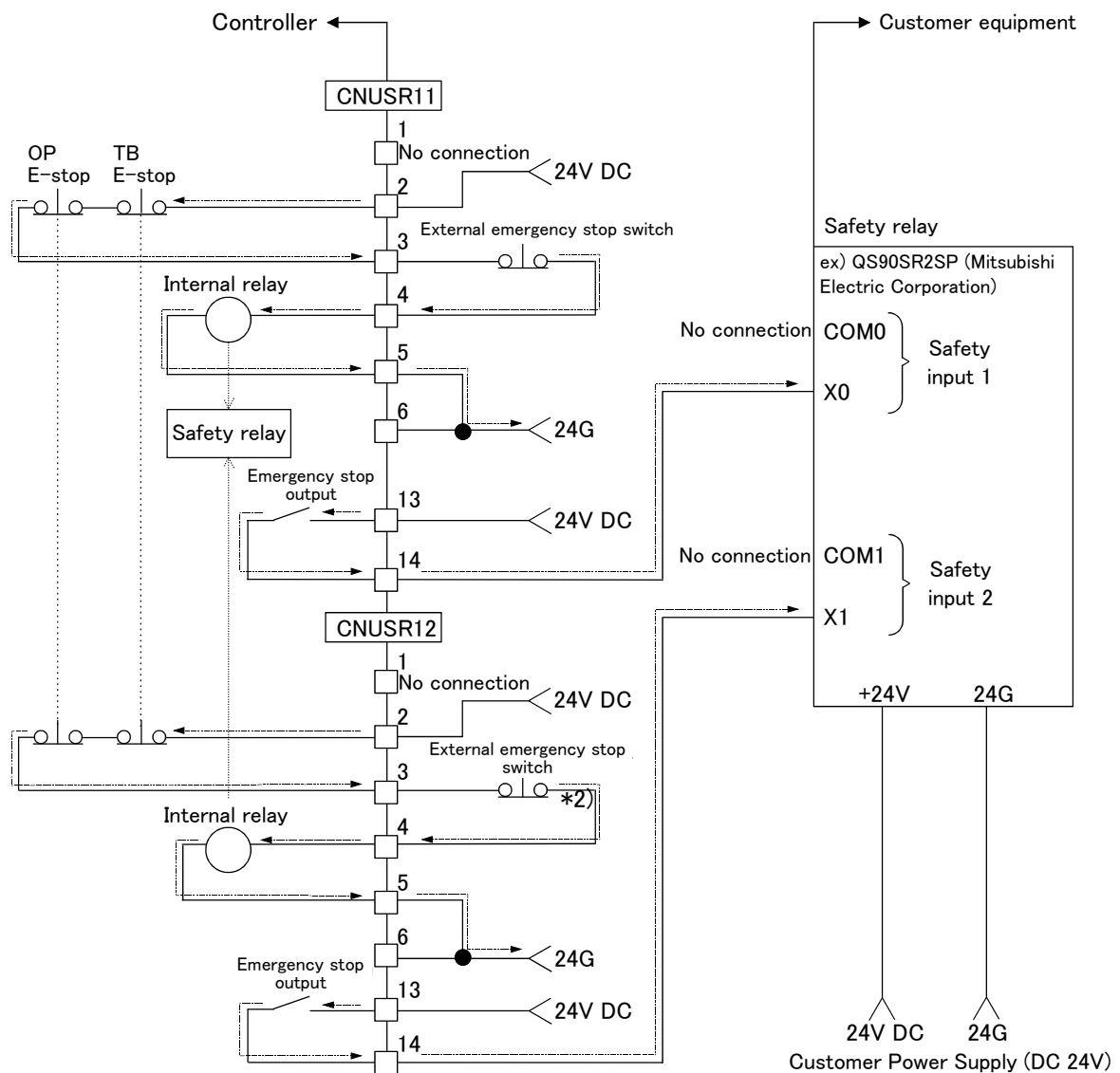

[Caution]

- 1) This product has category 3 functionality and therefore the robot's whole unit cannot be set to category 4.
- 2) The controller's internal circuit has polarity. Please adhere to the polarity as detailed in the wiring examples, particularly for emergency stop button output when using user equipment. Connect the positive side of the user equipment (24V DC) to the terminal 2 of CNUSR11/12, then connect the emergency stop button (or contact points) in the user equipment to across the terminals 3 and 4 of CNUSR11/12, and ultimately connect the negative side (24G).
- 3) When installing a safety relay to use it as an input point of the controller's emergency stop button command, use a safety relay that is activated by an input from one of the two systems (i.e. QS90SR2SP (Manufacture: Mitsubishi Electric Corporation)).
- 4) The emergency stop input detection relay (internal relay) uses the controller's internal safety relay control. If the emergency stop input detection relay is switched OFF, emergency stop is detected and the safety relay is also switched OFF.
- 5) When connecting emergency stop button output to an external safety relay, please take note of the polarity and make sure that the electrical current flows in the same direction as indicated by the dotted arrows in the two places in the diagram. If the polarity is setup incorrectly, this function will not operate correctly. Please connect the terminal 13 of CNUSR11/12 to 24V.

Fig.6-5 : Example of safety measures (CR750 wiring example 5)

(2) CR751 controller

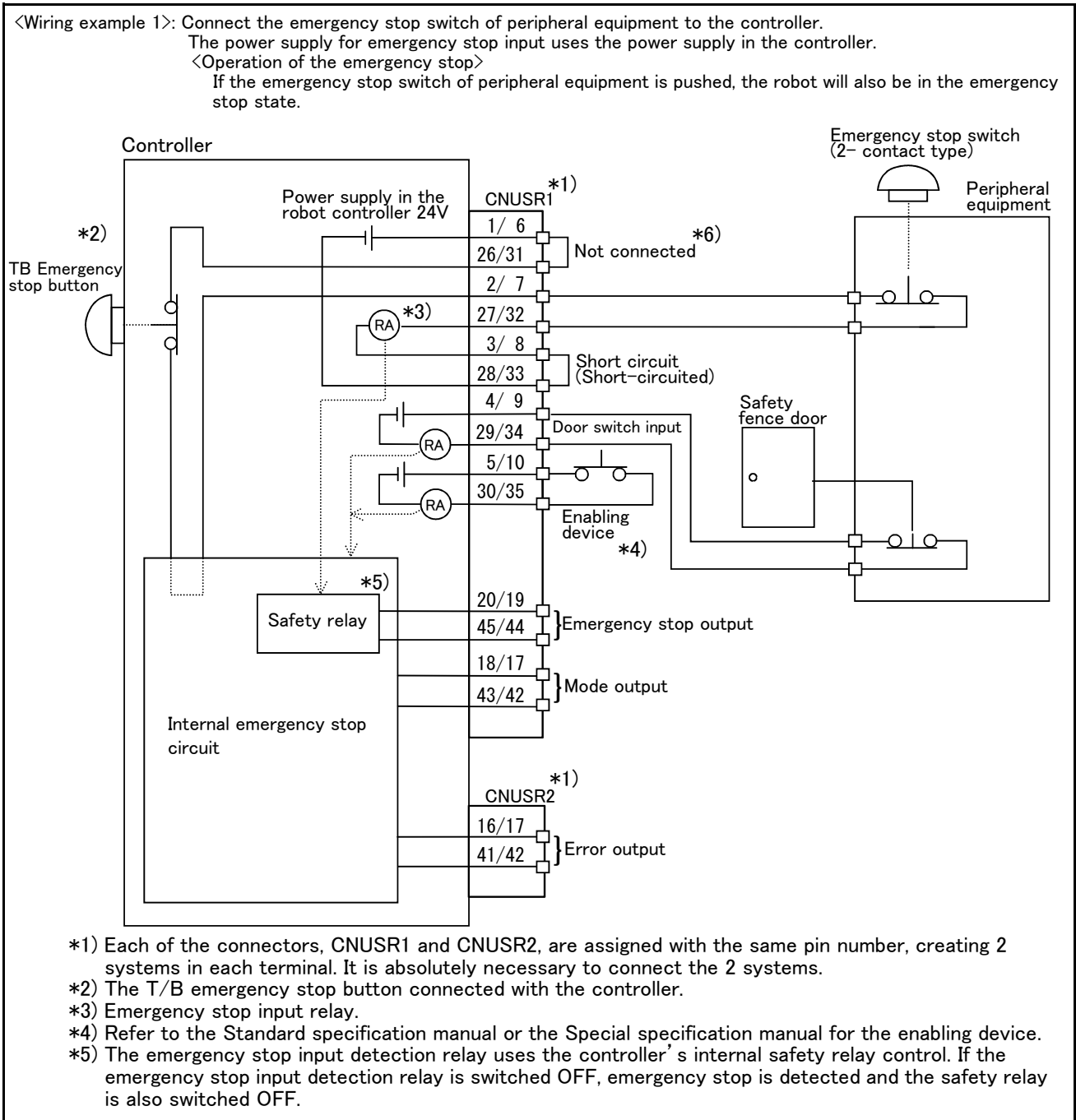
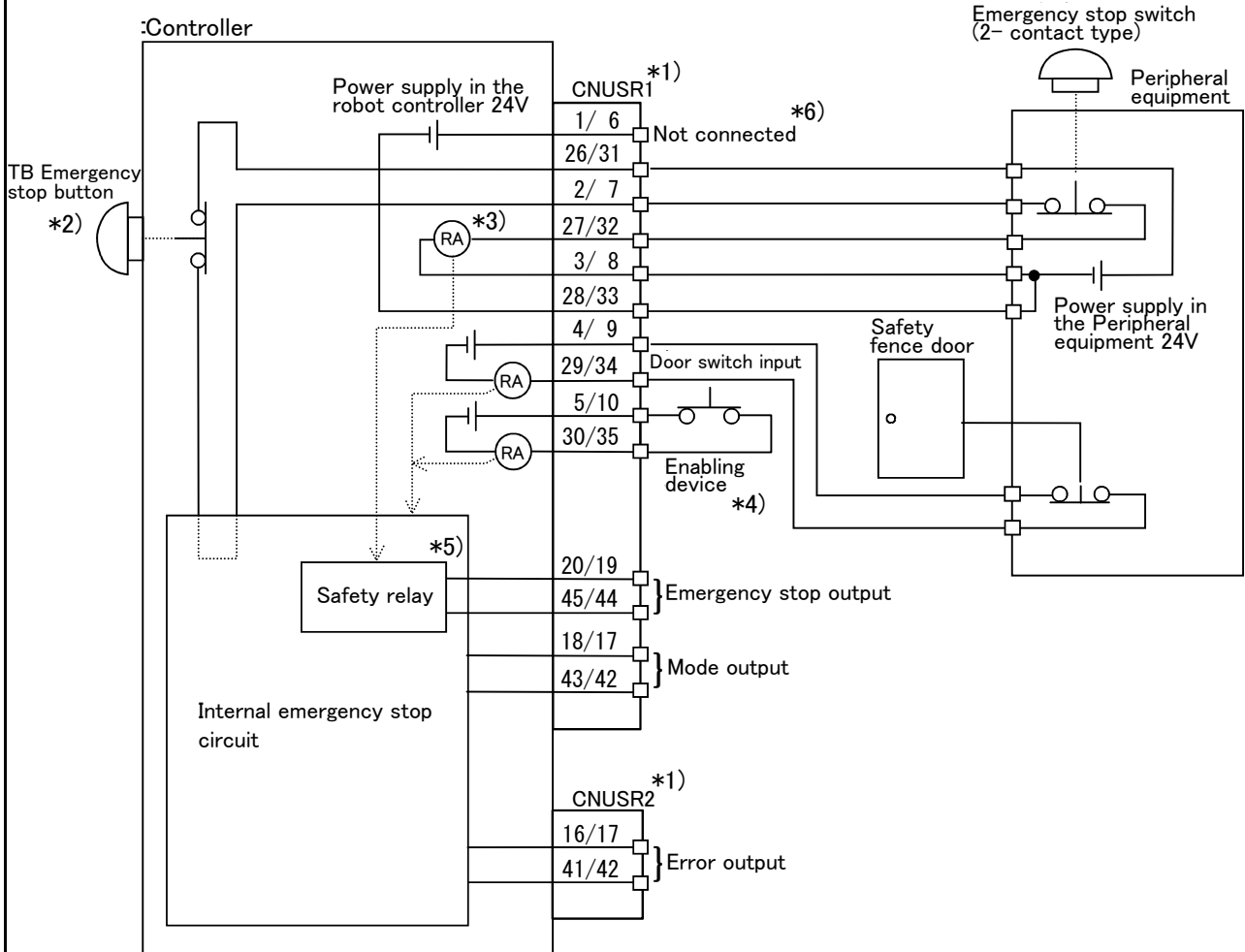

Fig.6-6 : Example of safety measures (CR751 wiring example 1)

<Wiring example 2>: Connect the emergency stop switch of peripheral equipment to the controller.  
 The power supply for emergency stop input uses the power supply of peripheral equipment.  
 <Operation of the emergency stop>  
 If the emergency stop switch of peripheral equipment is pushed, the robot will also be in the emergency stop state.



- \*1) Each of the connectors, CNUSR1 and CNUSR2, are assigned with the same pin number, creating 2 systems in each terminal. It is absolutely necessary to connect the 2 systems.
- \*2) The T/B emergency stop button connected with the controller.
- \*3) Emergency stop input relay.
- \*4) Refer to the Standard specification manual or the Special specification manual for the enabling device.
- \*5) The emergency stop input detection relay uses the controller's internal safety relay control. If the emergency stop input detection relay is switched OFF, emergency stop is detected and the safety relay is also switched OFF.
- \*6) Connect the 24V power supply to 26/31 terminals.

Fig.6-7 : Example of safety measures (CR751 wiring example 2)

<Wiring example 3>: Connect the emergency stop switch, door switch, and enabling device of peripheral equipment to the controller. The power supply for emergency stop input uses the power supply of peripheral equipment. Monitor the emergency stop state by the peripheral equipment side.  
 <Operation of the emergency stop>  
 If the emergency stop switch of peripheral equipment is pushed, the robot will also be in the emergency stop state. And, if the emergency stop switch of OP or T/B is pushed in the state of the power of controller OFF, peripheral equipment state can be the emergency stop also.

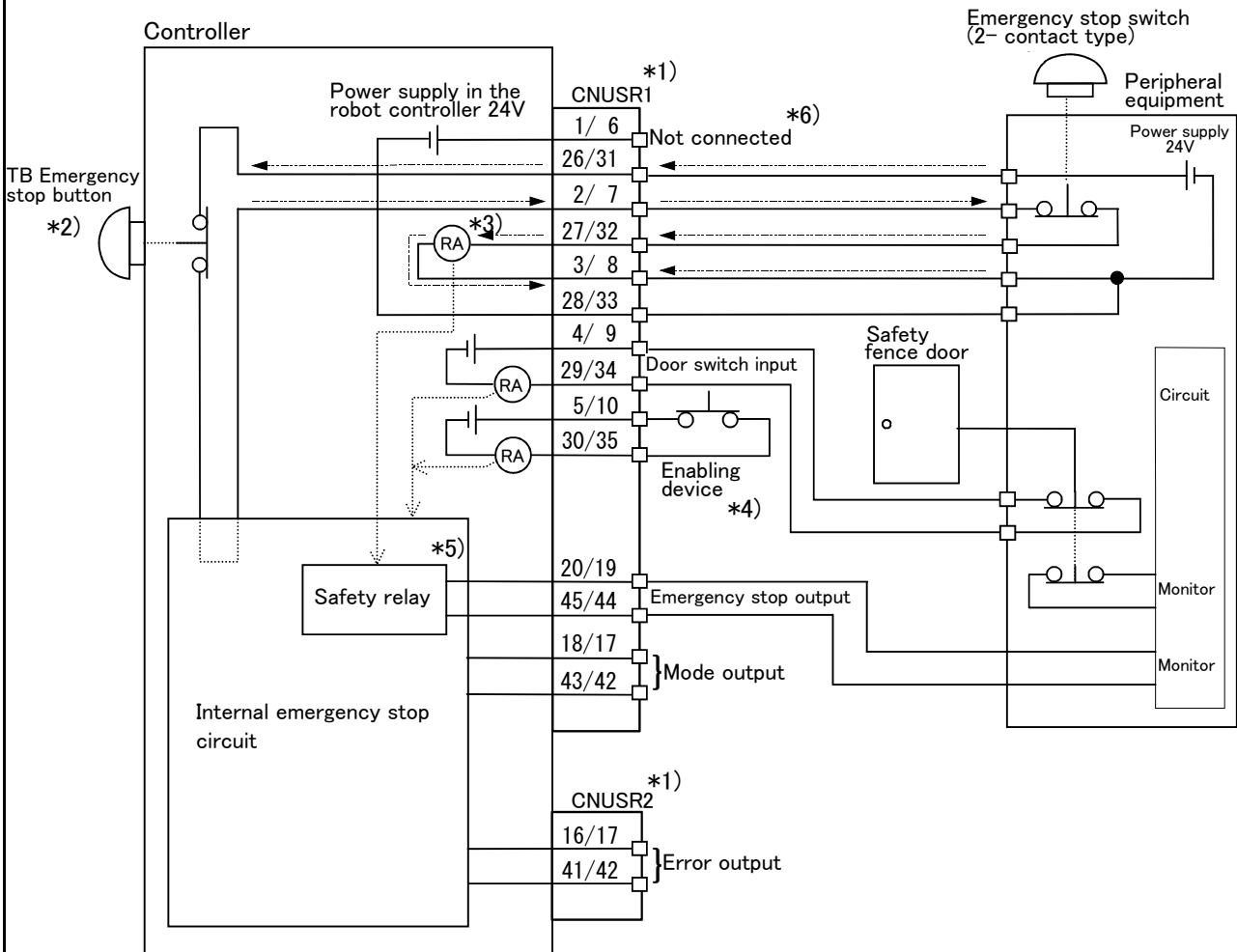

- \*1) Each terminal assigned with the respectively same pin number as connector: CNUSR1 and CNUSR2 and each is dual line. Always connect the two lines.
- \*2) The T/B emergency stop button connected with the controller.
- \*3) Emergency stop input relay.
- \*4) Refer to the Standard specification manual or the Special specification manual for the enabling device.
- \*5) The emergency stop input detection relay uses the controller's internal safety relay control. If the emergency stop input detection relay is switched OFF, emergency stop is detected and the safety relay is also switched OFF.
- \*6) Connect the 24V power supply to 26/31 terminals.

Fig.6-8 : Example of safety measures (CR751 wiring example 3)

<Wiring example 4>: Connect the emergency stop switch of peripheral equipment, and the door switch to two controllers, and it interlocks. Connect the enabling device to the robot controller. The power supply for emergency stop input uses the power supply of peripheral equipment. Monitor the emergency stop state by the peripheral equipment side.

<Operation of the emergency stop>

If the emergency stop switch of peripheral equipment is pushed, the robot will also be in the emergency stop state. And, if the emergency stop switch of OP or T/B is pushed in the state of the power of controller OFF, peripheral equipment state can be the emergency stop also.

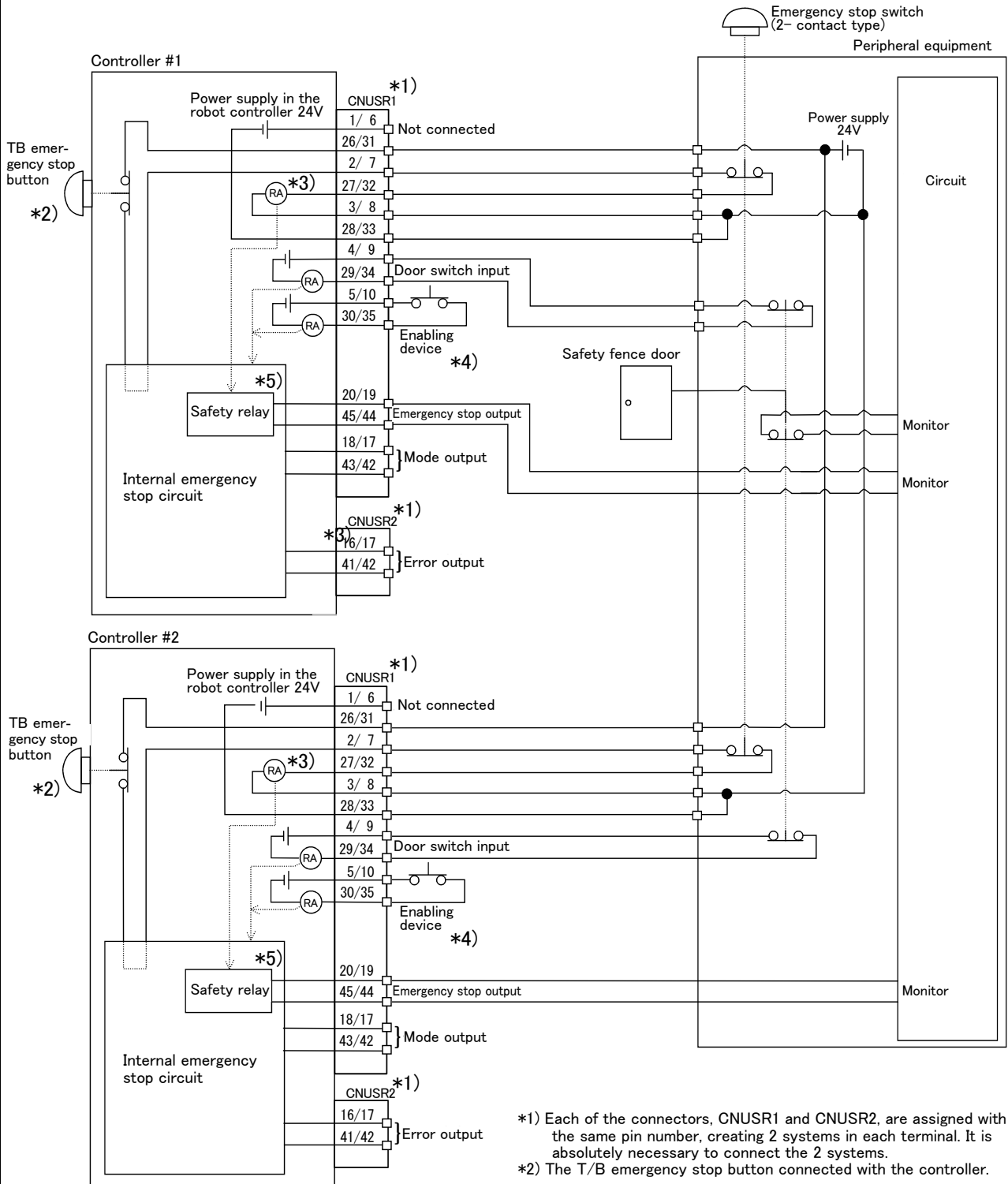

- \*1) Each of the connectors, CNUSR1 and CNUSR2, are assigned with the same pin number, creating 2 systems in each terminal. It is absolutely necessary to connect the 2 systems.
- \*2) The T/B emergency stop button connected with the controller.
- \*3) Emergency stop input relay.
- \*4) Refer to the Standard specification manual or the Special specification manual for the enabling device.
- \*5) The emergency stop input detection relay uses the controller's internal safety relay control. If the emergency stop input detection relay is switched OFF, emergency stop is detected and the safety relay is also switched OFF.

Fig.6-9 : Example of safety measures (CR751 wiring example 4)



<Wiring example 5>: Connect the controller to the safety relay  
 Use the controller's emergency stop button to input safety relay.

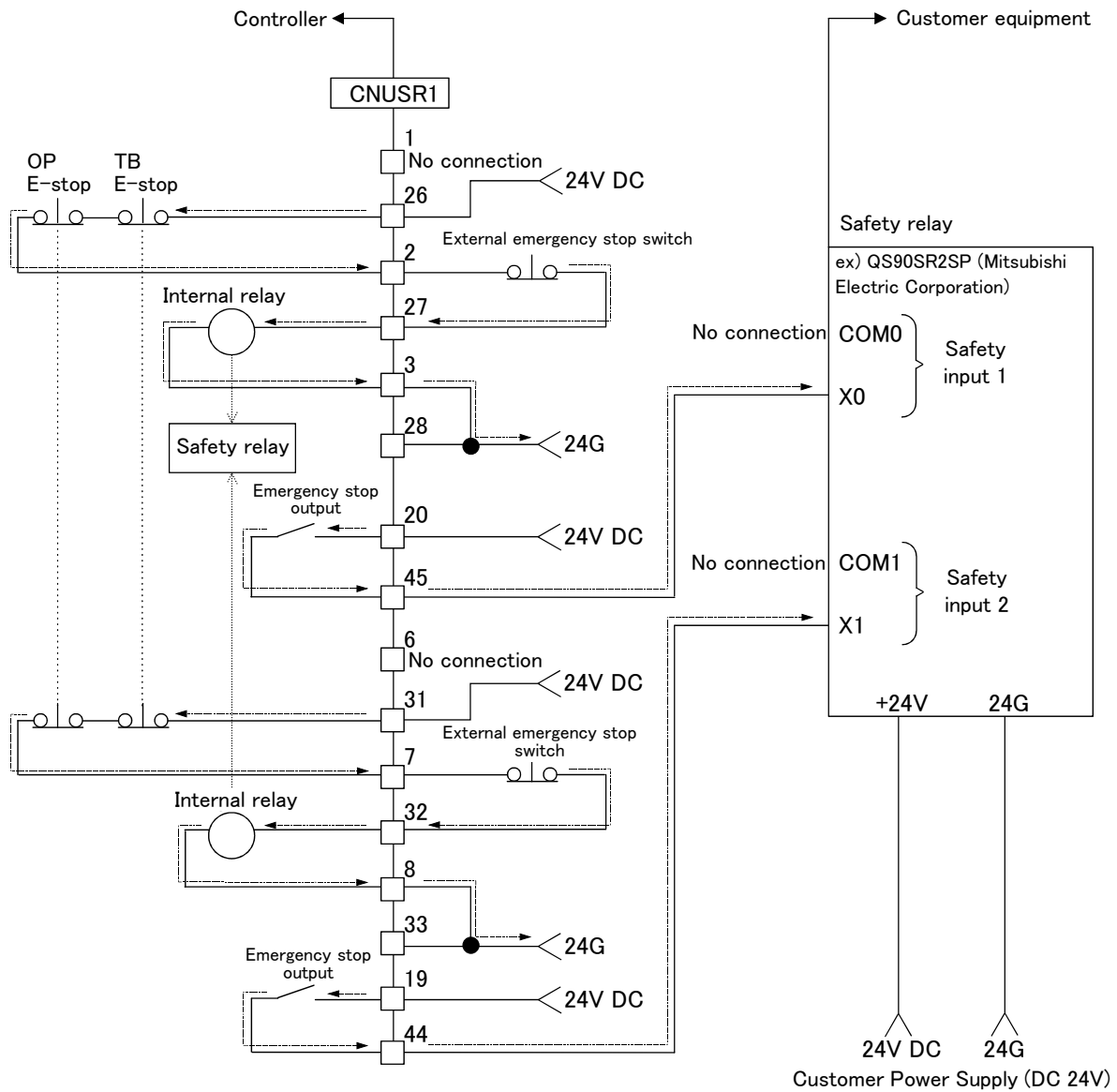

[Caution]

- 1) This product has category 3 functionality and therefore the robot's whole unit cannot be set to category 4.
- 2) The controller's internal circuit has polarity. Please adhere to the polarity as detailed in the wiring examples, particularly for emergency stop button output when using user equipment. Connect the positive side of the user equipment (24V DC) to the two terminals 26/31, then connect the emergency stop button (or contact points) in the user equipment to the 2-27 and 7-32 terminals, and ultimately connect to the negative side (24G).
- 3) Setup a safety relay on the user equipment, and when using to input the emergency stop button on the controller, please only use a safety relay that functions when connecting the input to the one end of the 2 systems (i.e. QS90SR2SP (Manufacture: Mitsubishi Electric Corporation)).
- 4) The emergency stop input detection relay (internal relay) uses the controller's internal safety relay control. If the emergency stop input detection relay is switched OFF, emergency stop is detected and the safety relay is also switched OFF.
- 5) When connecting emergency stop button output to an exterior safety relay, please take note of the polarity and make sure that the electrical current flows in the same direction as indicated by the dotted arrows in the two places in the diagram. If the polarity is setup incorrectly this function will not operate correctly. Please connect 20/19 terminal to 24V.

Fig.6-10 : Example of safety measures (CR751 wiring example 5)

## (3) External emergency stop connection [supplementary explanation]

- (1) Use a 2-contact type switch for all switches.
- (2) Install a limit switch on the safety fence's door. With a constantly open contact (normal open), wire to the door switch input terminal so that the switch turns ON (is conducted) when the door is closed, and turns OFF (is opened) when the door is open.
- (3) Use a manual-return type of normal close which have two lines for the emergency stop button.
- (4) Classify the faults into minor faults (faults that are easily restored and that do not have a great effect) and major faults (faults that cause the entire system to stop immediately, and that require care in restoration), and wire accordingly.

[Caution] The emergency stop input (terminal block) on the user wiring in the controller can be used for safety measures as shown in figure above. Note that there are limits to the No. of switch contacts, capacity and cable length, so refer to the following and install.

- Switch contact..... Prepare a 2-contact type. \*1)
- Switch contact capacity..... Use a normal open contact that operates with a switch contact capacity of approx. 1mA to 100mA/24V. \*1)  
If you connect the relay etc., rated current of the coil should use the relay which is 100mA/24V or less. (Refer to Fig. 6-12 and Fig. 6-11)
- Cable length..... The length of the wire between the switch and terminal block must be max. 15m or less. Please use the shield line, in case of the cable may receive the noise etc. by other equipment, such as servo amplifier. And, since the ferrite core is attached as noise measures parts, please utilize.

The size of the wire that fits to use is shown below.

- CR750 controller..... CNUSR11/12/13 connector:  
AWG #26 to #16 (0.14mm<sup>2</sup> to 1.5mm<sup>2</sup>)
- CR750 controller..... CNUSR2 connector:  
AWG #30 to #24 (0.05mm<sup>2</sup> to 0.2mm<sup>2</sup>)
- CR751 controller..... CNUSR1/2 connector:  
AWG #30 to #24 (0.05mm<sup>2</sup> to 0.2mm<sup>2</sup>)

Electric specification of the emergency stop related output circuit is 100mA/24V or less. Don't connect the equipment except for this range.

---

\*1) The minimum load electric current of the switch is more than 5mA/24V.

The electric-current value limitation when connecting the coils, such as the Relays (CR750 controller)

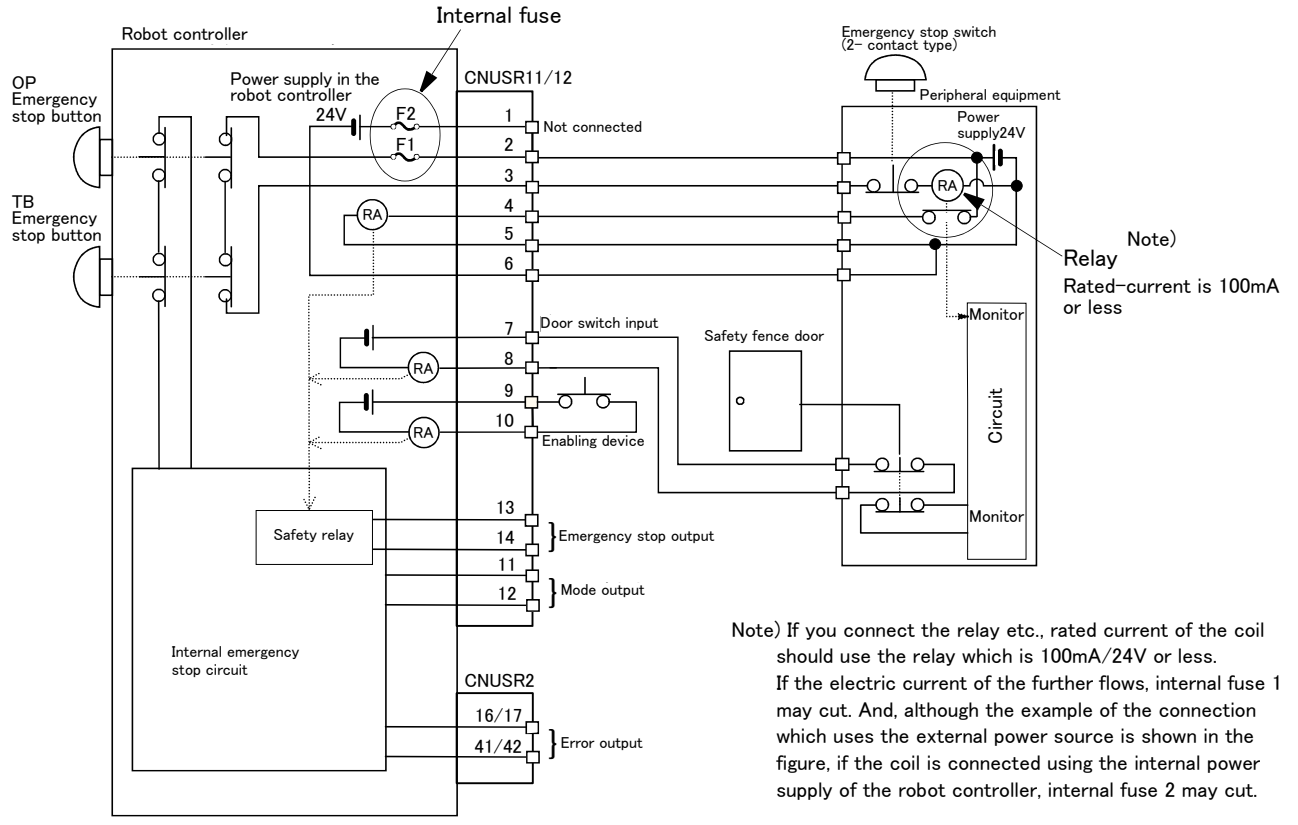

Fig.6-11 : Limitations when connecting the relay etc. (CR750)

The electric-current value limitation when connecting the coils, such as the Relays (CR751 controller)

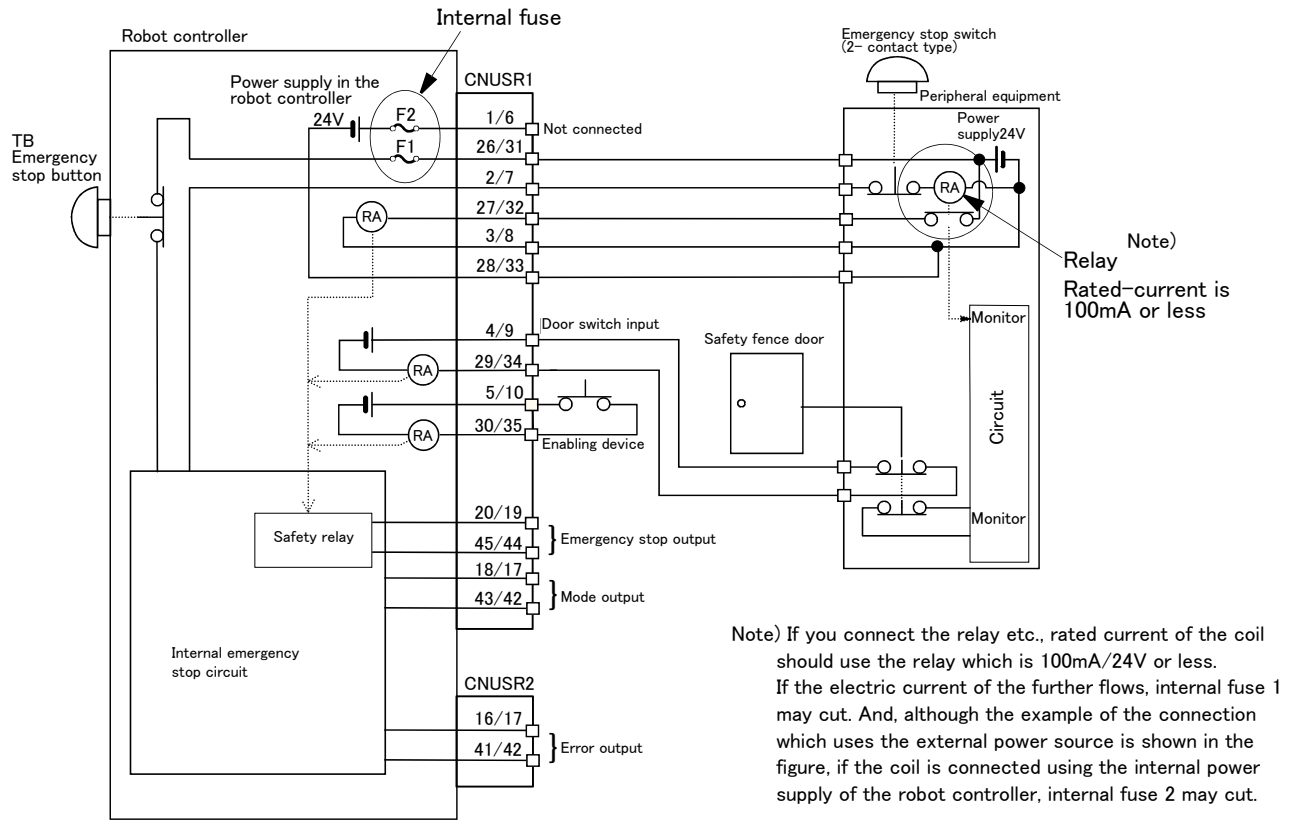
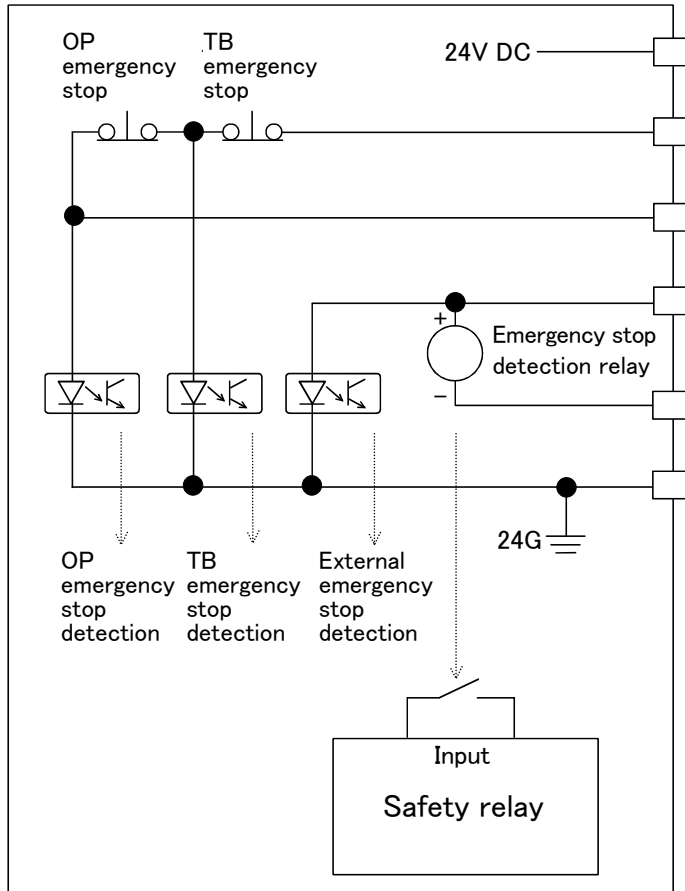

Fig.6-12 : Limitations when connecting the relay etc. (CR751)

[Supplementary explanation regarding emergency stop circuit]

The controller's internal circuit is as shown in the below diagram. Be sure to build a circuit that properly shuts off the emergency stop detection relay when the emergency stop button is pressed.



**CAUTION** Be sure to perform wiring correctly. If there are mistakes in the wiring, the robot may not stop when the emergency stop button is pressed and there will be a risk of damage or personal injury occurring. After wiring, be sure to press each of the installed emergency stop switches and check whether the emergency stop circuit works properly.

**CAUTION** Be sure to duplicate connection of the emergency stop, door switch and enabling switch. If not duplicated, these functions may fail due to a broken relay used by customer, etc.

## 6.2 Working environment

Avoid installation in the following places as the equipment's life and operation will be affected by the ambient environment conditions. When using in the following conditions, the customer must pay special attention to the preventive measures.

### (1) Power supply

- Where the voltage fluctuation will exceed the input voltage range.
- Where a momentary power failure exceeding 20ms may occur.
- Where the power capacity cannot be sufficiently secured.

### CAUTION

Please use the controller with an input power supply voltage fluctuation rate of 10% or less. In the case of 200 VAC input, for example, if the controller is used with 180 VAC during the day and 220 VAC during the night, turn the servo off once and then on again. If this is not performed, an excessive regeneration error may occur.

### (2) Noise

- Where a surge voltage exceeding 1000V, 1  $\mu$  s may be applied on the primary voltage. Near large inverters, high output frequency oscillator, large contactors and welding machines. Static noise may enter the lines when this product is used near radios or televisions. Keep the robot away from these items.

### (3) Temperature and humidity

- Where the atmospheric temperature exceeds 40 degree , lower than 0 degree.
- Where the relative humidity exceeds 85%, lower than 45%, and where dew may condense.
- Where the robot will be subject to direct sunlight or near heat generating sources such as heaters.

### (4) Vibration

- Where excessive vibration or impact may be applied. (Use in an environment of 34m/s<sup>2</sup> or less during transportation and 5m/s<sup>2</sup> or less during operation.)

### (5) Installation environment

- Where strong electric fields or magnetic fields are generated.
- Where the installation surface is rough. (Avoid installing the robot on a bumpy or inclined floor.)
- Where there is heavy powder dust and oil mist present.

## 6.3 Precautions for handling

- (1) This robot has brakes on J3 axes. The precision of the robot may drop, looseness may occur and the reduction gears may be damaged if the robot is moved with force with the brakes applied.
- (2) Avoid moving the robot arm by hand. When unavoidable, gradually move the arm. If moved suddenly, the accuracy may drop due to an excessive backlash, or the backed up data may be destroyed.
- (3) Note that depending on the posture, even when within the movement range, the shaft section could interfere with the base section. Take care to prevent interference during jog. <sup>\*1)</sup>
- (4) The robot arm consists of precision parts such as bearing. Lubricants such as grease are also applied on the moving parts to keep the mechanical accuracy. In a cold start under low temperature or in the first start after being stored for one month or longer, lubricants may not be spread enough. Such condition may lower the positioning accuracy, cause servo and overload alarms, and early wearing of the moving parts. To avoid such situation, perform warm-up operation of the machine at a low speed (at about 20% of normal operation speed). Move the robot arm from the lower to the upper limit of the movable range with the 30 degree joint angle or more for about 10 minutes. After that, speed up the operation gradually.  
Please use the warm-up operation. (About the details of the warm-up operation, refer to "INSTRUCTION MANUAL/Detailed explanations of functions and operations".)
- (5) When the air hoses and cables are used inside the shaft (J3 axis), the grease for cable protection may ooze out or abrasion powders may be generated from the tip of the shaft while the robot is moving. However, movements and performance of the robot are not affected. Wipe off the grease or powders as required.

---

\*1) Jog operation refers to operating the robot manually using the teaching pendant.

- (6) The robot arm and controller must be grounded with  $100\Omega$  or less (class D grounding) to secure the noise resistance and to prevent electric shocks.
- (7) The items described in these specifications are conditions for carrying out the periodic maintenance and inspections described in the instruction manual.
- (8) When using the robot arm on a mobile axis or elevating table, the machine cables enclosed as standard configuration may break due to the fixed installation specifications. In this case, use "the machine cable extension (for flexed)" factory shipment special specifications or options.
- (9) If this robot interferes with the workpiece or peripheral devices during operation, the position may deviate, etc. Take care to prevent interference with the workpiece or peripheral devices during operation.
- (10) Do not attach a tape or a label to the robot arm and the controller. If a tape or a label with strong adhesive power, such as a packaging tape, is attached to the coated surfaces of the robot arm and controller, the coated surface may be damaged when such tape or label is peeled off.
- (11) If the robot is operated with a heavy load and at a high speed, the surface of the robot arm gets very hot. It would not result in burns, however, it may cause secondary accidents if touched carelessly.
- (12) Do not shut down the input power supply to stop the robot. If the power supply is frequently shut down during a heavy load or high-speed operation, the speed reducer may be damaged, backlash may occur, and the program data may be destroyed.
- (13) During the robot's automatic operation, a break is applied to the robot arm when the input power supply is shut down by a power failure, for instance. When a break is applied, the arm may deviate from the operation path predetermined by automatic operation and, as a result, it may interfere with the mechanical stopper depending on the operation at shutdown. In such a case, take an appropriate measure in advance to prevent any dangerous situation from occurring due to the interference between the arm and peripheral devices.  
Example) Installing a UPS (uninterruptible power supply unit) to the primary power source in order to reduce interference.
- (14) Do not conduct an insulated voltage test. If conducted by mistake, it may result in a breakdown.
- (15) Fretting may occur on the axis which moving angle or moving distance move minutely, or not moves. Fretting is that the required oil film becomes hard to be formed if the moving angle is small, and wear occurs. The axis which not moved is moving slightly by vibration etc. To make no fretting recommends to move these axes about once every day the 30 degree or more, or the 20mm or more.
- (16) The United Nations' Recommendations on the Transport of Dangerous Goods must be observed for trans-border transportation of lithium batteries by air, sea, and land. The lithium batteries (ER6, Q6BAT) used in Mitsubishi industrial robots contain less than 1 g of lithium and are not classified as dangerous goods. However, if the quantity of lithium batteries exceeds 24 batteries for storage, etc., they will be classified as Class 9: Miscellaneous dangerous substances and articles. Shipping less than 24 batteries is recommended to avoid having to carry out transport safety measures as the customer's consignor. Note that some transportation companies may request an indication that the batteries are not dangerous goods be included on the invoice. For shipping requirement details, please contact your transportation company.
- (17) If the air supply temperature (primary piping) used for the tool etc. is lower than ambient air temperature, the dew condensation may occur on the coupling or the hose surface.
- (18) Collision detection function is valid condition for both of automatic and jog operation at shipping. So, the robot stops immediately if the robot's tool or arm interferes with a peripheral device, minimizing damage. Therefore, please use in the valid condition.
- (19) When fumigants that contain halogen materials such as fluorine, chlorine, bromine, and iodine are used for disinfecting and protecting wooden packaging from insects, they cause malfunction when entering our products. Please take necessary precautions to ensure that remaining materials from fumigant do not enter our products, or treat packaging with methods other than fumigation (heat method). Additionally, disinfect and protect wood from insects before packing products.

## 6.4 EMC installation guideline

### 6.4.1 Outlines

The EMC directive is coerced from January 1, 1996, and it is necessary to attach the CE mark which shows that the product is in conformity to directive.

Since the industrial robot is the component of the automation system, it considers that the EMC directive is not the target product of the direct. However, because it is one of the main components, introduces the method and components of the measures for conforming the automation system to the EMC directive.

And also we are carrying out the qualification test about the conformity of the EMC directive under the environment based on the contents of this document. However, the noise level is changed by the kind of equipment to be used, the layout, the construction of the controlling board, the course of wiring, etc. Therefore, please confirm by the customer eventually.

### 6.4.2 EMC directive

The Mitsubishi Electric industrial robot follows the European EMC directive. This technical standard regulates the following two items.

(1) Emission (EMI : Electromagnetic Interference).....The capacity not to generate the disturbance noise which has a bad influence outside.

(2) Immunity (EMS : Electromagnetic Susceptibility).....The capacity which does not malfunction for the disturbance noise from the outside.

Each contents are shown below.

Item	Name	Contents	Testing technical-standard number
Emission (EMI)	Radiative noise disturbance	The electromagnetic noise etc. which are emitted to environs.	EN61000-6-2 : 2005 EN61000-6-4 : 2007 EN62061:2005(Annex E)
	Electrical-conduction noise disturbance	The electromagnetism noise etc. which flow out of the power-supply line.	
Immunity (EMS)	Electrostatic discharge immunity test	The noise from the electrified human body.	
	Radiated, radio-frequency, electromagnetic field immunity test susceptibility test	The electromagnetism noise from the transceiver, the broadcasting station, etc.	
	Electrical fast transient burst immunity test	The relay noise or the electromagnetism noise etc. which are caused in power-supply ON/OFF.	
	Immunity to conducted disturbances induced radio-frequency fields	The electromagnetism noise etc. which flow in through the power source wire and the grounding wire.	
	Power frequency magnetic field immunity test	The electromagnetism noise with a power supply frequency of 50/60 Hz etc.	
	Voltage dips, short interruptions and voltage variations immunity test	The noise in the variation of the source voltage of the power dispatching, etc.	
	Surge immunity test	The electromagnetism noise by the thunderbolt, etc.	

6.4.3 EMC measures

There are mainly following items in the EMC measures.

- (1) Store into the sealed metal board.
- (2) Grounding all the conductor that have floated electrically (makes the impedance low).
- (3) Wiring so that the power source wire and signal wire are separated.
- (4) Use the shield cable for the cable which wired outside of the metal board.
- (5) Install the noise filter.

To suppress the noise emitted out of the board, be careful of the following item.

- (1) Ensure grounding of the equipment.
- (2) Use the shield cable.
- (3) Separate the metal board electrically. Narrows the distance/hole.

The strength of electromagnetic noise emitted to environment is changed a lot by the shielding efficiency of cable and the distance of metal board, so it should be careful.

6.4.4 Component parts for EMC measures

(1) Ferrite core

The ferrite core is mounted by the plastics case as one. It can attach by the one-touch, without cutting the cable. This has the effect in the common-mode noise. The measures against the noise are made not influential in the quality of the signal.

There are the following as an example.

Maker: SEIWA ELECTRIC MFG. Co.,Ltd.

Type	Outside dimension (mm)				Diameter of the adaptation cable [max] (mm)
	A	B	C	D	
E04SR401938	61	38	19	40	19.0
E04SR301334	39	34	13	30	13.0

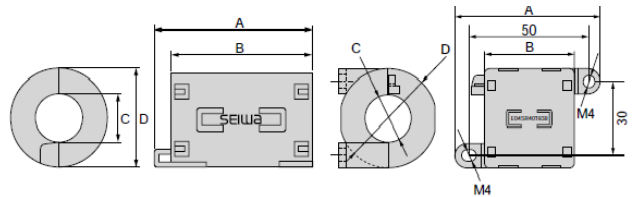

Maker: TAKACHI ELECTRONICS ENCLOSURE CO., LTD.

Type	Outside dimension (mm)				Diameter of the adaptation cable [max] (mm)
	A	B	C	D	
TFT-274015S	43.8	27.4	20.7	-	φ 26.5

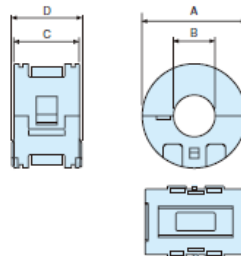

(2) Line noise filter

Type : FR-BLF (Mitsubishi Electric Corp.)

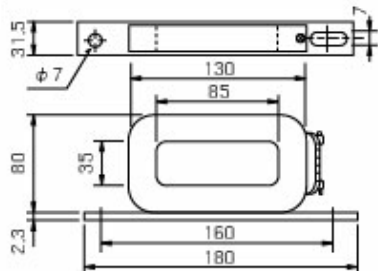



## 7 Appendix

## Appendix 1 : Specifications discussion material

## ■ Customer information

Company name		Name	
Address		Telephone	

## ■ Purchased model

Item	Type	Arm length	Stroke	Controller
General specification	RH-3FH <input type="checkbox"/> <input type="checkbox"/> 15-1D	<input type="checkbox"/> 350 <input type="checkbox"/> 450 <input type="checkbox"/> 550	<input checked="" type="checkbox"/> 150	CR751-03HD-0
Clean specification	RH-3FH <input type="checkbox"/> <input type="checkbox"/> 12C-1D	<input type="checkbox"/> 350 <input type="checkbox"/> 450 <input type="checkbox"/> 550	<input checked="" type="checkbox"/> 120	

## ■ Shipping special specifications

Item	Standard specification	Special shipping specifications
Robot arm	Machine cable	<input type="checkbox"/> 5m fixed type 2m fixed type: <input type="checkbox"/> 1S-02UCBL-03 (For CR750 controller) <input type="checkbox"/> 1F-02UCBL-02 (For CR751 controller)
	CE Marking specification	<input type="checkbox"/> Not provided <input type="checkbox"/> -S15 (with CR750 controller) <input type="checkbox"/> -S15 (with CR751 controller)

## ■ Options (Installable after shipment)

Item	Type	Provision, and specifications when provided.	
Robot arm	J1 axis operating range change	1F-DH-01 <input type="checkbox"/> Not provided <input type="checkbox"/> Provided	
	Machine cable extension (extension type)	1S- <input type="checkbox"/> <input type="checkbox"/> CBL-03	Fixed type (For CR750 controller): <input type="checkbox"/> Not provide <input type="checkbox"/> 5m <input type="checkbox"/> 10m <input type="checkbox"/> 15m
		1S- <input type="checkbox"/> <input type="checkbox"/> LCBL-03	Flexed type (For CR750 controller): <input type="checkbox"/> Not provide <input type="checkbox"/> 5m <input type="checkbox"/> 10m <input type="checkbox"/> 15m
	Machine cable extension (direct type)	1S- <input type="checkbox"/> <input type="checkbox"/> LUCBL-03	Flexed type (For CR750 controller): <input type="checkbox"/> Not provide <input type="checkbox"/> 5m <input type="checkbox"/> 10m <input type="checkbox"/> 15m
		1F- <input type="checkbox"/> <input type="checkbox"/> UCBL-02	Fixed type (For CR751 controller): <input type="checkbox"/> Not provide <input type="checkbox"/> 10m <input type="checkbox"/> 15m <input type="checkbox"/> 20m
	1F- <input type="checkbox"/> <input type="checkbox"/> LUCBL-02	Flexed type ((For CR751 controller): <input type="checkbox"/> Not provide <input type="checkbox"/> 10m <input type="checkbox"/> 15m <input type="checkbox"/> 20m	
	Solenoid valve set	1F-VD0 <input type="checkbox"/> -01 1F-VD0 <input type="checkbox"/> E-01 <input type="checkbox"/> Not provide 1F-VD0 <input type="checkbox"/> -01 (Sink type): <input type="checkbox"/> 1set <input type="checkbox"/> 2set <input type="checkbox"/> 3set <input type="checkbox"/> 4set 1F-VD0 <input type="checkbox"/> E-01 (Source type): <input type="checkbox"/> 1set <input type="checkbox"/> 2set <input type="checkbox"/> 3set <input type="checkbox"/> 4set	
	Hand input cable	1F-HC35C-01 <input type="checkbox"/> Not provided <input type="checkbox"/> Provided	
	Hand output cable	1F-GR60S-01 <input type="checkbox"/> Not provided <input type="checkbox"/> Provided	
	Hand curl tube	1E-ST0408C-300 <input type="checkbox"/> Not provided <input type="checkbox"/> Provided	
External Wiring/Piping box	1F-UT-BOX <input type="checkbox"/> Not provided <input type="checkbox"/> Provided		
Internal Wiring/Piping for hand	1F-HS304S-01 <input type="checkbox"/> Not provided <input type="checkbox"/> Provided		
Controller	Simple teaching pendant	R32TB- <input type="checkbox"/> <input type="checkbox"/> R33TB- <input type="checkbox"/> <input type="checkbox"/> <input type="checkbox"/> Not provided R32TB (CR750 controller): <input type="checkbox"/> 7m <input type="checkbox"/> 15m R33TB (CR751 controller): <input type="checkbox"/> 7m <input type="checkbox"/> 15m	
	Highly efficient teaching pendant	R56TB- <input type="checkbox"/> <input type="checkbox"/> R57TB- <input type="checkbox"/> <input type="checkbox"/> <input type="checkbox"/> Not provided R56TB (CR750 controller): <input type="checkbox"/> 7m <input type="checkbox"/> 15m R57TB (CR751 controller): <input type="checkbox"/> 7m <input type="checkbox"/> 15m	
	Parallel I/O interface	2D-TZ368/ 2D-TZ378 <input type="checkbox"/> Not provided 2D-TZ368(Sink type)/ <input type="checkbox"/> -1pc. <input type="checkbox"/> -2pc. 2D-TZ378(Source type)/ <input type="checkbox"/> -1pc. <input type="checkbox"/> -2pc.	
	External I/O cable (For parallel I/O interface)	2D-CBL <input type="checkbox"/> <input type="checkbox"/> (2D-TZ368/TZ378) <input type="checkbox"/> Not provided <input type="checkbox"/> 5m-( )pc. <input type="checkbox"/> 15m-( )pc.	
	Parallel I/O unit	2A-RZ361/ 2A-RZ371 <input type="checkbox"/> Not provided <input type="checkbox"/> 2A-RZ361(Sink type)/( ) unit <input type="checkbox"/> 2A-RZ371(Source type)/( ) unit	
	External I/O cable (For Parallel I/O unit)	2A-CBL <input type="checkbox"/> <input type="checkbox"/> (2A-RZ361/RZ371) <input type="checkbox"/> Not provided <input type="checkbox"/> 5m-( )pc. <input type="checkbox"/> 15m-( )pc.	
	CC-Link interface	2D-TZ576 <input type="checkbox"/> Not provided <input type="checkbox"/> Provided	
	RT ToolBox2	3D-11C-WINE <input type="checkbox"/> Not provided <input type="checkbox"/> Windows XP/Vista/7/8/8.1 English CD-ROM	
	RT ToolBox2 mini	3D-12C-WINE <input type="checkbox"/> Not provided <input type="checkbox"/> Windows XP/Vista/7/8/8.1 English CD-ROM	
	Instructions manual	5F-FA01-PE01 <input type="checkbox"/> Not provided <input type="checkbox"/> Provided ( ) sets	

## ■ Maintenance parts (Consumable parts)

Maintenance parts	<input type="checkbox"/> Backup batteries ER6 ( ) pcs. <input type="checkbox"/> Backup batteries Q6BAT ( ) pcs. <input type="checkbox"/> Grease ( ) cans
-------------------	--

## ■ Robot selection check list

Work description	<input type="checkbox"/> Material handling <input type="checkbox"/> Assembly <input type="checkbox"/> Machining L/UL <input type="checkbox"/> Sealing <input type="checkbox"/> Testing and inspection <input type="checkbox"/> Other ( )		
Workpiece mass ( ) g	Hand mass ( ) g	Atmosphere	<input type="checkbox"/> General environment <input type="checkbox"/> Clean <input type="checkbox"/> Other ( )
Remarks			



Product Service

# EC-Statement of Compliance

No. E6 14 07 25554 052

**Holder of Certificate:** Mitsubishi Electric CorporationTokyo BILD., 2-7-3 Marunouchi,  
Chiyoda-ku  
Tokyo  
100-8310 JAPAN**Name of Object:** Industrial, Scientific and Medical  
equipment  
Industrial Robot**Model(s):** F series  
(See Attachment for Nomenclature)**Description of Object:** Rated Voltage: 230 VAC  
Rated Power: 1.7 kW  
Protection Class: I**Tested according to:** EN 61000-6-4/A1:2011  
EN 61000-6-2:2005

This EC-Statement of Compliance is issued according to the Directive 2004/108/EC relating to electromagnetic compatibility. It confirms that the listed apparatus complies with such aspects of the essential requirements of the EMC directive as specified by the manufacturer or his authorized representative in the European Community and applies only to the sample and its technical documentation submitted to TÜV SÜD Product Service GmbH for testing and certification. See also notes overleaf.

**Technical report no.:** 73549408**Date,** 2014-07-30  
( Johann Roidt )

TÜV SÜD Product Service GmbH is Notified Body to the Directive 2004/108/EC of the European Parliament and of the council with the identification number 0123.

Page 1 of 8

## Attachment

Statement No.

**E6 14 07 25554 052**



Product Service

### Nomenclature

A: Model name of **F** series Robot description is shown as follows.

A1:RH-3FH,RH6FH,RH-2FH series 1.7kW

**RH-x FH xx xx x - x x x-Sxx**

(1) (2) (3) (4) (5) (6) (7) (8) (9) (10) (11)

(1)**RH**: Horizontal Robot

(2) Maximum Payload specification:

**3** : 3kg **2** : 2kg

**6** : 6kg

(3) **F** : **F** series robot

(4)**H** :4 joints

(5) Robot Arm length(No1 and No2 arm) specification:

**35** : 350 mm arm **15** : 150 mm arm

**45** : 450 mm arm

**55** : 550 mm arm

(6) Z stroke length specification:

**12** : 120 mm arm **25** : 250 mm arm

**15** : 150 mm arm

**20** : 200 mm arm

**34** : 340 mm arm

(7) Dimension and Ambient specification:

**M** : Oil mist model(IP65)

**C** : Clean room model(ISO5)

[none]: Basic model(IP54)

(8) Type of Robot controller cabinet

[none] :CR750 controller

1 :CR751 controller

(9)Robot controller type:

**D** :Stand alone type

**Q** :iQ platform type

(10)Standard:

0: normal type

1:CE marking model

2:CE marking and UL model

(11)Optional Specification:

1 :normal type

SM :added cabinet box over Robot controller for oil mist resist

Sxx :Mechanical option

## Attachment

Statement No.

**E6 14 07 25554 052**



Product Service

A2:RH-12FH,RH-20FHseries 1.7kW

**RH-x FH xx xx x - x x x-Sxx**

(1) (2) (3) (4) (5) (6) (7) (8) (9) (10) (11)

(1) **RH**: Horizontal Robot

(2) Maximum Payload specification:

**12** : 12kg

**20** : 20kg

(3) **F** : **F** series robot

(4) **H** :4 joints

(5) Robot Arm length(No1 and No2 arm) specification:

**55** : 550 mm arm

**70** : 700 mm arm

**85** : 850 mm arm

**100** : 1000 mm arm

(6) Z stroke length specification:

**35** : 350 mm arm

**45** : 450 mm arm

(7) Dimension and Ambient specification:

**M** : Oil mist model(IP65)

**C** : Clean room model(ISO3)

**N** : Special spec. For EU(IP54)

[none]: Basic model(IP20)

(8) Type of Robot controller cabinet

[none] :CR750 controller

1 :CR751 controller

(9)Robot controller type:

**D** :Stand alone type

**Q** :iQ platform type

(10)Standard:

0: normal type

1:CE marking model

2:CE marking and UL model

(11)Optional Specification:

1 :normal type

SM :added cabinet box over Robot controller for oil mist resist

Sxx :Mechanical option

Attachment

Statement No.

**E6 14 07 25554 052**



Product Service

A3:RV-2Fseries 1.7kW

**RV-x F x - x x x-Sxx**

(1) (2) (3) (4) (5) (6) (7) (8)

(1)**RV**: Vertical Robot

(2) Maximum Payload specification:

**2** : 2kg

(3) **F** : **F** series robot

(4)Robot Joint type

**B** :All axes have brake units.

[none] :J4 axis doesn't have brake unit.

(5) Type of Robot controller cabinet

[none] :CR750 controller

**1** :CR751 controller

(6)Robot controller type:

**D** :Stand alone type

**Q** :iQ platform type

(7)Standard:

**0**: normal type

**1**:CE marking model

**2**:CE marking and UL model

(8)Optional Specification:

**1** :normal type

**SM** :added cabinet box over Robot controller for oil mist resist

**Sxx** :Mechanical option

## Attachment

Statement No.

# E6 14 07 25554 052



Product Service

A4:RV-4F,7Fseries 1.7kW

**RV-x F x x x - x x x-Sxx**

(1) (2) (3) (4) (5) (6) (7) (8) (9) (10)

(1)**RV**: Vertical Robot

(2) Maximum Payload specification:

**4** : 4kg

**7** : 7kg

(3) **F** : **F** series robot

(4) Robot axes:

**J** : 5 axes model

[none] : normal model

(5) Robot arm length:

**L** : Long arm model

[none]: normal model

(6) Dimension and Ambient specification:

**M** : Oil mist model(IP67)

**C** : Clean room model(ISO3)

[none] : Basic model(IP40)

(7) Type of Robot controller cabinet

[none] :CR750 controller

1 :CR751 controller

(8)Robot controller type:

**D** :Stand alone type

**Q** :iQ platform type

(9)Standard:

0: normal type

1:CE marking model

2:CE marking and UL model

(10)Optional Specification:

1 :normal type

SM :added cabinet box over Robot controller for oil mist resist

SH :Internal tube and wires are extended to J6 axis.

Sxx :Mechanical option

## Attachment

Statement No.

# E6 14 07 25554 052



Product Service

A5:RV-13F,20F,7FLLseries 1.7kW

**RV-x F x x - x x x-Sxx**

(1) (2) (3) (4) (5) (6) (7) (8) (9)

(1)RV: Vertical Robot

(2) Maximum Payload specification:

**13** : 13kg **20** : 20kg

**7** : 7kg

(3) **F** : **F** series robot

(4) Robot arm length:

**L** : Long arm model

**LL** : Long reach(1503mm) model (for onlyRV-7FLL series)

[none]: normal model

(5) Dimension and Ambient specification:

**M** : Oil mist model(IP67)

**C** : Clean room model(ISO3)

[none] : Basic model(IP40)

(6) Type of Robot controller cabinet

[none] :CR750 controller

1 :CR751 controller

(7)Robot controller type:

**D** :Stand alone type

**Q** :iQ platform type

(8)Standard:

0: normal type

1:CE marking model

2:CE marking and UL model

(9)Optional Specification:

1 :normal type

SM :added cabinet box over Robot controller for oil mist resist

SH :Internal tube and wires are extended to J6 axis.

Sxx :Mechanical option

## Attachment

Statement No.

**E6 14 07 25554 052**



Product Service

A6:RH-1FHR,RH-3FHR series 1.7kW

**RH-x F HR xx xx x - x x x-Sxx**

(1) (2) (3) (4) (5) (6) (7) (8) (9) (10) (11)

(1)**RH**: Horizontal Robot

(2) Maximum Payload specification:

**1** : 1kg

**3** : 3kg

(3) **F** : **F** series robot

(4)**HR** : 4 joints ,reverse mount model

(5) Robot Arm length(No1 and No2 arm) specification:

**35** : 350 mm arm **75** : 750 mm arm

**55** : 550 mm arm

(6) Z stroke length specification:

**12** : 120 mm arm

**15** : 150 mm arm

(7) Dimension and Ambient specification:

**W** : Water proof model

**M** : Oil mist model

**C** : Clean room model(ISO5)

[none] : Basic model(IP54)

(8) Type of Robot controller cabinet

[none] :CR750 controller

1 :CR751 controller

(9)Robot controller type:

**D** :Stand alone type

**Q** :iQ platform type

(10)Standard:

0: normal type

1:CE marking model

2:CE marking and UL model

(11)Optional Specification:

1 :normal type

SM :added cabinet box over Robot controller for oil mist resist

Sxx :Mechanical option



Attachment

Statement No.

**E6 14 07 25554 052**



Product Service

B: Model name of **F** series Robot controller description is shown as follows.

**CR750- xx x x x - x- x-Sxx**  
 (1) (2) (3) (4) (5) (6) (7) (8)

(1)**CR750**: CR750 controller  
**CR751**: CR751 controller

(2) Maximum Payload specification:

- 01** : 1kg
- 03** : 3kg
- 06** : 6kg
- 12** : 12kg
- 20** : 20kg
- 02** : 2kg
- 04** : 4kg
- 07** : 7kg
- 13** : 13kg

(3) Robot type

- H** : Horizontal robot
- HR** : Horizontal robot(reverse mount)
- V** : Vertical robot
- VJ** : 5 axes Vertical robot
- VL** : for only RV-7FLL series

(4)Robot controller type

- D** :stand alone
- Q** :iQ platform type

(5)Standard

- 1 :CE marking model
- 2 :CE marking and UL model

(6)Operation Panel

- [none] :No panel type
- 1 :Panel type

(7)Power input connector type

- [none] :normal type
- P2 :Added cable with a connector and a terminal
- P3 :Added cable with a connector and a terminal block

(8)Optional Specification

- [none] :normal
- SM :Added Cabinet box over robot controller for oil mist resist
- Sxx :mechanical option



**EC DECLARATION OF CONFORMITY**  
 (According to EMC Directive)  
**EC DECLARATION OF INCORPORATION**  
 (According to Machinery Directive)

We,

Manufacturer: MITSUBISHI ELECTRIC Corporation Nagoya Works  
 Address 1-14 Yada-Minami 5-Chome Higashi-Ku, Nagoya 461-8670, Japan

(Place of Declare):

Declare under our sole responsibility that the Product

Description: Industrial Robot  
 Type of Model: F series  
 Notice: Details of Serial number are as per attached Nomenclature.  
 Restrictive use: For industrial environment only

Conforms with the essential requirements of the **EMC Directive 2004/108/EC** and the **Machinery Directive 2006/42/EC**, based on the following specifications applied:

EU Harmonized Standards		Non-harmonized Standard
EMC(2004/108/EC)	EN 61000-6-4:2007+A1:2011 EN61000-6-2:2005	N/A
Machinery(2006/42/EC)	Type A: Fundamental safety standards EN ISO12100-1:2003 EN ISO12100-2:2003 EN 1050:1997 Type B: Group safety standards B1: Safety aspects EN60204-1:2006, EN294:1992, EN349:1993 IEC61326-3-1:2008 ISO13849-1:2006 (Category 3 and Performance level "d") Type C: Machine Safety standard ISO10218-1:2011	N/A

and therefore complies with the essential requirements and provisions of the EMC Directive and the Machinery Directive.

**< Partly completed Machinery >**

This product meets the specification and/or the performance by correct installing.  
 So it must not be used until being installed into the final machinery of the customer.

Issue Date (Date of Declaration): 29. 7. 2018

The identity and signature of the person empowered to bind the manufacturer or his authorized representative.

Tomoyuki Kobayashi  
 (signature)

[Tomoyuki Kobayashi]

Senior Manager  
 Robot Manufacturing Department  
 MITSUBISHI ELECTRIC Corporation Nagoya Works

Authorized representative in Europe  
 (The person authorized compiles the relevant Technical documentation)

Hartmut Putz  
 (signature)

[Hartmut Putz]

FA Product Marketing Director FA Group  
 Gother St. 8 40880 Ratingen, Germany  
 MITSUBISHI Electric Europe B.V Germany

# **RH - xFH xxxx x - xxx - Sxx**

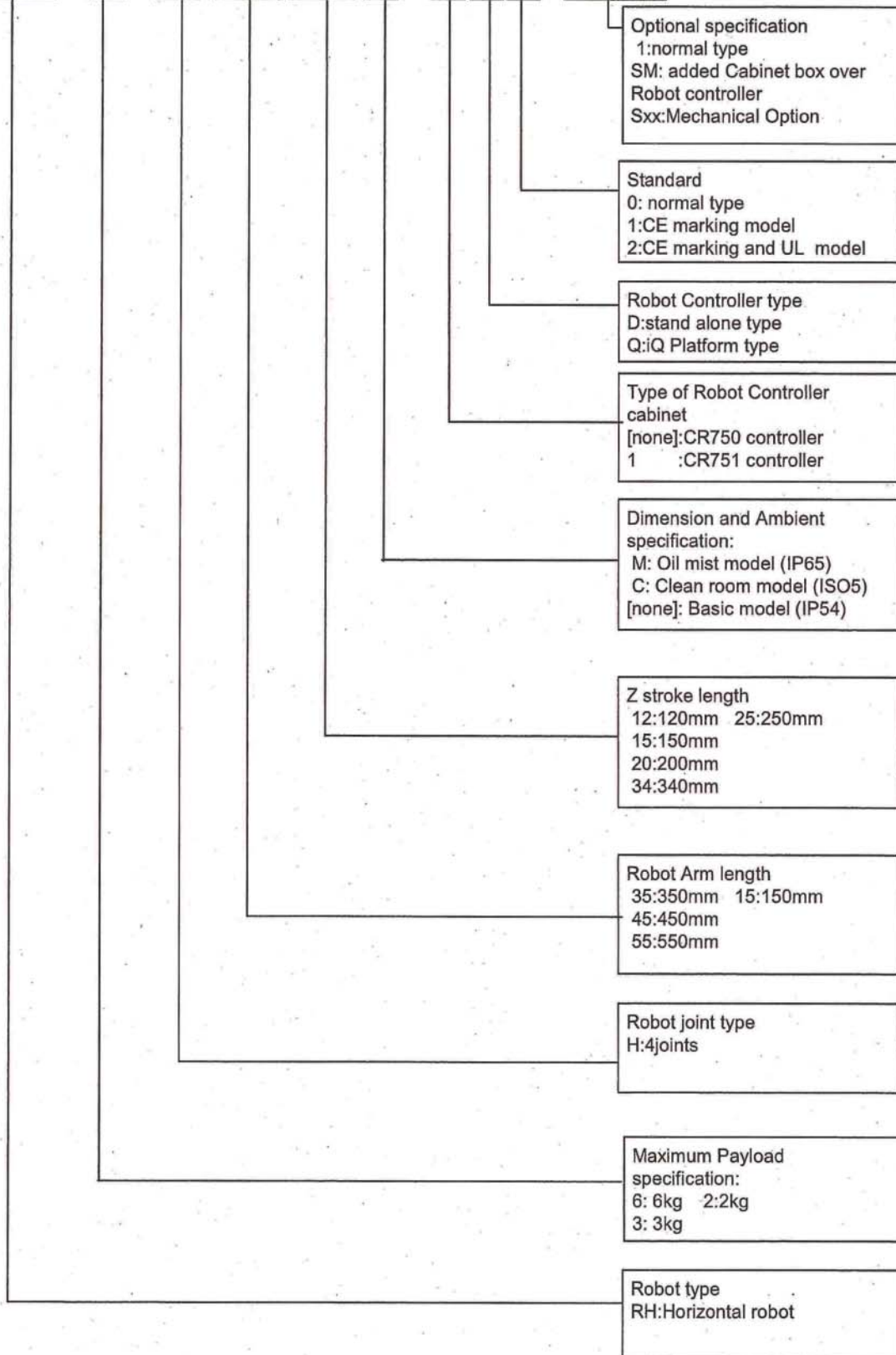

Fig.1-1 Nomenclature of F series robot of RH-6FH,3FH ,2FH series.

# RH - xFH xx xx x - xxx - Sxx

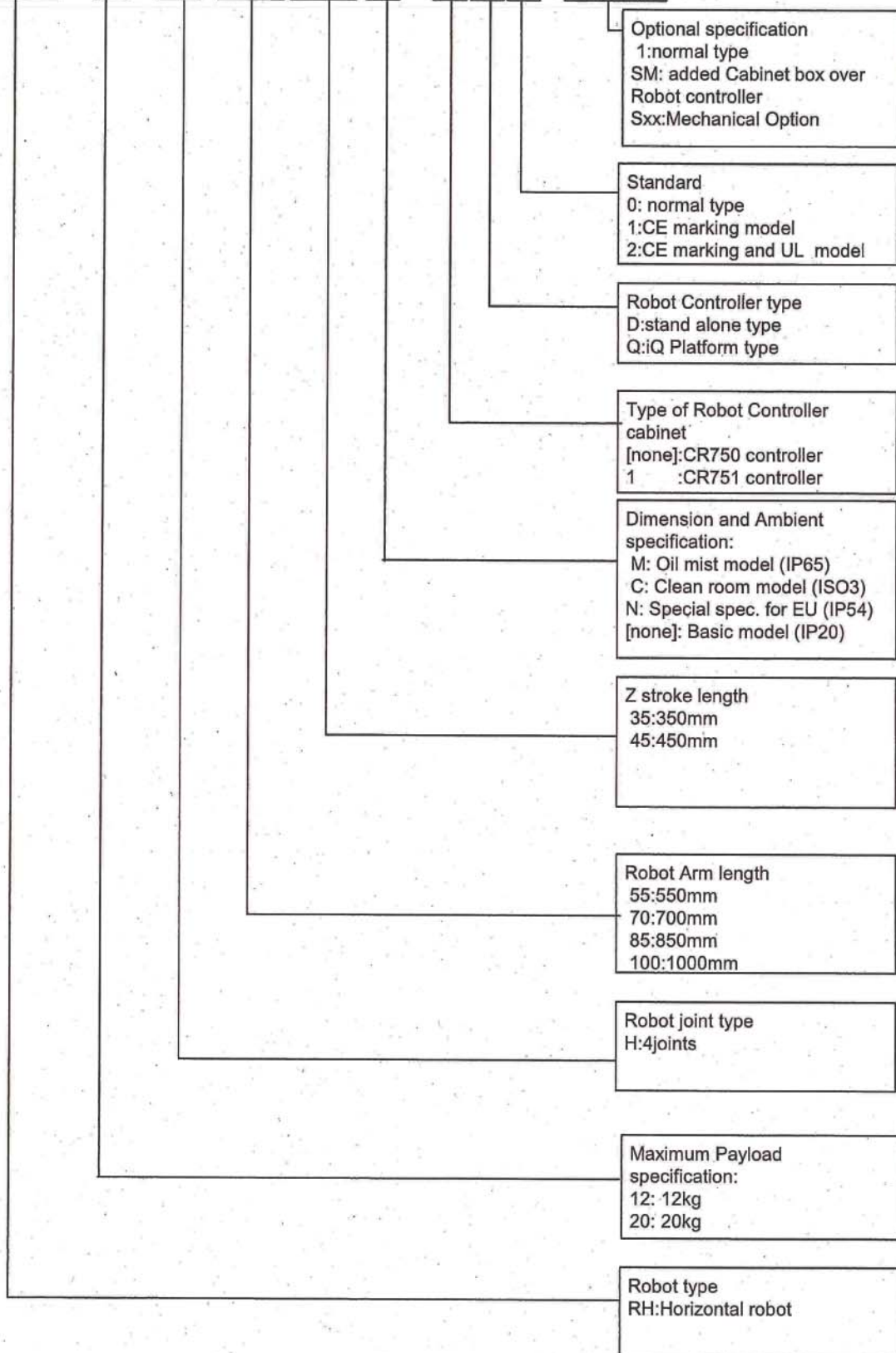

Fig.1-2 Nomenclature of F series robot of RH-12FH,20FH series

# **RV-xF x-xxx-Sxx**

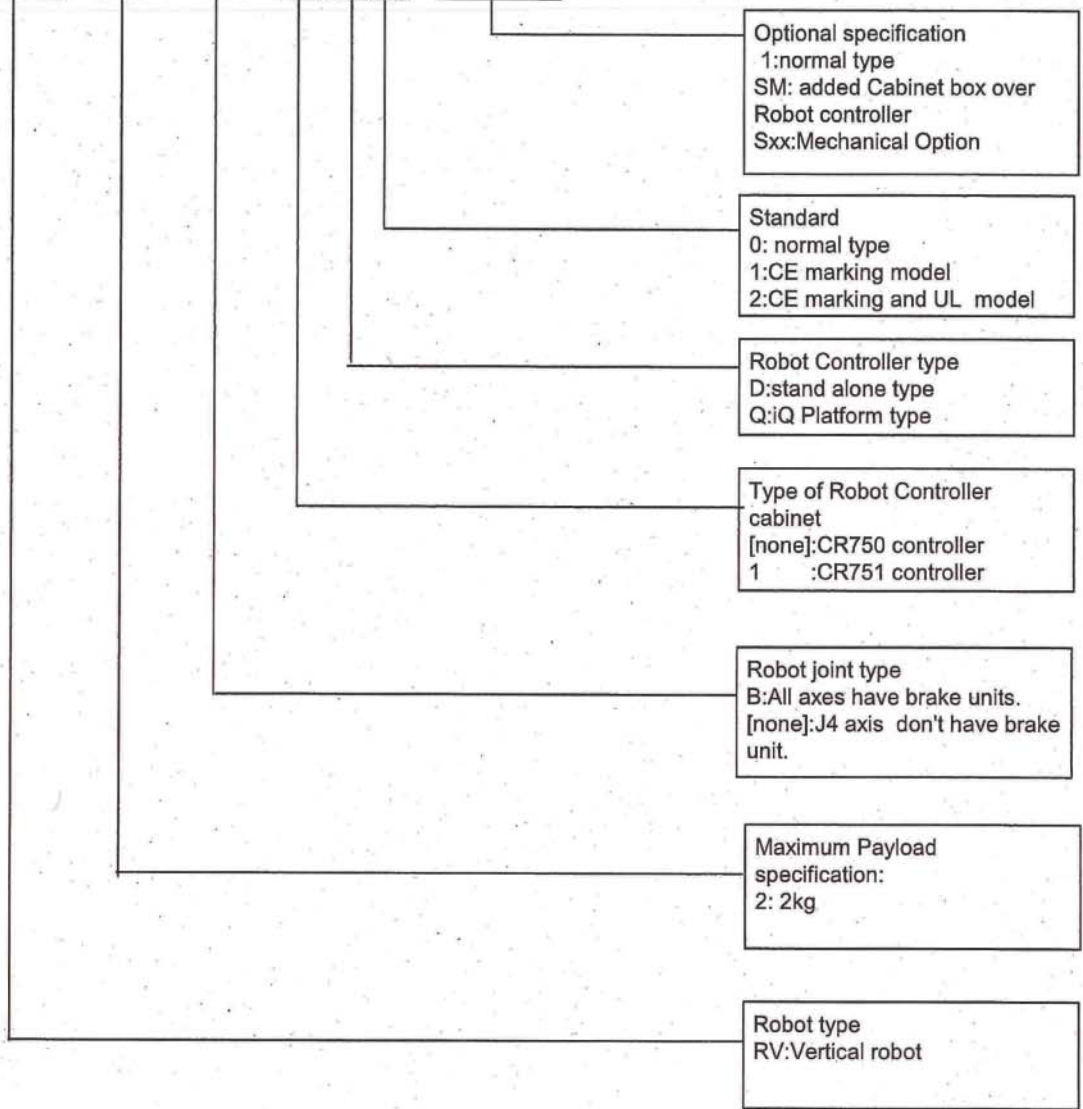

Fig.1-3 Nomenclature of F series robot of RV-2F series

# RV - xFxxx-xxx-Sxx

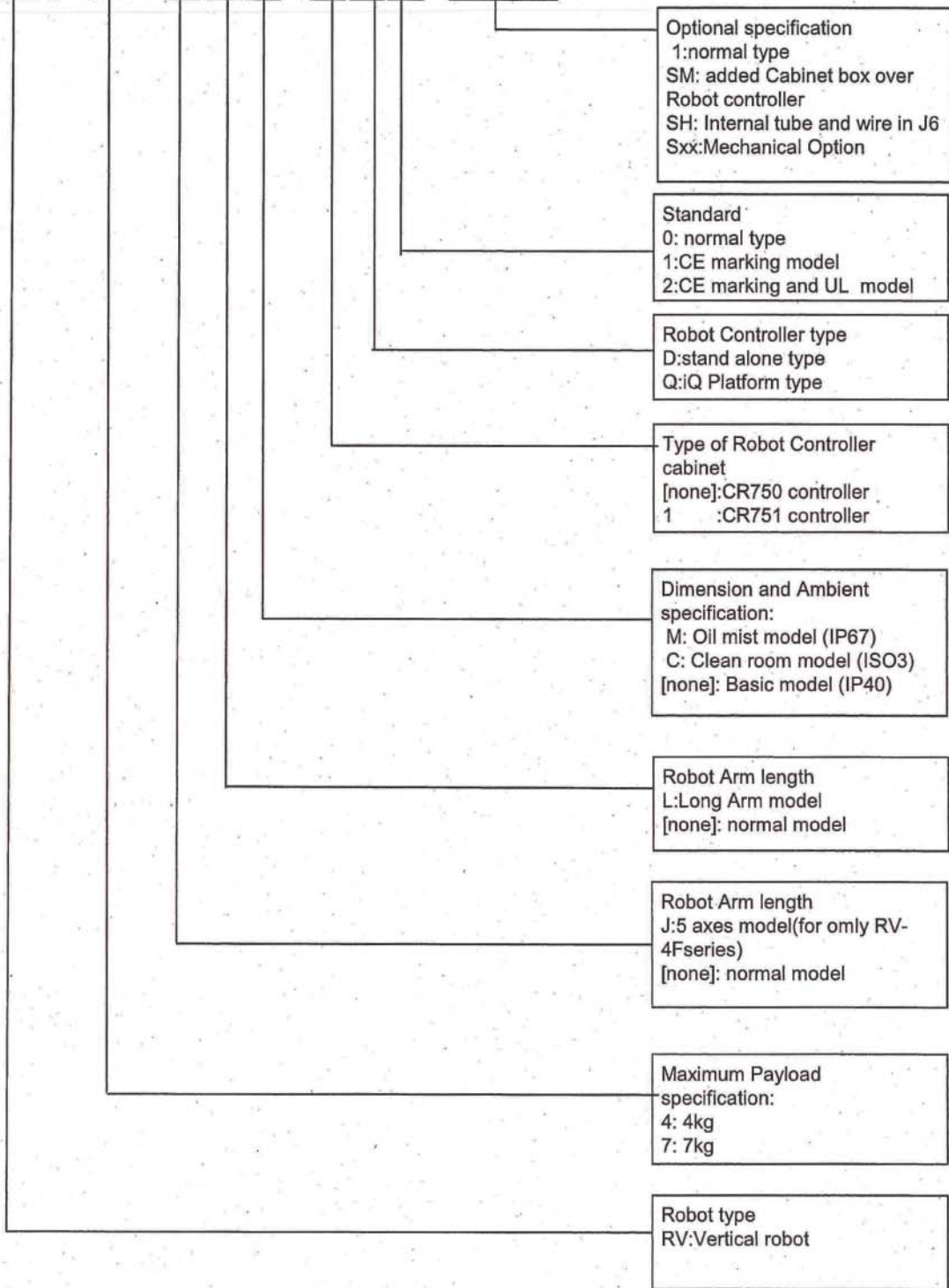

Fig.1-4 Nomenclature of F series robot of RV-4F,7F series

# RV-xF x x-xxx-Sxx

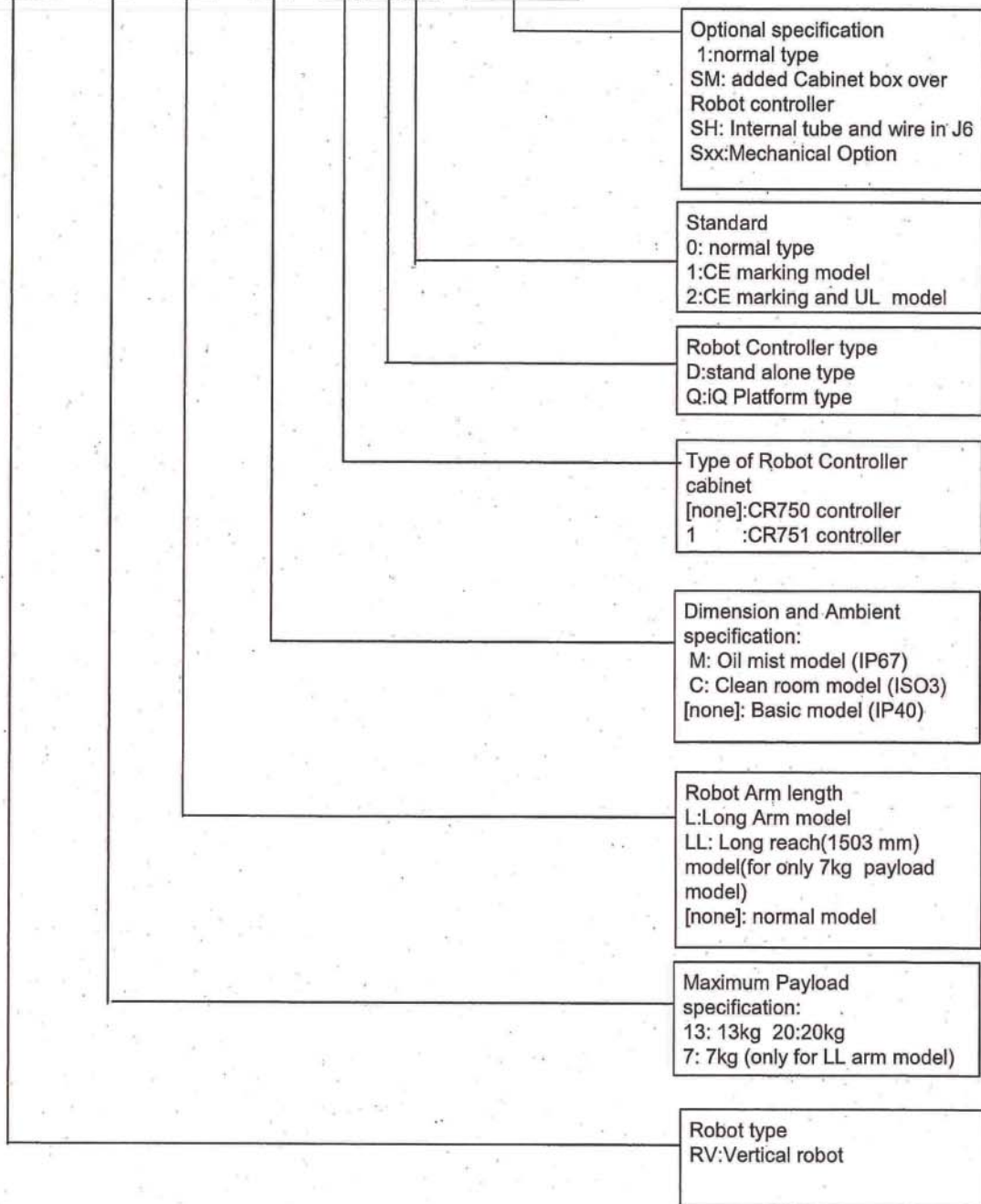

Fig.1-5 Nomenclature of F series robot of RV-13F,20F,7FLL series

# RH-xFHRxx xx x - xxx- Sxx

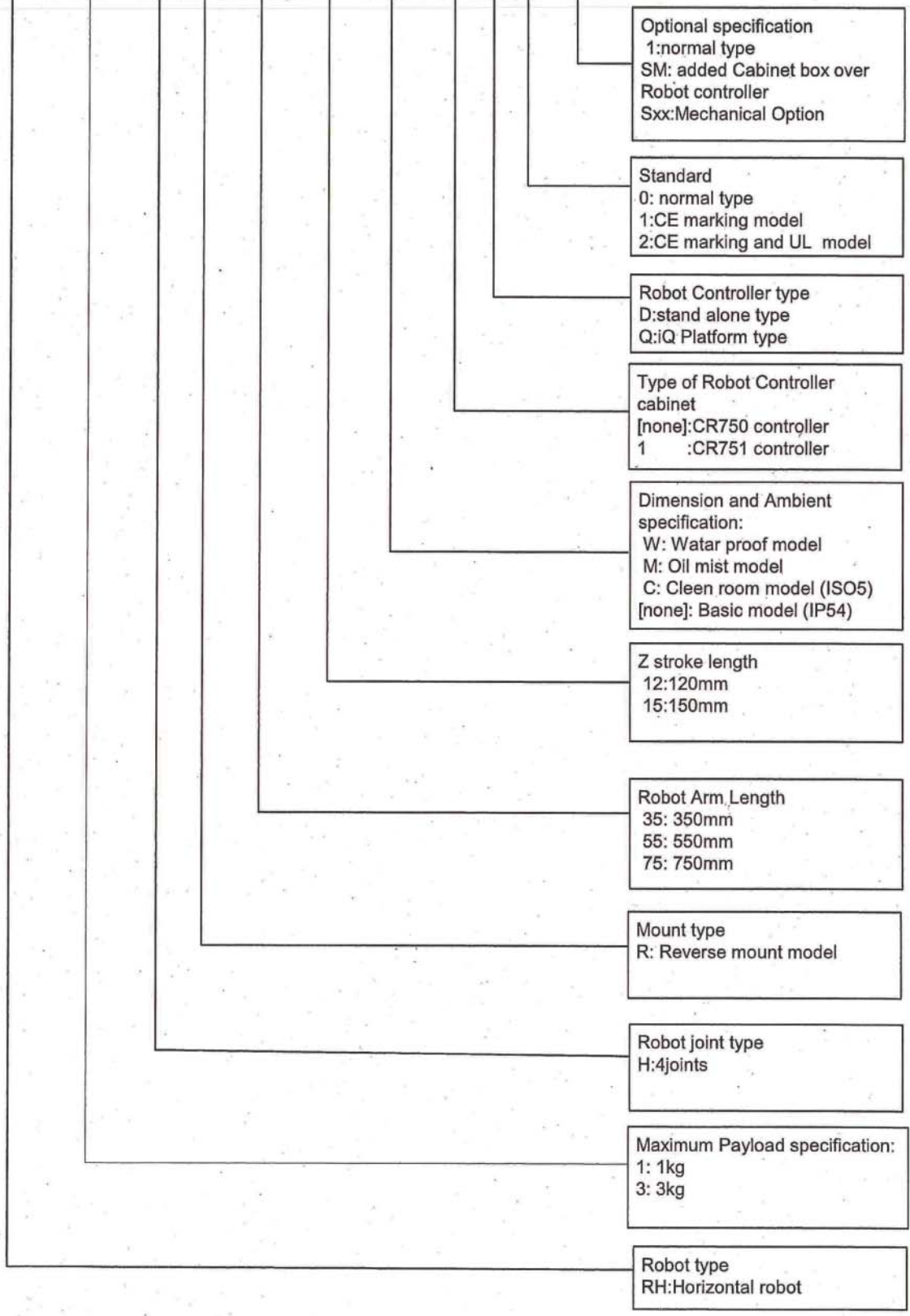

Fig.1-6 Nomenclature of F series robot of RH-1FHR, RH-3FHR series



# CR750 - xx x x x - x-x - Sxx

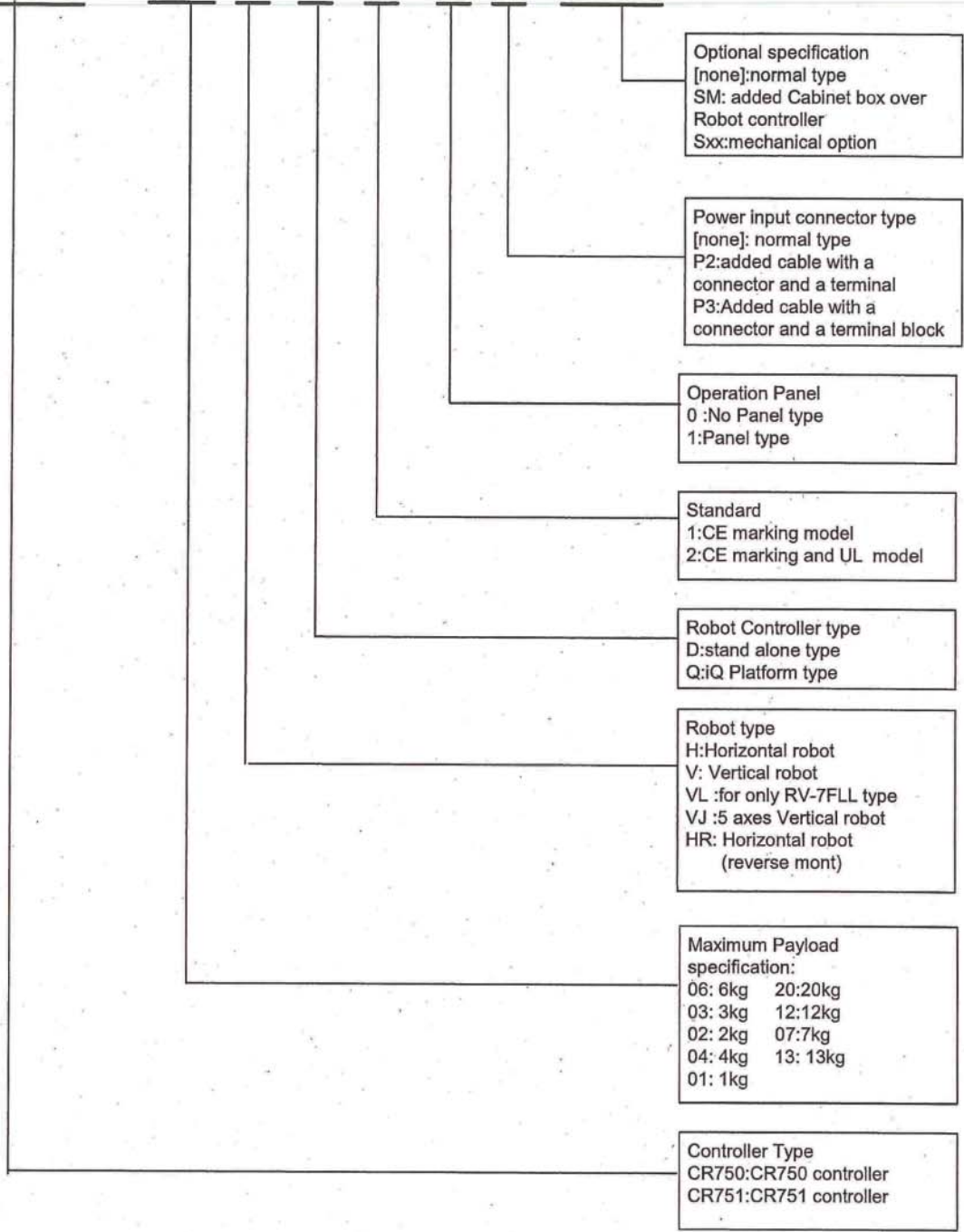

Fig.2-1 Nomenclature of F series robot controller

■ Details of serial number

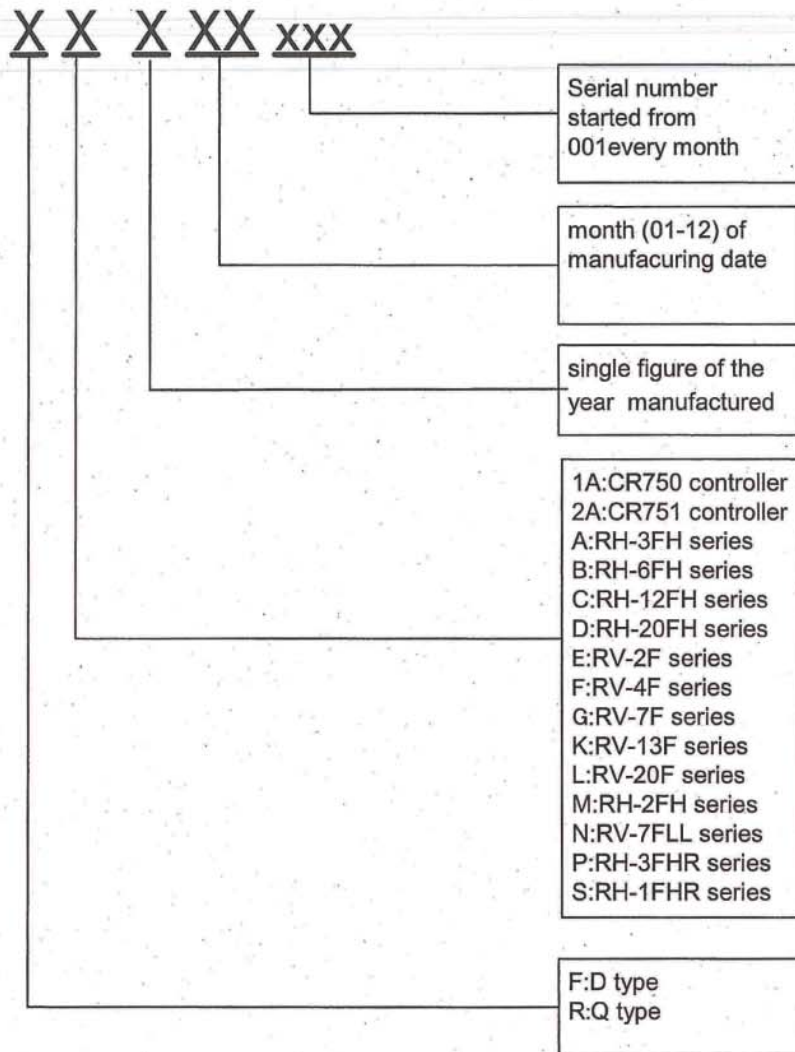

Fig.3.1 Nomenclature of serial number about F series Robot and robot controller

Revision history

Date	Specifications No.	Details of revisions	Rev.
April 16,2012		First print	*
May 25, 2012		Q type are added.	A
Oct 1, 2012	Fig.1-2,1-3,1-4 added	RH-12/20FH-D series,RV-2F-D series,RV-4F/7F-D series are added.	B
Nov 1,2012	P1 P3-P7	Form is changed. RH-12/20FH-Q series,RV-2F-Q series,RV-4F/7F-Q series are added "Details of serial No." is added	C
Apr 15, 2013	P2,P6,P7,P8	RH-2FH series,RV-13F,20FH,7FLL series are added	D
Mar 12,2014	P1 P5	Standards are updated. "J"option added (RV-4FJseries added)	E
Apr 24, 2014	P1	Standards are updated.	F
Jul 9 2014	P7	RH-3FHR series.and RH-1FHR series are added.	

## 사용자안내문 User's Guide

기종별 Type of Equipment	사용자안내문 User's Guide
<p>A 급 기기 (업무용 방송통신기자재)</p> <p>Class A Equipment (Industrial Broadcasting &amp; Communication Equipment)</p>	<p>이 기기는 업무용(A 급) 전자파적합기기로서 판매자 또는 사용자는 이 점을 주의하시기 바라며, 가정외의 지역에서 사용하는 것을 목적으로 합니다.</p> <p>This equipment is Industrial (Class A) electromagnetic wave suitability equipment and seller or user should take notice of it, and this equipment is to be used in the places except for home.</p>
<p>B 급 기기 (가정용 방송통신기자재)</p> <p>Class B Equipment (For Home Use Broadcasting &amp; Communication Equipment)</p>	<p>이 기기는 가정용(B 급) 전자파적합기기로서 주로 가정에서 사용하는 것을 목적으로 하며, 모든 지역에서 사용할 수 있습니다.</p> <p>This equipment is home use (Class B) electromagnetic wave suitability equipment and to be used mainly at home and it can be used in all areas.</p>





# **MITSUBISHI ELECTRIC CORPORATION**

HEAD OFFICE: TOKYO BUILDING, 2-7-3, MARUNOUCHI, CHIYODA-KU, TOKYO 100-8310, JAPAN  
NAGOYA WORKS: 5-1-14, YADA-MINAMI, HIGASHI-KU NAGOYA 461-8670, JAPAN

Authorised representative:

MITSUBISHI ELECTRIC EUROPE B.V. GERMANY  
Gothaer Str. 8, 40880 Ratingen / P.O. Box 1548, 40835 Ratingen, Germany